



---

# Customer information packet

## AEM3683-4

1HP, 1755RPM, 3PH, 60HZ, 182, 0620M, TENV, F1, N

Class - None

Division - Not Applicable

## Specifications

Enclosure	TENV
Frame	182
Frame Material	Iron
Frequency	60.00 Hz
Haz Area Class and Group	None
Haz Area Division	Not Applicable
Motor Letter Type	Three Phase
Output @ Frequency	1.000 HP @ 60 HZ
Phase	3
Synchronous Speed @ Frequency	1800 RPM @ 60 HZ
Voltage @ Frequency	460.0 V @ 60 HZ
Agency Approvals	UR CSA
Ambient Temperature	65 °C
Auxillary Box	No Auxillary Box
Auxillary Box Lead Termination	None
Base Indicator	Rigid
Bearing Grease Type	Polyrex EM (-20F +300F)
Blower	None
Current @ Voltage	1.600 A @ 460.0 V
Design Code	B
Drip Cover	No Drip Cover
Duty Rating	CONT
Efficiency @ 100% Load	85.5 %
Electrically Isolated Bearing	Not Electrically Isolated
Feedback Device	NO FEEDBACK
Front Face Code	Standard
Front Shaft Indicator	None
Heater Indicator	No Heater
High Voltage Full Load Amps	1.6 a
Insulation Class	F
Inverter Code	Inverter Ready

## Part detail

Revision	H
Type	AC
Mech. spec.	06H063
Base	
Status	PRD/A
Elec. spec.	06WGX713
Layout	06LYH063
Eff. date	08-20-2024
CD Diagram	CD0006
Poles	04
Leads	3#16
Proprietary	False
Created date	02-23-2015

<b>KVA Code</b>	N
<b>Lifting Lugs</b>	Standard Lifting Lugs
<b>Locked Bearing Indicator</b>	No Locked Bearing
<b>Motor Lead Exit</b>	Ko Box
<b>Motor Lead Quantity/Wire Size</b>	3 @ 16 AWG
<b>Motor Lead Termination</b>	Flying Leads
<b>Motor Standards</b>	NEMA
<b>Motor Type</b>	0620M
<b>Mounting Arrangement</b>	F1
<b>Number of Poles</b>	4
<b>Overall Length</b>	13.18 IN
<b>Power Factor</b>	67
<b>Product Family</b>	Automotive (Not For DC)
<b>Pulley End Bearing Type</b>	Ball
<b>Pulley Face Code</b>	Standard
<b>Pulley Shaft Indicator</b>	Standard
<b>Rodent Screen</b>	None
<b>Service Factor</b>	1.00
<b>Shaft Diameter</b>	0.875 IN
<b>Shaft Extension Location</b>	Pulley End
<b>Shaft Ground Indicator</b>	No Shaft Grounding
<b>Shaft Rotation</b>	Reversible
<b>Shaft Slinger Indicator</b>	No Slinger
<b>Speed</b>	1755 rpm
<b>Speed Code</b>	Single Speed
<b>Starting Method</b>	Direct on line
<b>Thermal Device - Bearing</b>	None
<b>Thermal Device - Winding</b>	None
<b>Vibration Sensor Indicator</b>	No Vibration Sensor
<b>Winding Thermal 1</b>	None
<b>Winding Thermal 2</b>	None

**Nameplate**

<b>NP1404</b>									
<b>CAT.NO.</b>	AEM3683-4								
<b>SPEC.</b>	06H063X713G1								
<b>VOLTS</b>	460								
<b>AMP</b>	1.6								
<b>RPM</b>	1755		<b>HP</b>	1					
<b>FRAME</b>	182		<b>HZ</b>	60		<b>PH</b>	3		
<b>SER.F.</b>	1.00		<b>CODE</b>	N	<b>DES</b>	B	<b>CL</b>	F	
<b>NEMA-NOM-EFF</b>	85.5		<b>PF</b>	67					
<b>G.MIN.EFF</b>	82.5		<b>CC</b>						
<b>RATING</b>	65C AMB-CONT								
<b>LUBRICATION</b>	POLYREX EM								
<b>DE</b>	6206		<b>ODE</b>	6205					
<b>ENCL</b>	TENV		<b>SER. #</b>						

## Parts list

Part number	Description	Quantity
SA294206	SA 06H063X713G1	1.000 ea
RA280288	RA 06H063X713G1	1.000 ea
HW3201A05	3/8-16 EYEBOLT	1.000 ea
06CB1000A02G	CONDUIT BOX, MACH GRAY	1.000 ea
06GS1007	GASKET, CONDUIT BOX	1.000 ea
51XW2520A12	SCREW, HEX SER SLT HD, ZN, 1/4-20 X .75	2.000 ea
11XW1032G06	10-32 X .38, TAPTITE II, HEX WSHR SLTD U	1.000 ea
HW3001B01	BRASS CUP WASHER, FOR #10 SCREW	1.000 ea
36EP1101A50G	FR ENDPLATE MACH, TENN	1.000 ea
HW4500A19	1/4-28X1/4 SLOTTED PLUG F/S	2.000 ea
HA4054	SHORT T-DRAIN FITTING, .125" N.P.T.	1.000 ea
HW5100A05	WVY WSHR F/205 & 304 BRGS	1.000 ea
36EP1100A21G	SPL PU ENDPLATE MACH'D FOR SLINGER (GRAY	1.000 ea
HW4500A19	1/4-28X1/4 SLOTTED PLUG F/S	2.000 ea
HW4500A20	1/8NPT SL PIPE PLUG	1.000 ea
HA3101A34	THRUBOLT- 1/4-20 X 10.375	4.000 ea
XY2520A12	1/4-20 HEX NUT, DIRECTIONAL SERRATIONS	4.000 ea
06CB1500A01G	CONDUIT BOX LID, MACH GRAY	1.000 ea
06GS1003	GASKET, KOBX LID, 1/8" THICK BLACK NEOPR	1.000 ea
10XN2520A12	1/4-20 X 3/4 HEX HEAD CAP	2.000 ea
HW1001A25	LOCKWASHER 1/4, ZINC PLT .493 OD, .255 I	2.000 ea
HA1005A22	SLINGER, OD 2.00, ID 1.14, 206 BRG, GM	1.000 ea
MJ5001A27	32220KN GRAY SEALER *MIN BUY 4 QTS=1GAL	0.001 qt
HW2501D13	KEY, 3/16 SQ X 1.375	1.000 ea
HA7000A01	KEY RETAINER 7/8" DIA SHAFT	1.000 ea
85XU0407S04	4X1/4 U DRIVE PIN STAINLESS	2.000 ea
LB1624	COMBINED WARNING LABEL, ISO/ANSI PICTOGR	1.000 ea
MJ5001A14	DYNAPRO SEALANT, CP MTR VC#2508050 (603	0.001 ea
WD1000B03	BURNDY YAV14 TERML (1M/PK)	3.000 ea
MJ1000A02	GREASE, POLYREX EM EXXON	0.050 lb
MG1025G02	WILKOFAS, 782.02, LIGHT GRAY	0.028 ga

LC0006	CONNECTION LABEL	1.000 ea
NP1404	SS UL CSA CC "AUTOMOTIVE"	1.000 ea
36PA1001	PKG GRP, PRINT PK1017A06	1.000 ea
MN416A01	TAG-INSTAL-MAINT no wire (2500bx)4/22	1.000 ea

**Accessories**

<b>Part number</b>	<b>Description</b>	<b>Multiplier</b>
36-3301	C FACE KIT	A8

**AC Induction Motor Performance Data**

Record # 50241

Typical performance - not guaranteed values

<b>Winding:</b> 06WGX713-R008		<b>Type:</b> 0620M		<b>Enclosure:</b> TENV	
<b>Nameplate Data</b>			<b>460 V, 60 Hz: Single Voltage Motor</b>		
<b>Rated Output (HP)</b>	1	<b>Full Load Torque</b>	3 LB-FT		
<b>Volts</b>	460	<b>Start Configuration</b>	direct on line		
<b>Full Load Amps</b>	1.6	<b>Breakdown Torque</b>	15.7 LB-FT		
<b>R.P.M.</b>	1755	<b>Pull-up Torque</b>	8.83 LB-FT		
<b>Hz</b>	60	<b>Locked-rotor Torque</b>	9.9 LB-FT		
<b>NEMA Design Code</b>	B	<b>Starting Current</b>	14.7 A		
<b>Service Factor (S.F.)</b>	1	<b>No-load Current</b>	1.12 A		
<b>NEMA Nom. Eff.</b>	85.5	<b>Line-line Res. @ 25°C</b>	10.3 Ω		
<b>Rating - Duty</b>	65C AMB-CONT	<b>Temp. Rise @ Rated Load</b>	14°C		
		<b>Locked-rotor Power Factor</b>	46.5		
		<b>Rotor inertia</b>	0.186 LB-FT <sup>2</sup>		

**Load Characteristics 460 V, 60 Hz, 1 HP**

<b>% of Rated Load</b>	<b>25</b>	<b>50</b>	<b>75</b>	<b>100</b>	<b>125</b>	<b>150</b>
<b>Power Factor</b>	30	46	58	67	73	77
<b>Efficiency</b>	71	80.9	84.7	86.2	86.9	86.3
<b>Speed</b>	1792	1783	1776	1767	1757	1747
<b>Line amperes</b>	1.18	1.3	1.45	1.64	1.87	2.14



ABB Motors and Mechanical Inc.

WINDING # 06WGX713

Typical performance - not guaranteed values.

1 HP 3 PH 60 HZ 1755 RPM 460 V 0620M

TORQUES (LB-FT): PO=15.7 PU=8.83 LR=9.9 LRA=14.7

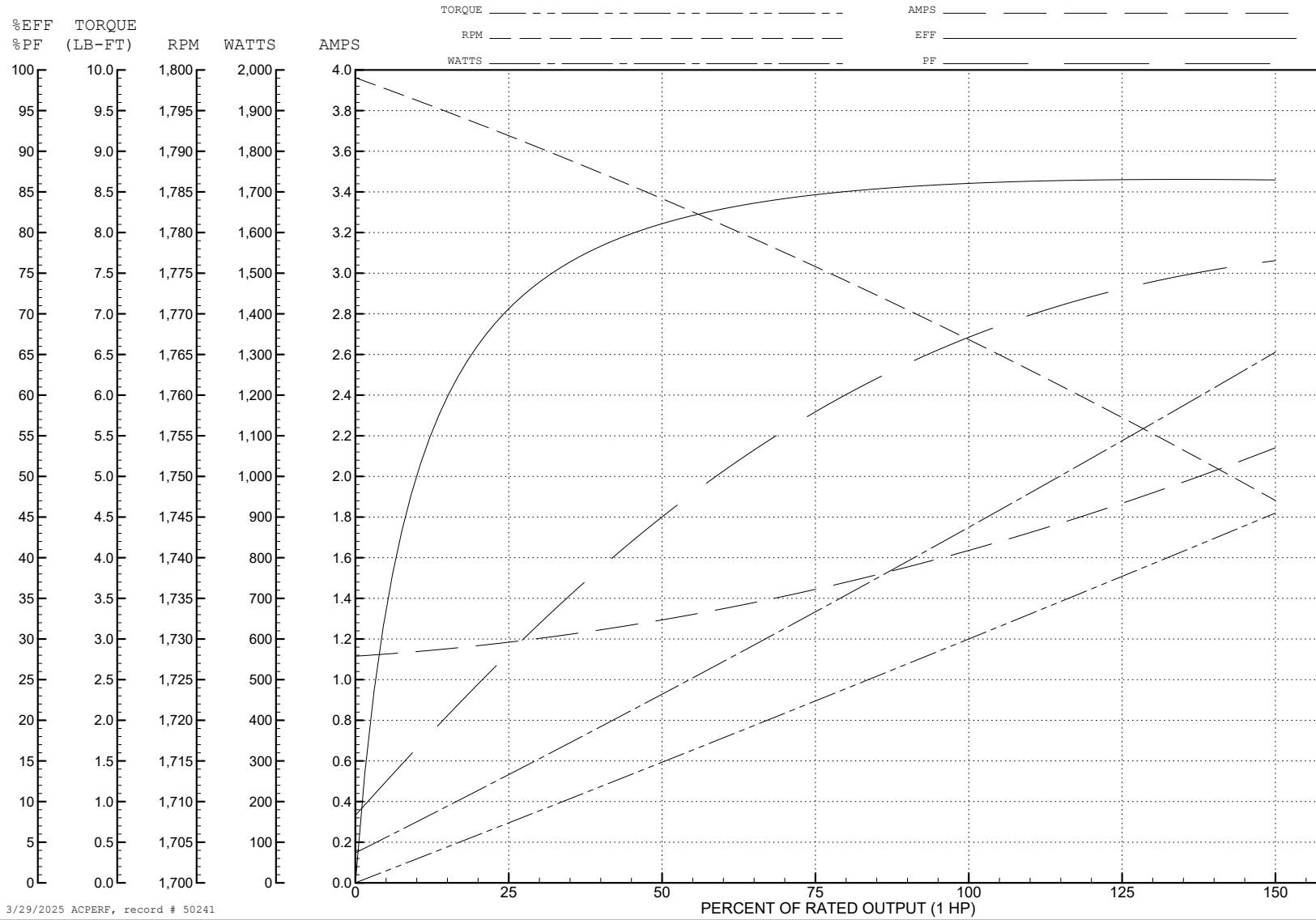

3/29/2025 ACPERF, record # 50241

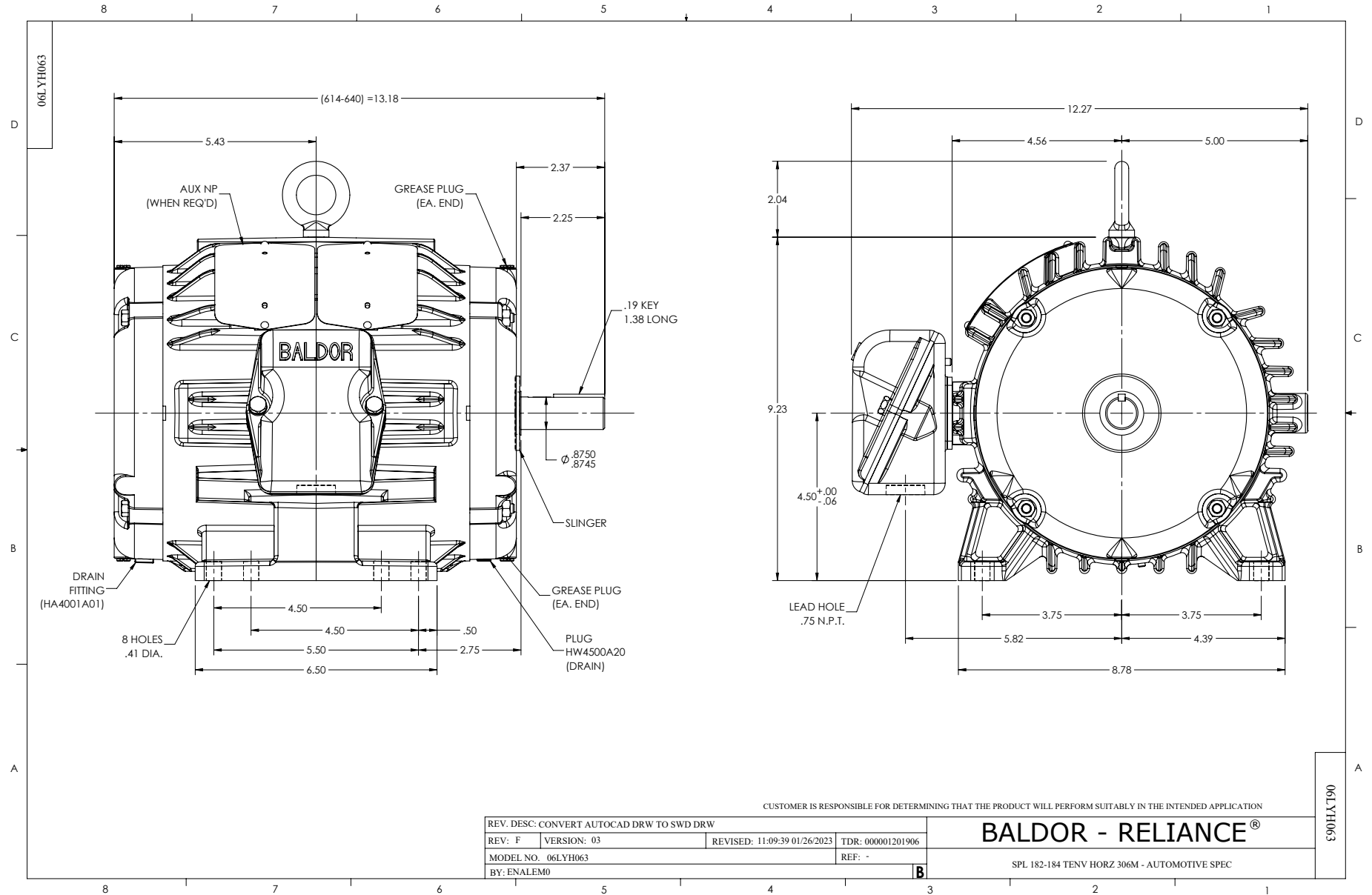

CD0006

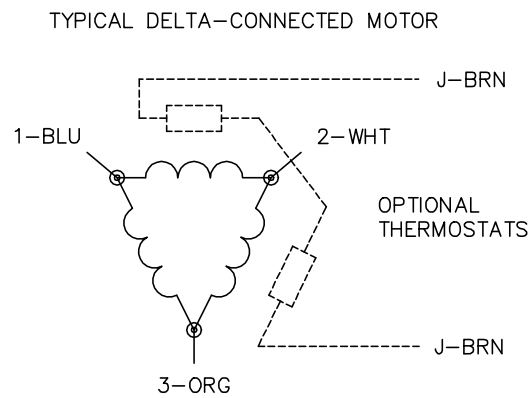
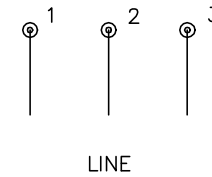
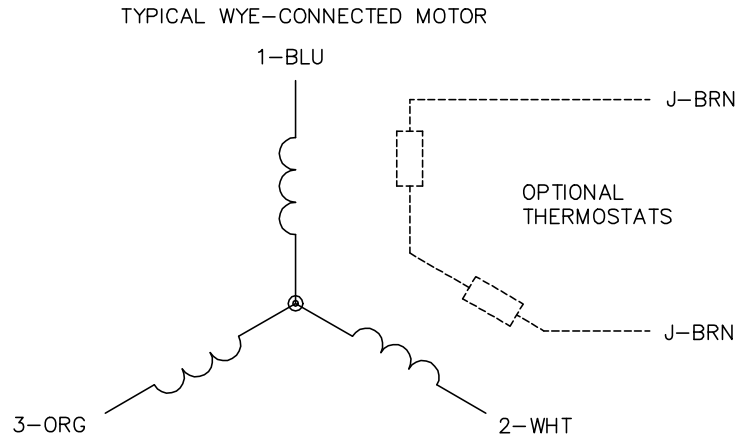

NOTES:

1. THREE LEAD MOTOR MAY BE EITHER WYE CONNECTED OR DELTA CONNECTED.
2. INTERCHANGE ANY TWO LINE LEADS TO REVERSE ROTATION.
3. OPTIONAL THERMOSTATS ARE PROVIDED WHEN SPECIFIED.
4. ACTUAL NUMBER OF INTERNAL PARALLEL CIRCUITS MAY VARY.
5. LEAD COLORS ARE OPTIONAL. LEADS MUST BE NUMBERED AS SHOWN.

CD0006

REV. DESC: ADD CLASS CONN00000007		
REV. LTR: E	VERSION: 01	TDR: 000001099922
FILE: \AAA\00005\141	REVISED: 10:24:49 02/19/2019	BY: ENBRIRO
MTL: -	© □	

**BALDOR - RELIANCE®**

3PH, SV, 3 LEADS, WYE OR DELTA CONNECTED

SH 1 of 1