

BALDOR • RELIANCE

Customer information packet

AFM3529

1HP, 3450RPM, 3PH, 60HZ, 56Z, 3416M, TEAO, F1

Class - None

Division - Not Applicable

Specifications

Enclosure	TEAO
Frame	56Z
Frame Material	Steel
Frequency	60.00 Hz
Haz Area Class and Group	None
Haz Area Division	Not Applicable
Motor Letter Type	Three Phase
Output @ Frequency	1.000 HP @ 60 HZ
Phase	3
Synchronous Speed @ Frequency	3600 RPM @ 60 HZ
Voltage @ Frequency	230.0 V @ 60 HZ 460.0 V @ 60 HZ
Agency Approvals	CSA UR
Ambient Temperature	40 °C
Auxillary Box	No Auxillary Box
Auxillary Box Lead Termination	None
Base Indicator	Rigid
Bearing Grease Type	Polyrex EM (-20F +300F)
Blower	None
Current @ Voltage	1.800 A @ 460.0 V 3.600 A @ 230.0 V 4.100 A @ 208.0 V
Design Code	B
Drip Cover	No Drip Cover
Duty Rating	CONT
Efficiency @ 100% Load	75.5 %
Electrically Isolated Bearing	Not Electrically Isolated
Feedback Device	NO FEEDBACK
Front Face Code	Terminal Panel
Front Shaft Indicator	None
Heater Indicator	No Heater

Part detail

Revision	AQ
Type	AC
Mech. spec.	34K062
Base	
Status	PRD/A
Elec. spec.	34WGO282
Layout	34LYK062
Eff. date	01-02-2025
CD Diagram	CD0005
Poles	02
Leads	9#18 14"LG +/-5" Y
Proprietary	False
Created date	01-01-0001

High Voltage Full Load Amps	1.8 a
Insulation Class	B
Inverter Code	Not Inverter
KVA Code	H
Lifting Lugs	No Lifting Lugs
Locked Bearing Indicator	No Locked Bearing
Motor Lead Exit	Lead Hole
Motor Lead Quantity/Wire Size	9 @ 18 AWG
Motor Lead Termination	Flying Leads
Motor Standards	NEMA
Motor Type	3416M
Mounting Arrangement	F1
Number of Poles	2
Overall Length	10.97 IN
Power Factor	71
Product Family	General Purpose
Pulley End Bearing Type	Sealed Bearing
Pulley Face Code	Standard
Pulley Shaft Indicator	Tapped & Key
Rodent Screen	None
Service Factor	1.25
Shaft Diameter	0.625 IN
Shaft Extension Location	Pulley End
Shaft Ground Indicator	No Shaft Grounding
Shaft Rotation	Reversible
Shaft Slinger Indicator	No Slinger
Speed	3450 rpm
Speed Code	Single Speed
Starting Method	Direct on line
Thermal Device - Bearing	None
Thermal Device - Winding	None
Vibration Sensor Indicator	No Vibration Sensor

Nameplate

NP1279L									
CAT.NO.	AFM3529								
SPEC.	34K62-282								
HP	1								
VOLTS	230/460								
AMP	3.6/1.8								
RPM	3450								
FRAME	56Z	HZ	60	PH	3				
SER.F.	1.25	CODE	H	DES	B	CL	B		
NEMA-NOM-EFF	75.5	PF	71						
RATING	40C AMB-CONT								
CC									
DE	6203	ODE	6203						
ENCL	TEAO	SN							
	SFA 4/2								

Parts list

Part number	Description	Quantity
SA008209	SA 34K62-282	1.000 ea
RA004656	RA 34K62-282	1.000 ea
34EP3204A01SP	FR ENDPLATE, MACH	1.000 ea
11XW0832G06	#8-32 X 3/8, TAPTITE II, HEX WSHR SLTD	1.000 ea
SP1000A09	TERM BOARD, MODEL 34 SW, (RPL SP1000A01)	1.000 ea
ML1400DF18	18 AWG,BLANK,GREEN w/YELLOW STRIPE	16.000 in
WD1000D88	T&B RA873M,TRM.INS RING,#10 STUD,22-18 G	1.000 ea
RM1001A01	GROMMET "MIDSTATES"	1.000 ea
HW5100A03	WAVY WASHER (W1543-017)	1.000 ea
34EP3102A02SP	FR/PU ENDPLATE, MACH	1.000 ea
XY1032A02	10-32 HEX NUT DIRECTIONAL SERRATION	4.000 ea
34CB4501SP	TERMINAL BOX LID, STAMPED X (PLATED)	1.000 ea
34GS1005	GASKET, TERM PLATE LID	1.000 ea
51XW0832A07	8-32 X .44, TAPTITE II, HEX WSHR SLTD SE	2.000 ea
51XW0832A07	8-32 X .44, TAPTITE II, HEX WSHR SLTD SE	2.000 ea
HW2501D13	KEY, 3/16 SQ X 1.375	1.000 ea
HA7000A04	KEY RETAINER 0.625 DIA SHAFTS	1.000 ea
MG1025C02	WILKOFASG SG, 787.105, TAN	0.014 ga
85XU0407S04	4X1/4 U DRIVE PIN STAINLESS	2.000 ea
HA3100A12	THRUBOLT 10-32 X 7.375	4.000 ea
LB1624	COMBINED WARNING LABEL, ISO/ANSI PICTOGR	1.000 ea
LC0145B01	CONNECTION LABEL	1.000 ea
NP1279L	ALUM FARM DUTY UL CSA CC	1.000 ea
35PA1066	PKG GRP, PRINT PK1008A06	1.000 ea
MN416A01	TAG-INSTAL-MAINT no wire (2500bx)4/22	1.000 ea

AC Induction Motor Performance Data

Record # 6568

Typical performance - not guaranteed values

Winding: 34WG0282-R001		Type: 3416M		Enclosure: TEFC	
Nameplate Data			460 V, 60 Hz: High Voltage Connection		
Rated Output (HP)	1	Full Load Torque	1.5 LB-FT		
Volts	230/460	Start Configuration	direct on line		
Full Load Amps	3.6/1.8	Breakdown Torque	6.5 LB-FT		
R.P.M.	3450	Pull-up Torque	5.2 LB-FT		
Hz	60 Phase	3	Locked-rotor Torque	5.5 LB-FT	
NEMA Design Code	B KVA Code	H	Starting Current	11 A	
Service Factor (S.F.)		1.25	No-load Current	1.1 A	
NEMA Nom. Eff.	75.5 Power Factor	71	Line-line Res. @ 25°C	16.7 Ω	
Rating - Duty		40C AMB-CONT	Temp. Rise @ Rated Load	71°C	
S.F. Amps		4/2	Temp. Rise @ S.F. Load	85°C	

Load Characteristics 460 V, 60 Hz, 1 HP

% of Rated Load	25	50	75	100	125	150	S.F.
Power Factor	37	53	68	76	77	76	77
Efficiency	61.2	72.1	76.8	77.7	77.2	76.2	77.2
Speed	3558	3524	3476	3434	3390	3349	3390
Line amperes	1.17	1.25	1.45	1.65	1.9	2.15	1.9

ABB Motors and Mechanical Inc.

WINDING # 34WG0282

Typical performance - not guaranteed values.

1 HP 3 PH 60 HZ 3450 RPM 460 V 3416M

TORQUES (LB-FT): PO=6.5 PU=5.2 LR=5.5 LRA=11

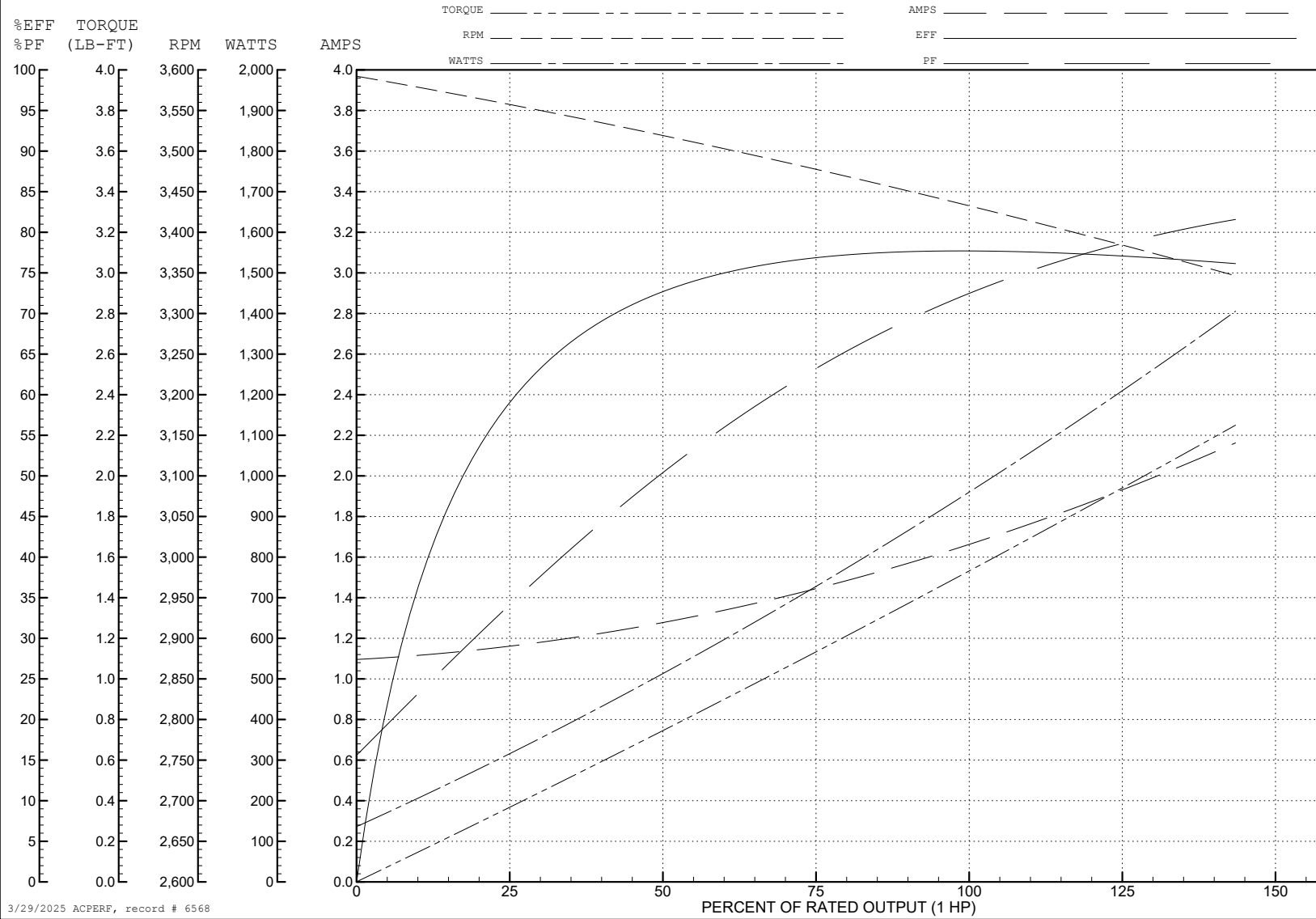

3/29/2025 ACPERF, record # 6568

34LYK062

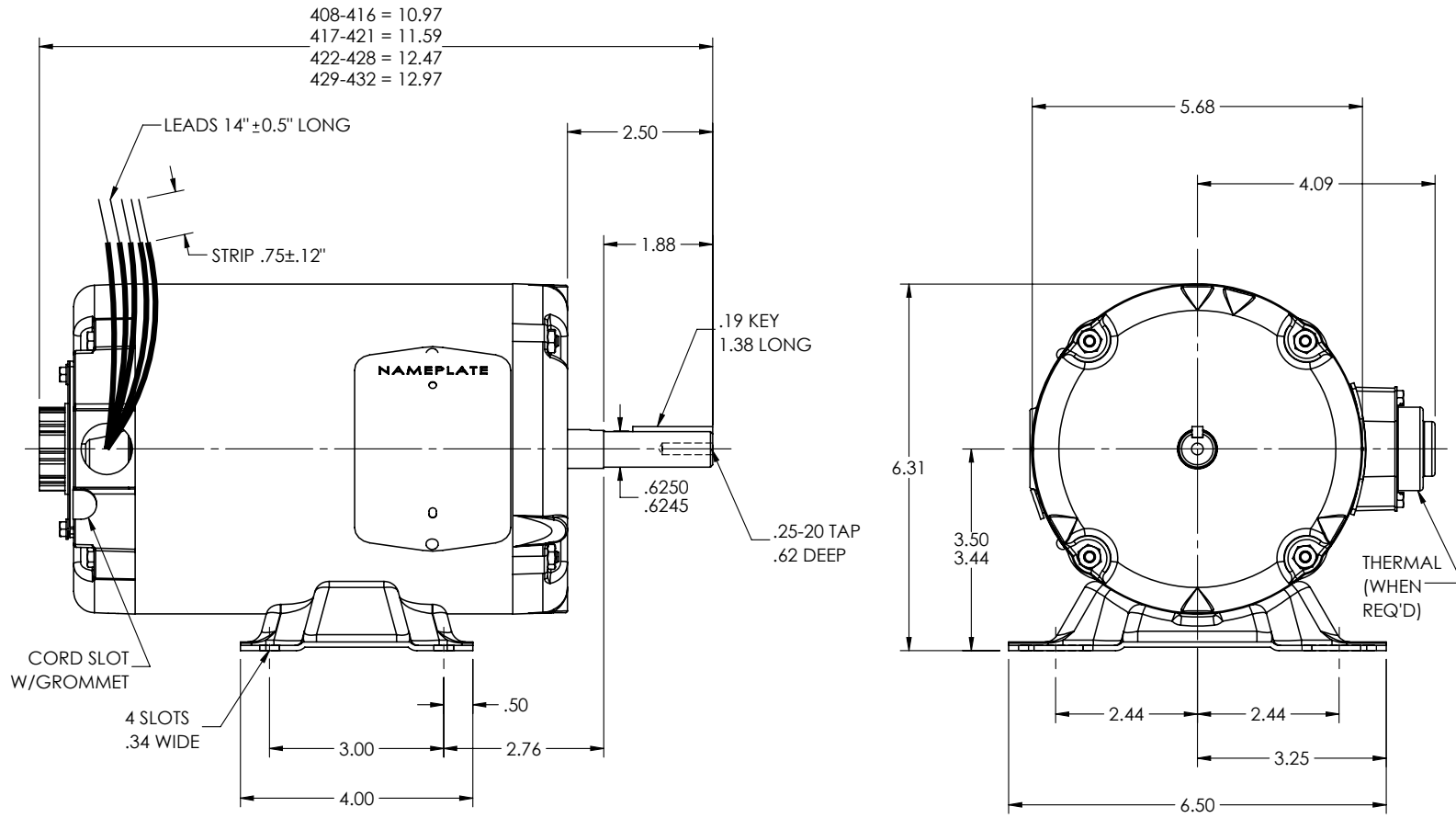

CUSTOMER IS RESPONSIBLE FOR DETERMINING THAT THE PRODUCT WILL PERFORM SUITABLY IN THE INTENDED APPLICATION

REV. DESC: LOAD TO SOLIDWORKS - REV J			
REV: K	VERSION: 02	REVISED: 09:26:24 01/06/2023	TDR: 000001201165
34LYK062	MODEL NO. 34LYK062	REF: -	
	BY: ENFRAJ0		

BALDOR - RELIANCE®

HORZ MODEL 34M NEMA 56Z TENV W/TERM PANEL & .25-20 TAP

34LYK062

CD0005



LOW VOLTAGE
(2Y)



LINE

HIGH VOLTAGE
(1Y)



LINE

NOTES:

1. INTERCHANGE ANY TWO LINE LEADS TO REVERSE ROTATION.
2. OPTIONAL THERMOSTATS ARE PROVIDED WHEN SPECIFIED.
3. ACTUAL NUMBER OF INTERNAL PARALLEL CIRCUITS MAY BE A MULTIPLE OF THOSE SHOWN ABOVE.
4. LEAD COLORS ARE OPTIONAL. LEADS MUST ALWAYS BE NUMBERED AS SHOWN.

CD0005

REV. DESC: REVISE TO SHOW OPTIONAL COLORS			
REV. LTR: E	BY: JLP	REVISED: 01/19/99 10:15	TDR: 0171435
S00000		FILE: AAA00005140	MDL: -
		MTL: -	

BALDOR ELECTRIC Co.

3PH, DV, 9 LEADS