



Customer information packet

CECP83581T-5

1HP, 1770RPM, 3PH, 60HZ, 143TC, 0520M, TEFC, F1

Class - CLI GP A,B,C,D

Division - Division II

Specifications

Enclosure	TEFC
Frame	143TC
Frame Material	Iron
Frequency	60.00 Hz
Haz Area Class and Group	CL I GP A,B,C,D
Haz Area Division	Division II
Motor Letter Type	Three Phase
Output @ Frequency	1.000 HP @ 60 HZ
Phase	3
Synchronous Speed @ Frequency	1800 RPM @ 60 HZ
Voltage @ Frequency	575.0 V @ 60 HZ
Agency Approvals	CCSA US CSA EEV NEMA PREMIUM NEMA_PREMIUM UR
Ambient Temperature	40 °C
Auxillary Box	No Auxillary Box
Auxillary Box Lead Termination	None
Base Indicator	Rigid
Bearing Grease Type	Polyrex EM (-20F +300F)
Blower	None
Constant Torque Speed Range	1.2
Current @ Voltage	1.200 A @ 575.0 V
Design Code	B
Drip Cover	No Drip Cover
Duty Rating	CONT
Efficiency @ 100% Load	85.5 %
Electrically Isolated Bearing	Not Electrically Isolated
Feedback Device	NO FEEDBACK
Front Shaft Indicator	None
Haz Area Temp Code	T4

Part detail

Revision	D
Type	AC
Mech. spec.	05E943
Base	
Status	PRD/A
Elec. spec.	05WGX567
Layout	05LYE943
Eff. date	04-10-2023
CD Diagram	CD0006
Poles	04
Leads	3#18
Proprietary	False
Created date	03-11-2022

Heater Indicator	No Heater
High Voltage Full Load Amps	1.2 a
Insulation Class	F
Inverter Code	Inverter Ready
KVA Code	M
Lifting Lugs	Standard Lifting Lugs
Locked Bearing Indicator	Locked Bearing
Max Speed	2700 rpm
Motor Lead Quantity/Wire Size	3 @ 18 AWG
Motor Lead Termination	Flying Leads
Motor Standards	NEMA
Motor Type	0520M
Mounting Arrangement	F1
Number of Poles	4
Overall Length	13.38 IN
Power Factor	72
Product Family	Chem Process S/P 32-8 IEEE 841
Pulley End Bearing Type	Ball
Pulley Face Code	Standard
Pulley Shaft Indicator	Standard
Rodent Screen	None
Service Factor	1.15
Shaft Diameter	0.875 IN
Shaft Ground Indicator	No Shaft Grounding
Shaft Rotation	Reversible
Shaft Slinger Indicator	Shaft Slinger
Speed	1770 rpm
Speed Code	Single Speed
Starting Method	Direct on line
Thermal Device - Bearing	None
Thermal Device - Winding	None
Vibration Sensor Indicator	No Vibration Sensor
Winding Thermal 1	None
Winding Thermal 2	None

Nameplate

NP4328									
CAT.NO.	CECP83581T-5								
SPEC.	05E943X567G1								
HP	1 TE					IP	56		
VOLTS	575								
AMPS	1.2								
R.P.M.	1770								
FRAME	143TC		HZ	60		PH	3		
SER.F.	1.15	CODE	M	DES.	B	CLASS	F		
RATING	40C AMB-CONT								
SN									
DE	6205		ODE	6205					
NEMA NOM. EFF.	85.5		P.F.	72					
GUAR. MIN. EFF.	82.5	CC	010A						
T. CODE	T4		TEMP=	135					

NP3186

SPEC.	05E943X567G1		
ABMA DE BRG	25BC02X30X		
ABMA ODE BRG	25BC02X30X		
GREASE	POLYREX EM		
MOTOR WEIGHT	70	ROTOR BARS	28
		STATOR BARS	36
MAX. R.P.M.	2700	MAX. KVAR	0.42
	SFA 1.33		
INV.TYPE	PWM		
T=	135		
CHP	60	TO	90
CT	1.2	TO	60
VT	-0	TO	60
HTR-VOLTS		HTR-AMPS	
HTR-WATTS		MAX. SPACE HEATER TEMP.	

Parts list

Part number	Description	Quantity
SA408898	SA 05E943X567G1	1.000 ea
RA400445	RA 05E943X567G1	1.000 ea
34FN3002B01	EXTERNAL FAN, PLASTIC, .637/.639 HUB W/ 3/8-16 EYEBOLT	1.000 ea
HW3201A05	3/8-16 EYEBOLT	1.000 ea
06CB1001A01G	CONDUIT BOX, MACH GRAY	1.000 ea
RM1016	LEAD SEPARATOR GASKET - 305/306 C.P.MOTO	1.000 ea
51XW2520A12	SCREW, HEX SER SLT HD, ZN, 1/4-20 X .75	2.000 ea
11XW1032G06	10-32 X .38, TAPTITE II, HEX WSHR SLTD U	1.000 ea
HW3001B01	BRASS CUP WASHER, FOR #10 SCREW	1.000 ea
10XN2520S06	1/4 20X3/8 HX HD CAP S.S.	1.000 ea
WD1000B16	T&B CX70TN OR L70P TERMINAL LUG	1.000 ea
51XN1032A20	10-32 X 1 1/4 HX WS SL SR	2.000 ea
05EP1100A02G	FREP TEFC 205,GRSR,RLF,DRAIN FITTING,INP	1.000 ea
HW4601B22	INPRO SEAL, 205 BRG, MINI66	1.000 ea
HW4500A01	1641B(ALEMITE)400 UNIV, GREASE FITT	1.000 ea
HA4051A00	PLASTIC CAP FOR GREASE FITTING	1.000 ea
HW4500A17	317400 ALEMITE GREASE RELIEF	1.000 ea
HA4010A01	T-DRAIN PLUG,416 S.S.,W/ 1/4-28 THD & .0	1.000 ea
HW5100A05	WVY WSHR F/205 & 304 BRGS	1.000 ea
35EP1329A32G	EP ENCL 205 BRG,GRSR,RLF,NPT DRAIN,INPRO	1.000 ea
HW4601B22	INPRO SEAL, 205 BRG, MINI66	1.000 ea
HW4500A01	1641B(ALEMITE)400 UNIV, GREASE FITT	1.000 ea
HA4051A00	PLASTIC CAP FOR GREASE FITTING	1.000 ea
HW4500A17	317400 ALEMITE GREASE RELIEF	1.000 ea
HA4010A01	T-DRAIN PLUG,416 S.S.,W/ 1/4-28 THD & .0	1.000 ea
51XN1032A20	10-32 X 1 1/4 HX WS SL SR	2.000 ea
HA3100A28	THRUBOLT 10-32 X 8.187	4.000 ea
35FH1000A19G	35FH1000A19 W/GRAY FLUIDIZ	1.000 ea
10XN2520A16	1/4-20 X 1 HEX HEAD CAP SCR, ZINC PLATED	3.000 ea
HW1001A25	LOCKWASHER 1/4, ZINC PLT .493 OD, .255 I	3.000 ea
WD4100A03	DE-750 HEYCO PLUG 62MP0750 MICRO PLASTIC	1.000 ea

06CB1503A01G	LIPPED CONDUIT BOX LID, MACH GRAY EPOXY	1.000 ea
06GS1009	GASKET, KOBX LID, 1/8" THICK BLACK NEOPR	1.000 ea
10XN2520A12	1/4-20 X 3/4 HEX HEAD CAP	2.000 ea
HW1001A25	LOCKWASHER 1/4, ZINC PLT .493 OD, .255 I	2.000 ea
HW2501D13	KEY, 3/16 SQ X 1.375	1.000 ea
HA7000A01	KEY RETAINER 7/8" DIA SHAFT	1.000 ea
MJ5001A02	732 CL SEALANT 3 OZ DIXIE BEARING 289100	0.010 ea
MJ5001A27	32220KN GRAY SEALER *MIN BUY 4 QTS=1GAL	0.001 qt
MJ1000A73	INPRO P-80 ASSEMBLY LUB./ 1 QT. CONTAIN	0.001 qt
85XU0407S04	4X1/4 U DRIVE PIN STAINLESS	4.000 ea
LB1624	COMBINED WARNING LABEL, ISO/ANSI PICTOGR	1.000 ea
LT0019A00	MOTOR NO-LOAD PERFORMANCE DATA SHEET	1.000 ea
WD1000D21	TRM,T&B #B71M,RING,18-14,.25,NON-INSL	3.000 ea
MJ1000A02	GREASE, POLYREX EM EXXON	0.050 lb
MG1025N19	WILKOFASST, 778.50, RELIANCE BLUE-GREEN 8	0.022 ga
LC0006	CONNECTION LABEL	1.000 ea
LB1449	DIV-2/NEC WARNING LABEL	1.000 ea
NP4328	SS IEEE841-2021 DIV-2 UL CSA-C US EEV	1.000 ea
NP3186	SS IEEE841 INV AUX DATA INFORMATION	1.000 ea
36PA1000	PKG GRP, PRINT PK1016A06	1.000 ea
MN416A01	TAG-INSTAL-MAINT no wire (2500bx)4/22	1.000 ea
FE-0000002	ZRTG FE ASSEMBLY	1.000 ea
PE-0000002	ZRTG PE ASSEMBLY	1.000 ea

AC Induction Motor Performance Data

Record # 89183

Typical performance - not guaranteed values

Winding: 05WGX567-R001		Type: 0520M		Enclosure: TEFC	
Nameplate Data			575 V, 60 Hz: Single Voltage Motor		
Rated Output (HP)		1	Full Load Torque		2.96 LB-FT
Volts		575	Start Configuration		direct on line
Full Load Amps		1.2	Breakdown Torque		11.89 LB-FT
R.P.M.		1770	Pull-up Torque		7.42 LB-FT
Hz	60 Phase	3	Locked-rotor Torque		9.63 LB-FT
NEMA Design Code	B KVA Code	M	Starting Current		10.72 A
Service Factor (S.F.)		1.15	No-load Current		0.768 A
NEMA Nom. Eff.	85.5 Power Factor	72	Line-line Res. @ 25°C		32.1 Ω
Rating - Duty		40C AMB-CONT	Temp. Rise @ Rated Load		31°C
S.F. Amps			Temp. Rise @ S.F. Load		37°C
			Locked-rotor Power Factor		62.9842
			Rotor inertia		0.144 lb-ft ²

Load Characteristics 575 V, 60 Hz, 1 HP

% of Rated Load	25	50	75	100	125	150	S.F.
Power Factor	33	51	64	72	78	82	76
Efficiency	72.5	82.2	85.1	85.4	85.1	84	85.2
Speed	1792	1784	1776	1768	1758	1748	1762
Line amperes	0.803	0.9	1.04	1.21	1.41	1.63	1.33

ABB Motors and Mechanical Inc.

WINDING # 05WGX567

Typical performance - not guaranteed values.

1 HP 3 PH 60 HZ 1770 RPM 575 V 0520M

TORQUES (LB-FT): PO=11.89 PU=7.42 LR=9.63 LRA=10.72

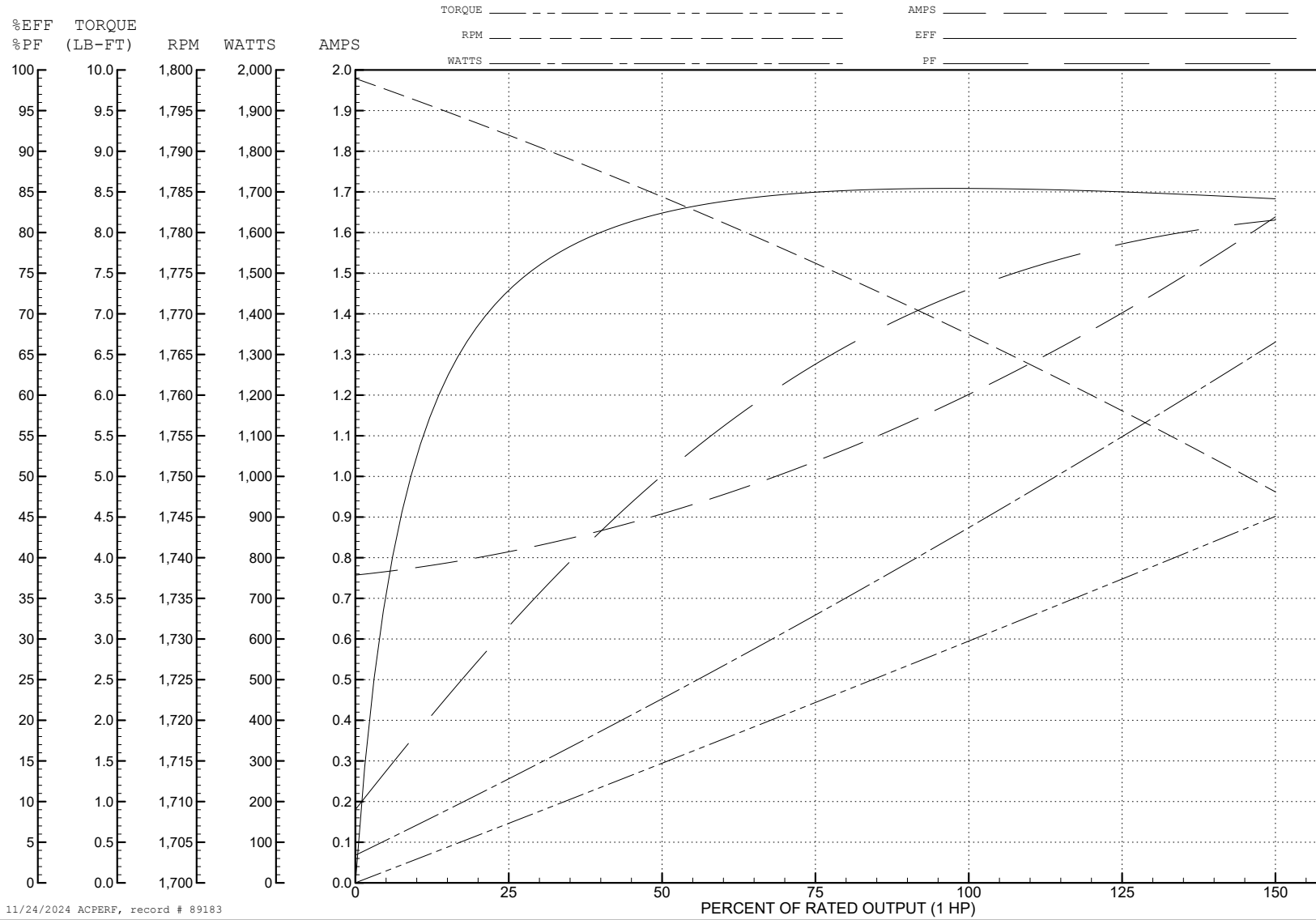

11/24/2024 ACPERF, record # 89183

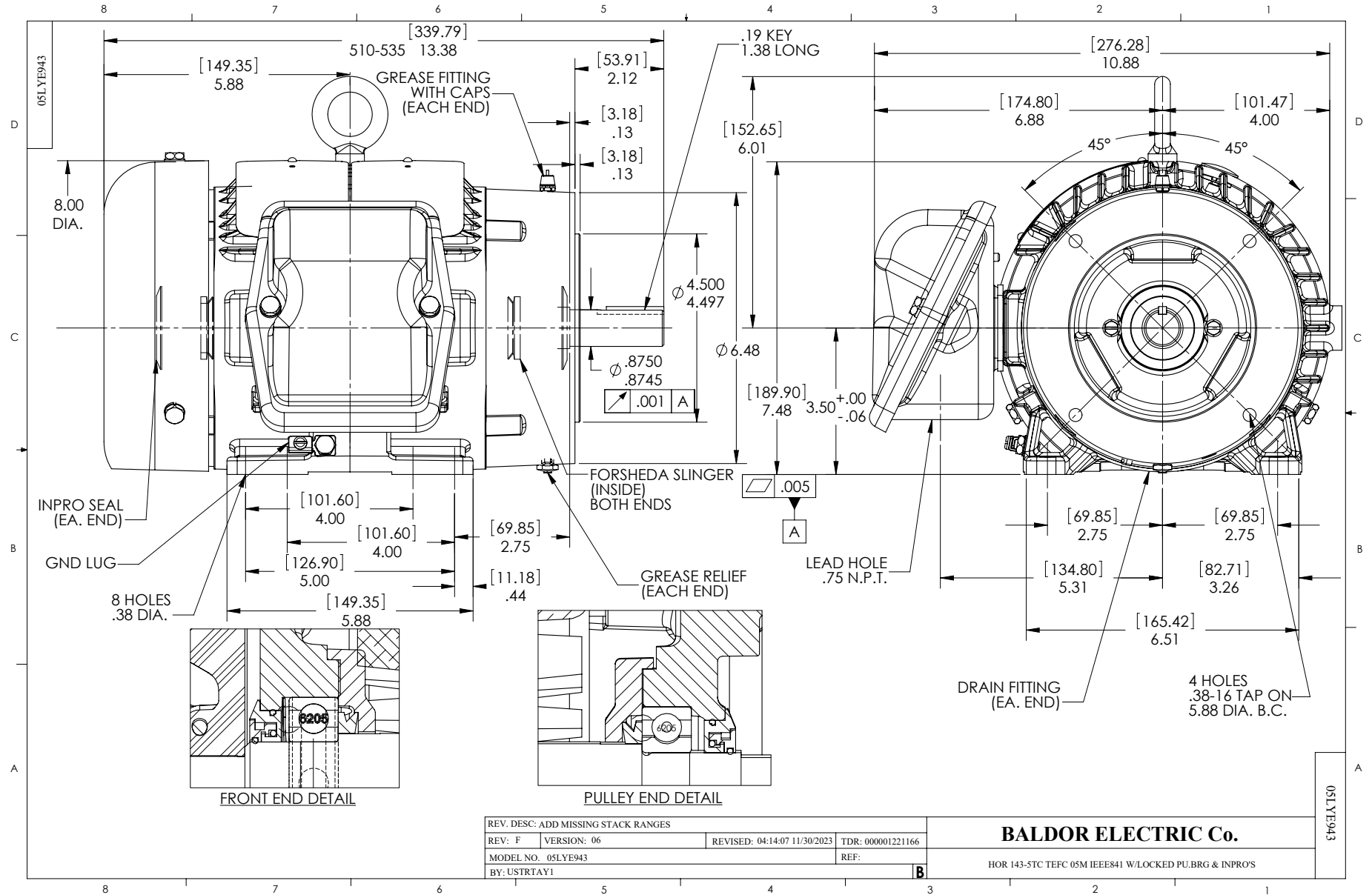

CD0006

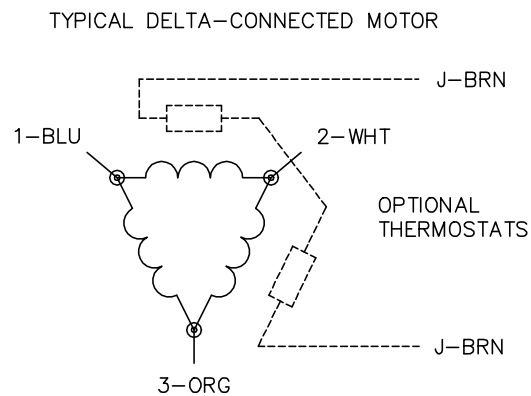
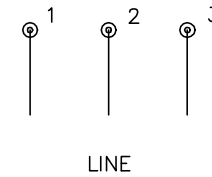
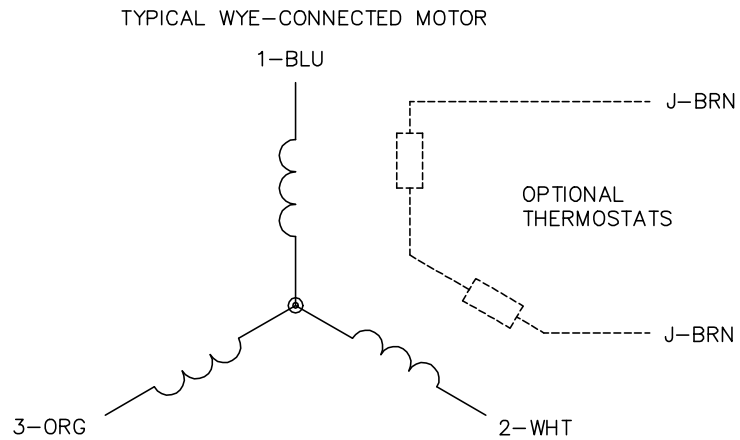

NOTES:

1. THREE LEAD MOTOR MAY BE EITHER WYE CONNECTED OR DELTA CONNECTED.
2. INTERCHANGE ANY TWO LINE LEADS TO REVERSE ROTATION.
3. OPTIONAL THERMOSTATS ARE PROVIDED WHEN SPECIFIED.
4. ACTUAL NUMBER OF INTERNAL PARALLEL CIRCUITS MAY VARY.
5. LEAD COLORS ARE OPTIONAL. LEADS MUST BE NUMBERED AS SHOWN.

CD0006

REV. DESC: ADD CLASS CONN00000007		
REV. LTR: E	VERSION: 01	TDR: 000001099922
FILE: \AAA\00005\141	REVISED: 10:24:49 02/19/2019	BY: ENBRIRO
MTL: -	© □	

BALDOR - RELIANCE®

3PH, SV, 3 LEADS, WYE OR DELTA CONNECTED

SH 1 of 1