

**BALDOR • RELIANCE**

---

# Customer information packet

## CEM2334T

20HP, 1770RPM, 3PH, 60HZ, 256TC, 0960M, TEFC, F

Class - None

Division - Not Applicable

Copyright © All product information within this document is subject to ABB Motors and Mechanical Inc. copyright © protection, unless otherwise noted.

11/24/2024 11:59:31 AM

## Specifications

Enclosure	TEFC
Frame	256TC
Frame Material	Iron
Frequency	60.00 Hz
Haz Area Class and Group	None
Haz Area Division	Not Applicable
Motor Letter Type	Three Phase
Output @ Frequency	20.000 HP @ 60 HZ
Phase	3
Synchronous Speed @ Frequency	1800 RPM @ 60 HZ
Voltage @ Frequency	460.0 V @ 60 HZ 230.0 V @ 60 HZ
Agency Approvals	NEMA PREMIUM NEMA_PREMIUM UR CSA EEV
Ambient Temperature	40 °C
Auxillary Box	No Auxillary Box
Auxillary Box Lead Termination	None
Base Indicator	Rigid
Bearing Grease Type	Polyrex EM (-20F +300F)
Blower	None
Current @ Voltage	48.000 A @ 230.0 V 52.000 A @ 208.0 V 24.000 A @ 460.0 V
Design Code	A
Drip Cover	No Drip Cover
Duty Rating	CONT
Efficiency @ 100% Load	93.0 %
Electrically Isolated Bearing	Not Electrically Isolated
Feedback Device	NO FEEDBACK
Front Face Code	Standard

## Part detail

Revision	U
Type	AC
Mech. spec.	09C102
Base	
Status	PRD/A
Elec. spec.	09WGT459
Layout	09LYC102
Eff. date	03-19-2024
CD Diagram	CD0180
Poles	04
Leads	9#10
Proprietary	False
Created date	11-17-2017

Front Shaft Indicator	None
Heater Indicator	No Heater
High Voltage Full Load Amps	24.0 a
Insulation Class	F
Inverter Code	Inverter Ready
KVA Code	J
Lifting Lugs	Standard Lifting Lugs
Locked Bearing Indicator	Locked Bearing
Motor Lead Exit	Ko Box
Motor Lead Quantity/Wire Size	9 @ 10 AWG
Motor Lead Termination	Flying Leads
Motor Standards	NEMA
Motor Type	0960M
Mounting Arrangement	F1
Number of Poles	4
Overall Length	23.86 IN
Power Factor	83
Product Family	General Purpose
Pulley End Bearing Type	Ball
Pulley Face Code	C-Face
Pulley Shaft Indicator	Standard
Rodent Screen	None
Service Factor	1.15
Shaft Diameter	1.625 IN
Shaft Extension Location	Pulley End
Shaft Ground Indicator	No Shaft Grounding
Shaft Rotation	Reversible
Shaft Slinger Indicator	Shaft Slinger
Speed	1770 rpm
Speed Code	Single Speed
Starting Method	Direct on line
Thermal Device - Bearing	None
Thermal Device - Winding	None
Vibration Sensor Indicator	No Vibration Sensor

Winding Thermal 1	None
Winding Thermal 2	None

---

**Nameplate**

**NP3441LUA**

<b>CAT.NO.</b>	CEM2334T						
<b>SPEC</b>	09C102T459G1						
<b>HP</b>	20						
<b>VOLTS</b>	230/460						
<b>AMPS</b>	48/24						
<b>RPM</b>	1770						
<b>FRAME</b>	256TC	<b>HZ</b>	60	<b>PH</b>	3		
<b>SF</b>	1.15	<b>CODE</b>	J	<b>DES</b>	A	<b>CLASS</b>	F
<b>NEMA NOM. EFF</b>	93	<b>PF</b>	83				
<b>RATING</b>	40C AMB-CONT						
<b>CC</b>	010A						
<b>ENCL</b>	TEFC	<b>SER</b>					
<b>DE</b>	6309	<b>ODE</b>	6208				
<b>VPWM INVERTER READY</b>	SFA 54.4/27.2						
<b>CT6-60H(10:1)VT3-60H(20:1)</b>	50Hz 20HP 190/380V 58/29A						SF1.0

## Parts list

Part number	Description	Quantity
SA347949	SA 09C102T459G1	1.000 ea
RA336508	RA 09C102T459G1	1.000 ea
09FN3001D01SP	EXTERNAL FAN, PLASTIC (COMES W/SCREW FRO	1.000 ea
HW1002A63	WASHER, 5/8 HI-COLLAR SPRLCKWASHER	1.000 ea
09CB3003	CB W/1.75" DIA LD HL - 37, 39, 307 & 309	1.000 ea
09GS1000	GASKET-CONDUIT BOX, 1/16 THICK LEXIDE	1.000 ea
51XW2520A12	.25-20 X .75, TAPTITE II, HEX WSHR SLTD	4.000 ea
WD1000B16	T&B CX70TN OR L70P TERMINAL LUG	1.000 ea
59XW2520G07	.25-20X.44,HEX SER WSHR,TAPTITE 2,GREEN	1.000 ea
09EP1100A208	ENDPLATE, MACH	1.000 ea
HA3400A33	STUD- 3/8-16 X 4.96 HEX	4.000 ea
HW1001A38	LOCKWASHER 3/8, ZINC PLT .688 OD, .382 I	4.000 ea
XY3816A12	3/8-16 FINISHED NUT W/SERRATIONS	4.000 ea
HW5100A08	W3118-035 WVY WSHR (WB)	1.000 ea
10XN2520K36	1/4-20 X 2.25" HX HD SCRWGRADE 5, ZINC P	4.000 ea
HW1001A25	LOCKWASHER 1/4, ZINC PLT .493 OD, .255 I	4.000 ea
09EP1300A155	PUEP MACH W/309 BRG & "O" DRAIN, SLINGER	1.000 ea
10XN3816K28	3/8-16 X 1.75 HEX HD CAP SCREW, GRADE 5	4.000 ea
HW4600B44	V-RING SLINGER 1.500 X 1.810 X .28 VITON	1.000 ea
HW1001A38	LOCKWASHER 3/8, ZINC PLT .688 OD, .382 I	4.000 ea
HW1001A38	LOCKWASHER 3/8, ZINC PLT .688 OD, .382 I	4.000 ea
09CB3501SP	CONDUIT BOX LID FOR 09CB3001 & 09CB3002	1.000 ea
09GS1013SP	GS FOR 09CB3501, 12CB1500 & 12CB1503 LID	1.000 ea
51XW2520A12	.25-20 X .75, TAPTITE II, HEX WSHR SLTD	2.000 ea
HW2501G25	KEY, 3/8 SQ X 2.875	1.000 ea
HW4500A05	1669B ALEM/UNIV860 GR FTG X	1.000 ea
HW4500A17	317400 ALEMITE GREASE RELIEF	1.000 ea
HA4051A00	PLASTIC CAP FOR GREASE FITTING	1.000 ea
HA4066A01	PUSH IN T-DRAIN FITTING (BLACK)	1.000 ea
MJ1000A02	GREASE, POLYREX EM EXXON	0.080 lb
HA4051A00	PLASTIC CAP FOR GREASE FITTING	1.000 ea

HW4500A03	GREASE FITTING, .125 NPT 1610(ALEMITE) 8	1.000 ea
HW4500A17	317400 ALEMITE GREASE RELIEF	1.000 ea
HA4066A01	PUSH IN T-DRAIN FITTING (BLACK)	1.000 ea
HW2500A25	WOODRUFF KEY USA #1008 #BLOW CARBON STEE	1.000 ea
09FH4000SP	309 FH - BLACK PRIMER	1.000 ea
MG1050Y01	CELEROL BALDOR GOLD *** NLA IN 5 GALLON	0.050 ga
85XU0407S04	4X1/4 U DRIVE PIN STAINLESS	2.000 ea
LB1624	COMBINED WARNING LABEL, ISO/ANSI PICTOGR	1.000 ea
LC0181	CONNECTION LABEL	1.000 ea
NP3441LUA	AL SUPER-E VPWM INV RDY,UL EEV,NEMA PREM	1.000 ea
09PA1000	PACKAGING GROUP COMBINED PRINT	1.000 ea
MN416A01	TAG-INSTAL-MAINT no wire (2500bx)4/22	1.000 ea
FE-0000013	ZRTG FE ASSEMBLY	1.000 ea
LD7020E09	LEAD SET, 10AWG, 9 LEAD, 20" LONG LEADS	1.000 ea

**AC Induction Motor Performance Data**

Record # 67948

Typical performance - not guaranteed values

<b>Winding: 09WGT459-R001</b>		<b>Type: 0960M</b>		<b>Enclosure: TEFC</b>	
<b>Nameplate Data</b>			<b>460 V, 60 Hz: High Voltage Connection</b>		
<b>Rated Output (HP)</b>	20	<b>Full Load Torque</b>	59.27 LB-FT		
<b>Volts</b>	230/460	<b>Start Configuration</b>	direct on line		
<b>Full Load Amps</b>	48/24	<b>Breakdown Torque</b>	232 LB-FT		
<b>R.P.M.</b>	1770	<b>Pull-up Torque</b>	126 LB-FT		
<b>Hz</b>	60	<b>Locked-rotor Torque</b>	141 LB-FT		
<b>NEMA Design Code</b>	A	<b>Starting Current</b>	198 A		
<b>Service Factor (S.F.)</b>	1.15	<b>No-load Current</b>	10.4 A		
<b>NEMA Nom. Eff.</b>	93	<b>Line-line Res. @ 25°C</b>	0.33814 Ω		
<b>Rating - Duty</b>	40C AMB-CONT	<b>Temp. Rise @ Rated Load</b>	58°C		
<b>S.F. Amps</b>		<b>Temp. Rise @ S.F. Load</b>	70°C		
		<b>Locked-rotor Power Factor</b>	26.9		

**Load Characteristics 460 V, 60 Hz, 20 HP**

<b>% of Rated Load</b>	<b>25</b>	<b>50</b>	<b>75</b>	<b>100</b>	<b>125</b>	<b>150</b>	<b>S.F.</b>
<b>Power Factor</b>	45	67	78	83	86	87	85
<b>Efficiency</b>	89.2	93	93.7	93.6	93.1	92.4	93.3
<b>Speed</b>	1793.2	1786.4	1779.1	1771.9	1763.7	1755.3	1767
<b>Line amperes</b>	11.8	15	19.2	24	29.3	34.9	27.2



ABB Motors and Mechanical Inc.

WINDING # 09WGT459

Typical performance - not guaranteed values.

20 HP 3 PH 60 HZ 1770 RPM 460 V 0960M

TORQUES (LB-FT): PO=232 PU=126 LR=141 LRA=198

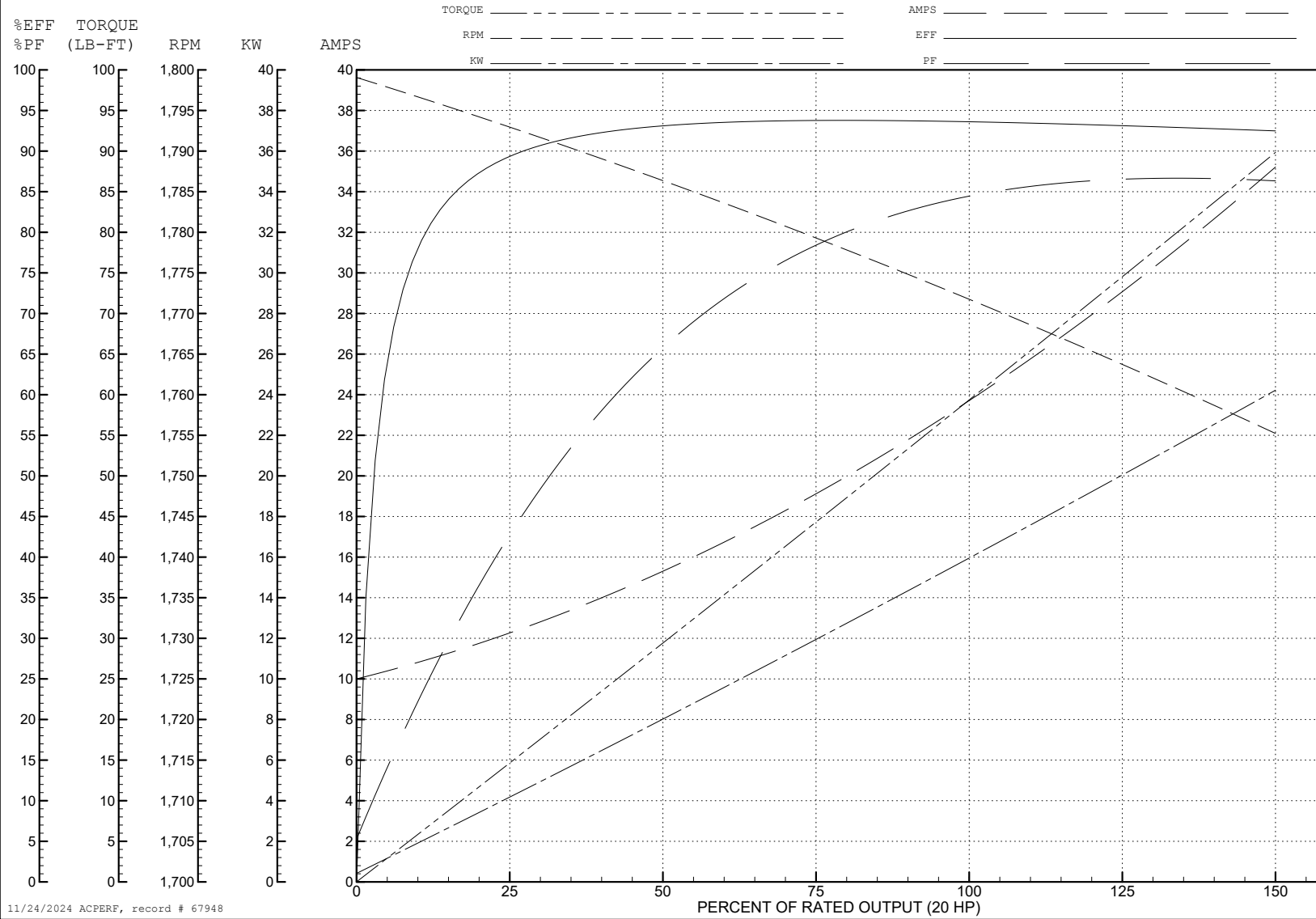

11/24/2024 ACPERF, record # 67948

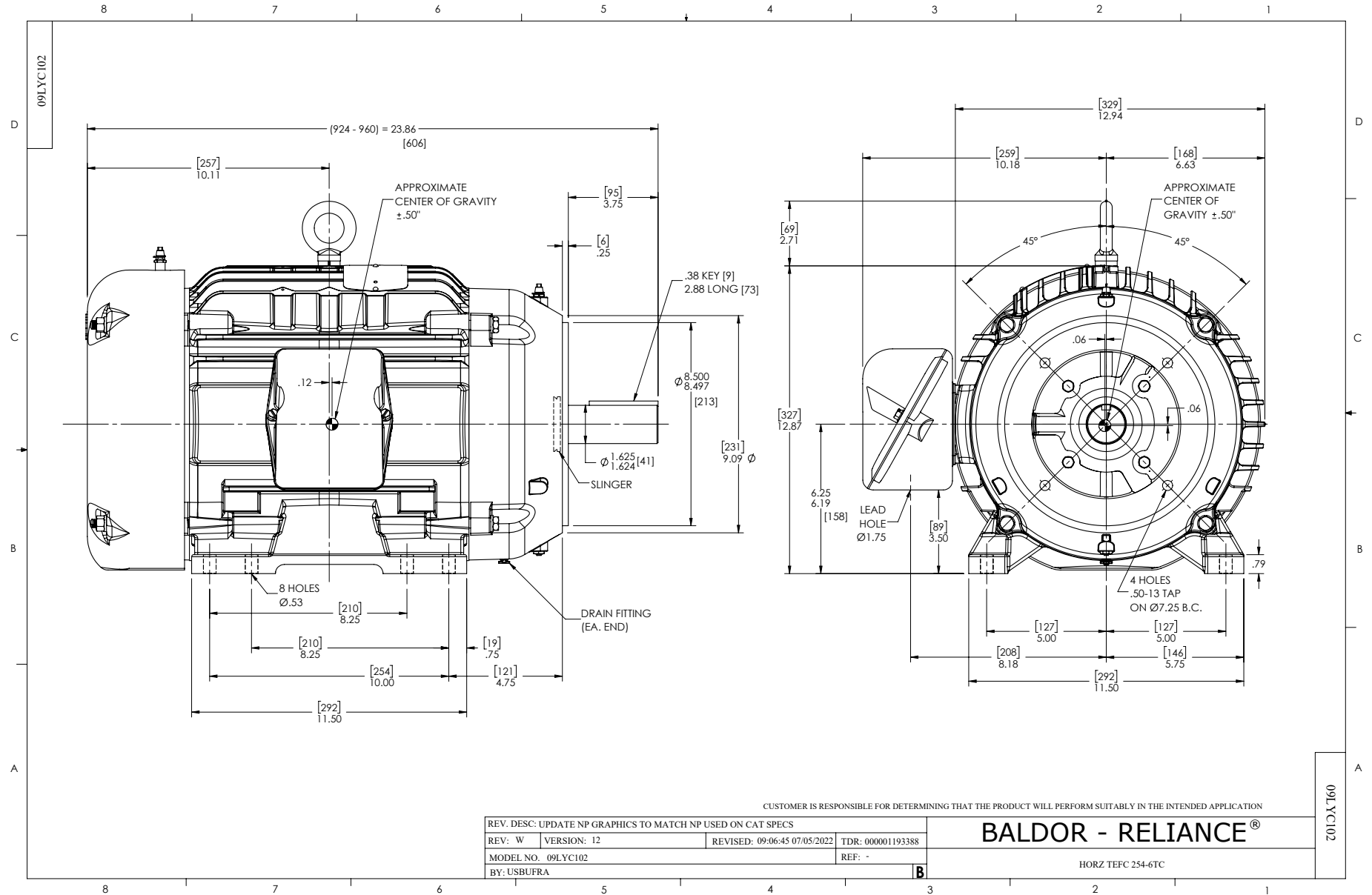

CD0180

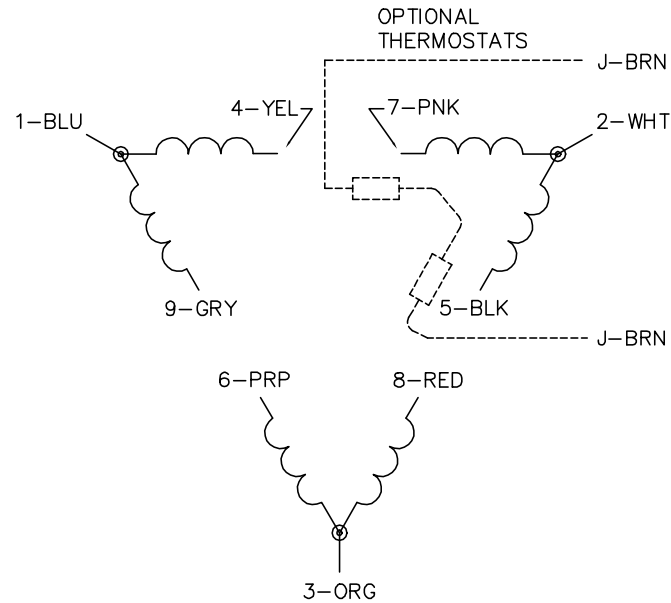

LOW VOLTAGE  
(2D)



HIGH VOLTAGE  
(1D)



NOTES:

1. INTERCHANGE ANY TWO LINE LEADS TO REVERSE ROTATION.
2. OPTIONAL THERMOSTATS ARE PROVIDED WHEN SPECIFIED.
3. ACTUAL NUMBER OF INTERNAL PARALLEL CIRCUITS MAY BE A MULTIPLE OF THOSE SHOWN ABOVE.
4. LEAD COLORS ARE OPTIONAL. LEADS MUST ALWAYS BE NUMBERED AS SHOWN.

CD0180

REV. DESC: ADD CLASS CONN00000007		
REV. LTR: D	VERSION: 01	TDR: 000001099922
FILE: \AAA\00005\148	REVISED: 10: 25: 29 02/19/2019	BY: ENBRIRO
MTL: -	© □	

**BALDOR - RELIANCE®**

3PH, DV, 9 LEADS, DELTA CONNECTION

SH 1 of 1