

BALDOR • RELIANCE

Customer information packet

CEM3584T

1.5HP, 1760RPM, 3PH, 60HZ, 145TC, 0524M, TEFC

Class - None

Division - Not Applicable

Specifications

Enclosure	TEFC
Frame	145TC
Frame Material	Iron
Frequency	60.00 Hz
Haz Area Class and Group	None
Haz Area Division	Not Applicable
Motor Letter Type	Three Phase
Output @ Frequency	1.500 HP @ 60 HZ
Phase	3
Synchronous Speed @ Frequency	1800 RPM @ 60 HZ
Voltage @ Frequency	230.0 V @ 60 HZ 460.0 V @ 60 HZ
Agency Approvals	CSA EEV NEMA PREMIUM NEMA_PREMIUM UR
Ambient Temperature	40 °C
Auxillary Box	No Auxillary Box
Auxillary Box Lead Termination	None
Base Indicator	Rigid
Bearing Grease Type	Polyrex EM (-20F +300F)
Blower	None
Current @ Voltage	4.640 A @ 208.0 V 4.600 A @ 230.0 V 2.300 A @ 460.0 V
Design Code	B
Drip Cover	No Drip Cover
Duty Rating	CONT
Efficiency @ 100% Load	86.5 %
Electrically Isolated Bearing	Not Electrically Isolated
Feedback Device	NO FEEDBACK
Front Shaft Indicator	None

Part detail

Revision	D
Type	AC
Mech. spec.	05C052
Base	
Status	PRD/A
Elec. spec.	05WGX510
Layout	05LYC052
Eff. date	04-29-2024
CD Diagram	CD0005
Poles	04
Leads	9#18
Proprietary	False
Created date	03-11-2022

Heater Indicator	No Heater
High Voltage Full Load Amps	2.3 a
Insulation Class	F
Inverter Code	Inverter Ready
KVA Code	M
Lifting Lugs	Standard Lifting Lugs
Locked Bearing Indicator	Locked Bearing
Motor Lead Quantity/Wire Size	9 @ 18 AWG
Motor Lead Termination	Flying Leads
Motor Standards	NEMA
Motor Type	0524M
Mounting Arrangement	F1
Number of Poles	4
Overall Length	13.03 IN
Power Factor	72
Product Family	General Purpose
Pulley End Bearing Type	Ball
Pulley Face Code	C-Face
Pulley Shaft Indicator	Standard
Rodent Screen	None
Service Factor	1.15
Shaft Diameter	0.875 IN
Shaft Ground Indicator	No Shaft Grounding
Shaft Rotation	Reversible
Shaft Slinger Indicator	No Slinger
Speed	1770 rpm
Speed Code	Single Speed
Starting Method	Direct on line
Thermal Device - Bearing	None
Thermal Device - Winding	None
Vibration Sensor Indicator	No Vibration Sensor
Winding Thermal 1	None
Winding Thermal 2	None

Nameplate

NP3441LUA

CAT.NO.	CEM3584T						
SPEC	05C052X510G1						
HP	1.5						
VOLTS	230/460						
AMPS	4.34/2.17						
RPM	1760						
FRAME	145TC	HZ	60	PH	3		
SF	1.15	CODE	L	DES	B	CLASS	F
NEMA NOM. EFF	86.5	PF	75				
RATING	40C AMB-CONT						
CC	010A						
ENCL	TEFC	SER					
DE	6205	ODE	6203				
VPWM INVERTER READY	SFA 4.8/2.4						
CT6-60H(10:1)VT3-60H(20:1)	1.5HP 190/380V 50HZ 5.2/2.6A						SF1.0

Parts list

Part number	Description	Quantity
SA407565	SA 05C052X510G1	1.000 ea
RA399064	RA 05C052X510G1	1.000 ea
34FN3002B01	EXTERNAL FAN, PLASTIC, .637/.639 HUB W/	1.000 ea
LB1624	COMBINED WARNING LABEL, ISO/ANSI PICTOGR	1.000 ea
HW3201A05	3/8-16 EYEBOLT	1.000 ea
WD1000B16	T&B CX70TN OR L70P TERMINAL LUG	1.000 ea
10XN2520A06	1/4 20X3/8 HX HD CAP	2.000 ea
06CB3000	BALDOR CONDUIT BOX CAST	1.000 ea
06GS1000	GASKET,CONDUIT BOX	1.000 ea
51XW2520A12	SCREW, HEX SER SLT HD, ZN, 1/4-20 X .75	2.000 ea
11XW1032G06	10-32 X .38, TAPTITE II, HEX WSHR SLTD U	1.000 ea
HW3001B01	BRASS CUP WASHER, FOR #10 SCREW	1.000 ea
35EP1100A02	FR ENDPLATE, TEFC W/GREASER	1.000 ea
HW4500A01	1641B(ALEMITE)400 UNIV, GREASE FITT	1.000 ea
HW5100A03	WAVY WASHER (W1543-017)	1.000 ea
35EP1329A01	PU EP ENCL 143-5TC 205 BRG W/GRSR & STD	1.000 ea
HW4500A01	1641B(ALEMITE)400 UNIV, GREASE FITT	1.000 ea
51XN1032A20	10-32 X 1 1/4 HX WS SL SR	2.000 ea
HA3100A28	THRUBOLT 10-32 X 8.187	4.000 ea
51XB1214A16	12-14X1.00 HXWSSLD SERTYB	1.000 ea
35FH4005A02	IEC FH W/GREASER - W/PRIMER	1.000 ea
51XW1032A06	10-32 X .38, TAPTITE II, HEX WSHR SLTD S	3.000 ea
06CB3500	BALDOR CONDUIT BOX LID	1.000 ea
06GS1001	BALDOR CONDUIT BOX GASKET	1.000 ea
51XW2520A12	.25-20 X .75, TAPTITE II, HEX WSHR SLTD	2.000 ea
HW2501D13	KEY, 3/16 SQ X 1.375	1.000 ea
HA7000A01	KEY RETAINER 7/8" DIA SHAFT	1.000 ea
85XU0407S04	4X1/4 U DRIVE PIN STAINLESS	2.000 ea
MJ1000A02	GREASE, POLYREX EM EXXON	0.050 lb
MG1050Y01	CELEROL BALDOR GOLD *** NLA IN 5 GALLON	0.022 ga
LC0005	CONN.DIA.,TY M,9-LD,DUAL VOLT,REVERSING	1.000 ea

NP3441LUA	AL SUPER-E VPWM INV RDY,UL EEV,NEMA PREM	1.000 ea
36PA1000	PKG GRP, PRINT PK1016A06	1.000 ea
MN416A01	TAG-INSTAL-MAINT no wire (2500bx)4/22	1.000 ea
PE-0000001	ZRTG PE ASSEMBLY	1.000 ea

AC Induction Motor Performance Data

Record # 95408

Typical performance - not guaranteed values

Winding: 05WGX510-R001		Type: 0524M		Enclosure: TEFC	
Nameplate Data			460 V, 60 Hz: High Voltage Connection		
Rated Output (HP)	1.5	Full Load Torque	4.48 LB-FT		
Volts	230/460	Start Configuration	direct on line		
Full Load Amps	4.6/2.3	Breakdown Torque	18.8 LB-FT		
R.P.M.	1770	Pull-up Torque	9.6 LB-FT		
Hz	60 Phase	3	Locked-rotor Torque	12.6 LB-FT	
NEMA Design Code	B KVA Code	M	Starting Current	19.7 A	
Service Factor (S.F.)	1.15	No-load Current	1.51 A		
NEMA Nom. Eff.	86.5 Power Factor	72	Line-line Res. @ 25°C	11.8 Ω	
Rating - Duty	40C AMB-CONT	Temp. Rise @ Rated Load	48°C		
S.F. Amps	5/2.5	Temp. Rise @ S.F. Load	57°C		
		Locked-rotor Power Factor	58.4		
		Rotor inertia	0.173 lb-ft ²		

Load Characteristics 460 V, 60 Hz, 1.5 HP

% of Rated Load	25	50	75	100	125	150	S.F.
Power Factor	31	49	63	72	78	81	76
Efficiency	75.1	83.5	86	86.5	85.8	84.8	86.1
Speed	1792	1785	1777	1769	1760	1750	1764
Line amperes	1.56	1.72	1.97	2.28	2.65	3.06	2.5

ABB Motors and Mechanical Inc.

WINDING # 05WGX510

Typical performance - not guaranteed values.

1.5 HP 3 PH 60 HZ 1770 RPM 460 V 0524M

TORQUES (LB-FT): PO=18.8 PU=9.6 LR=12.6 LRA=19.7

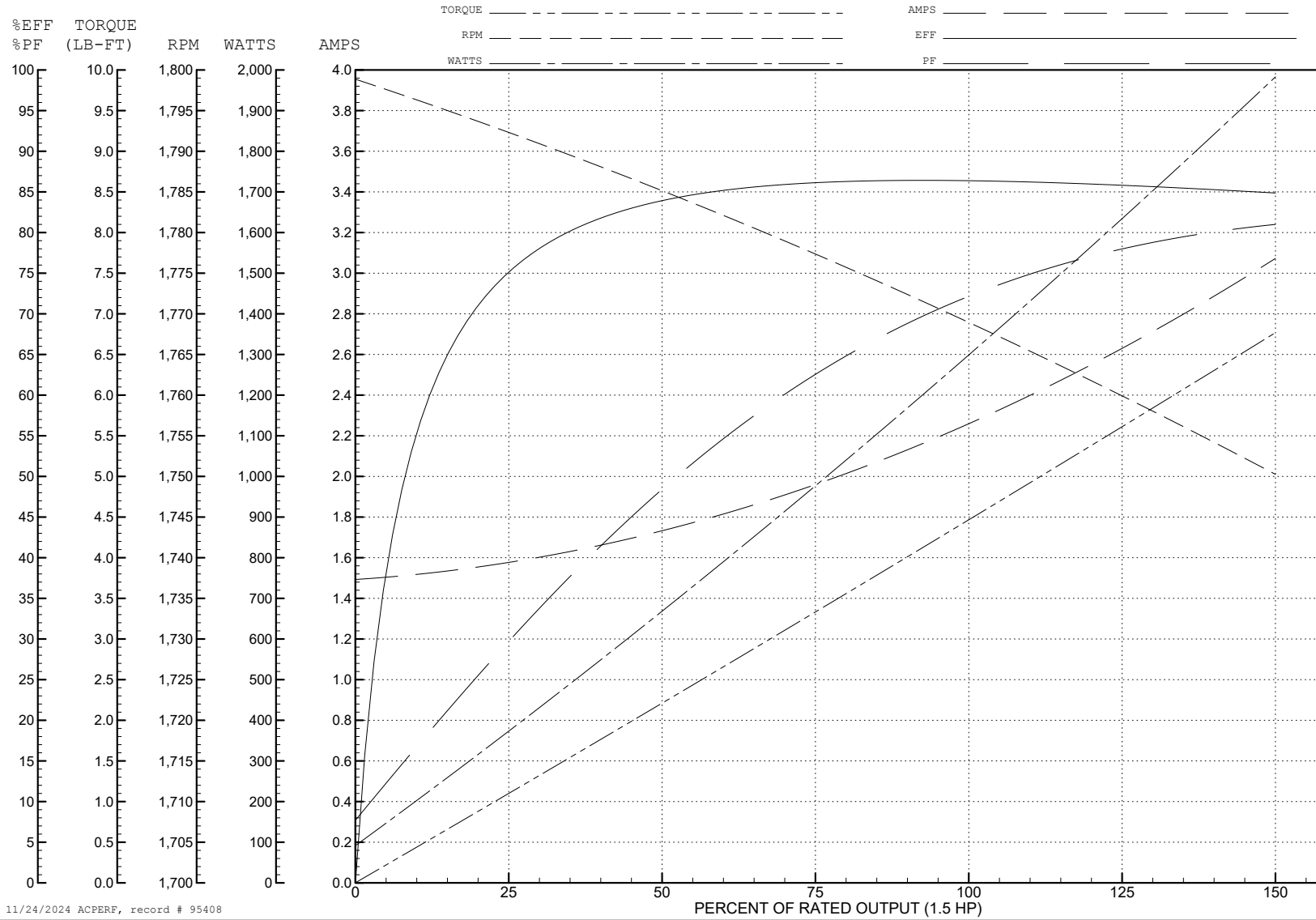

11/24/2024 ACPERF, record # 95408

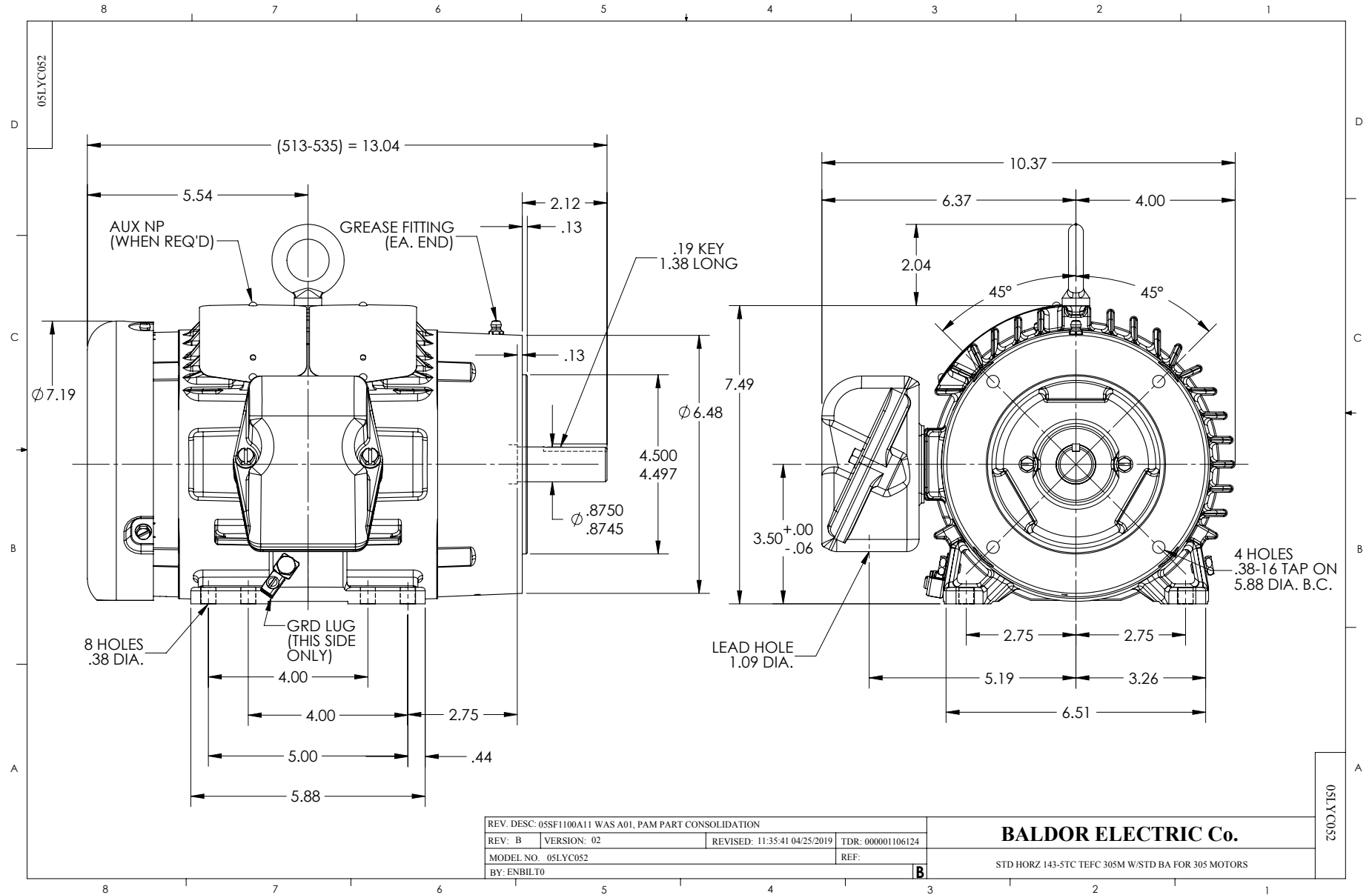

CD0005

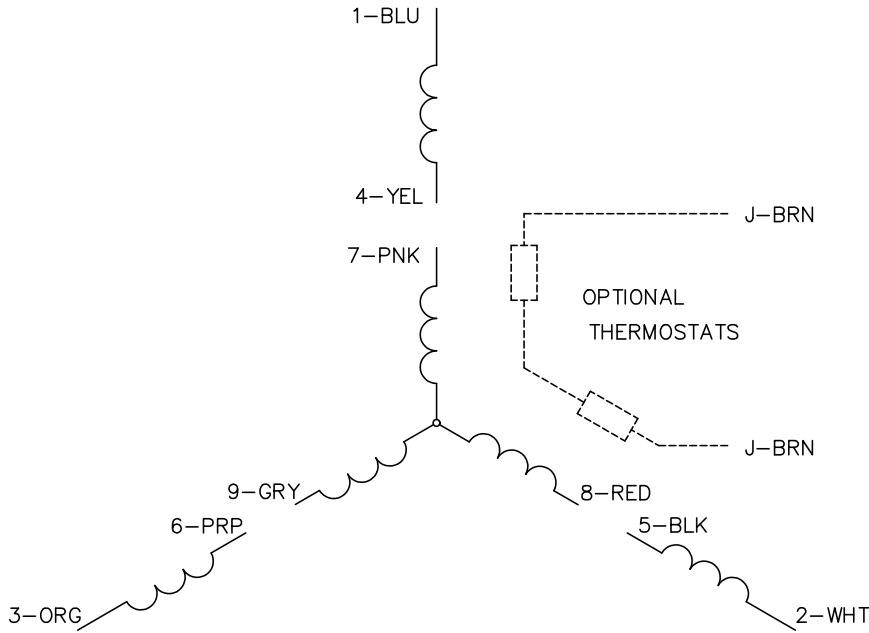

LOW VOLTAGE
(2Y)

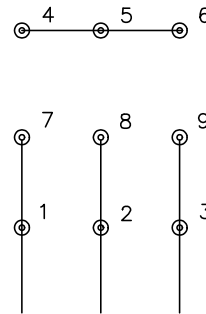

LINE

HIGH VOLTAGE
(1Y)

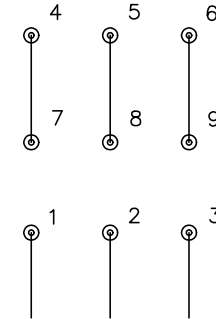

LINE

NOTES:

1. INTERCHANGE ANY TWO LINE LEADS TO REVERSE ROTATION.
2. OPTIONAL THERMOSTATS ARE PROVIDED WHEN SPECIFIED.
3. ACTUAL NUMBER OF INTERNAL PARALLEL CIRCUITS MAY BE A MULTIPLE OF THOSE SHOWN ABOVE.
4. LEAD COLORS ARE OPTIONAL. LEADS MUST ALWAYS BE NUMBERED AS SHOWN.

CD0005

REV. DESC: REVISE TO SHOW OPTIONAL COLORS			
REV. LTR: E	BY: JLP	REVISED: 01/19/99 10:15	TDR: 0171435
S00000		FILE: AAA00005140	MDL: -
		MTL: -	

BALDOR ELECTRIC Co.

3PH, DV, 9 LEADS