

BALDOR • RELIANCE

Customer information packet

CESSWDM3550-5

1.5HP, 3450RPM, 3PH, 60HZ, 56C, 3532M, TENV, F1

Class -

Division - Not Applicable

Specifications

Enclosure	TENV
Frame	56C
Frame Material	Stainless Steel
Frequency	60.00 Hz
Haz Area Division	Not Applicable
Motor Letter Type	Three Phase
Output @ Frequency	1.500 HP @ 60 HZ
Phase	3
Synchronous Speed @ Frequency	3600 RPM @ 60 HZ
Voltage @ Frequency	575.0 V @ 60 HZ
Ambient Temperature	40 °C
Auxillary Box	No Auxillary Box
Auxillary Box Lead Termination	None
Base Indicator	Rigid
Bearing Grease Type	Polyrex EM (-20F +300F)
Blower	None
Current @ Voltage	1.500 A @ 575.0 V
Design Code	B
Drip Cover	No Drip Cover
Duty Rating	CONT
Efficiency @ 100% Load	85.5 %
Electrically Isolated Bearing	Not Electrically Isolated
Feedback Device	NO FEEDBACK
Front Face Code	Standard
Front Shaft Indicator	None
Heater Indicator	No Heater
High Voltage Full Load Amps	1.5 a
Insulation Class	F
Inverter Code	Inverter Ready
KVA Code	M
Lifting Lugs	No Lifting Lugs
Locked Bearing Indicator	Locked Bearing

Part detail

Revision	F
Type	AC
Mech. spec.	35V814
Base	
Status	PRD/A
Elec. spec.	35WGL024
Layout	35LYV814
Eff. date	09-22-2023
CD Diagram	CD0006
Poles	02
Leads	3#18
Proprietary	False
Created date	11-22-2017

Motor Lead Exit	Ko Box
Motor Lead Quantity/Wire Size	3 @ 18 AWG
Motor Lead Termination	Flying Leads
Motor Standards	NEMA
Motor Type	3532M
Mounting Arrangement	F1
Number of Poles	2
Overall Length	12.97 IN
Power Factor	92
Product Family	Wash Down All Stainless Steel
Pulley End Bearing Type	Sealed Bearing
Pulley Face Code	C-Face
Pulley Shaft Indicator	Standard
Rodent Screen	None
RoHS Status	ROHS COMPLIANT
Service Factor	1.15
Shaft Diameter	0.625 IN
Shaft Extension Location	Pulley End
Shaft Ground Indicator	No Shaft Grounding
Shaft Rotation	Reversible
Shaft Slinger Indicator	No Slinger
Speed	3450 rpm
Speed Code	Single Speed
Starting Method	Direct on line
Thermal Device - Bearing	None
Thermal Device - Winding	None
Vibration Sensor Indicator	No Vibration Sensor
Winding Thermal 1	None
Winding Thermal 2	None

Nameplate

NP1953A05									
CAT.NO.	CESSWDM3550-5								
SPEC.	35V814L024G1								
HP	1.5								
VOLTS	575								
AMP	1.5								
RPM	3450								
FRAME	56C		HZ	60		PH	3		
SER.F.	1.15	CODE	M	DES	B	CLASS	F		
NEMA-NOM-EFF	85.5	PF	92						
RATING	40C AMB-CONT								
CC		USABLE AT 208V					N/A		
DE	6205	ODE	6203						
ENCL	TENV	SN							
	4:1CT 20:1VT								

Parts list

Part number	Description	Quantity
SA351987	SA 35V814L024G1	1.000 ea
RA340717	RA 35V814L024G1	1.000 ea
NS2512A01	INSULATOR, CONDUIT BOX X	1.000 ea
35CB5001A08	CONDUIT BOX KIT, S/P 9-2 (ALL STAINLESS)	1.000 ea
HA5027A02	HA4054 T-DRAIN X2 BAGGED WITH LABEL	1.000 ea
11XW1032G06	10-32 X .38, TAPTITE II, HEX WSHR SLTD U	1.000 ea
HW3001B01	BRASS CUP WASHER, FOR #10 SCREW	1.000 ea
35EP1913A01	FRONT TENV 203 BRG NO GRSSR S/P 9-2 (STAI	1.000 ea
HW4500S33	1/8 NPT STAINLESS #304 SS PLUG	3.000 ea
HW5100A03	WAVY WASHER (W1543-017)	1.000 ea
35EP1914A02	PU EP FOR LOCKED 6205 BRG	1.000 ea
HW4500S33	1/8 NPT STAINLESS #304 SS PLUG	3.000 ea
HW4606A02	JM CLIPPER/SEAL (LWE-0938-1624-AL23)	1.000 ea
12XN1032S22	10-32 X 1 3/8 SLOT HEX, STAINLESS STEEL	2.000 ea
HA1049A01	DUBO LOK WASHER SIZE 10 (NYLON LOCK SEAL	2.000 ea
HA1049A01	DUBO LOK WASHER SIZE 10 (NYLON LOCK SEAL	4.000 ea
HW2502D13	SS KEY, 3/16 SQ X 1.375	1.000 ea
HA7000A04	KEY RETAINER 0.625 DIA SHAFTS	1.000 ea
MJ5001A02	732 CL SEALANT 3 OZ DIXIE BEARING 289100	0.001 ea
MJ1000A02	GREASE, POLYREX EM EXXON	0.050 lb
HA3100S19	THRUBOLT, 10X32 - 9.812 SS	4.000 ea
MN416A01	TAG-INSTAL-MAINT no wire (2500bx)4/22	1.000 ea
36PA1000	PKG GRP, PRINT PK1016A06	1.000 ea
FE-0000007	ZRTG FE ASSEMBLY	1.000 ea
PE-0000012	ZRTG PE ASSEMBLY	1.000 ea

AC Induction Motor Performance Data

Record # 50216

Typical performance - not guaranteed values

Winding: 35WGL024-R003		Type: 3532M	Enclosure: TENV	
Nameplate Data			575 V, 60 Hz: Single Voltage Motor	
Rated Output (HP)	1.5	Full Load Torque	2.31 LB-FT	
Volts	575	Start Configuration	direct on line	
Full Load Amps	1.5	Breakdown Torque	11 LB-FT	
R.P.M.	3450	Pull-up Torque	5.23 LB-FT	
Hz	60 Phase	3	Locked-rotor Torque	10.3 LB-FT
NEMA Design Code	B KVA Code	M	Starting Current	16.6 A
Service Factor (S.F.)		1.15	No-load Current	0.559 A
NEMA Nom. Eff.	85.5 Power Factor	92	Line-line Res. @ 25°C	12.1 Ω
Rating - Duty	40C AMB-CONT		Temp. Rise @ Rated Load	
			Locked-rotor Power Factor	45.8
			Rotor inertia	0.0885 LB-FT ²

Load Characteristics 575 V, 60 Hz, 1.5 HP

% of Rated Load	25	50	75	100	125	150	S.F.
Power Factor	55	77	85	92	92	90	92
Efficiency	73.8	82.3	85.3	86.2	85.9	85.5	86
Speed	3564	3536	3508	3477	3445	3407	3458
Line amperes	0.73	0.921	1.19	1.45	1.79	2.2	1.65

ABB Motors and Mechanical Inc.

WINDING # 35WGL024

1.5 HP 3 PH 60 HZ 3450 RPM 575 V 3532M

Typical performance - not guaranteed values.

TORQUES (LB-FT): PO=11 PU=5.23 LR=10.3 LRA=16.6

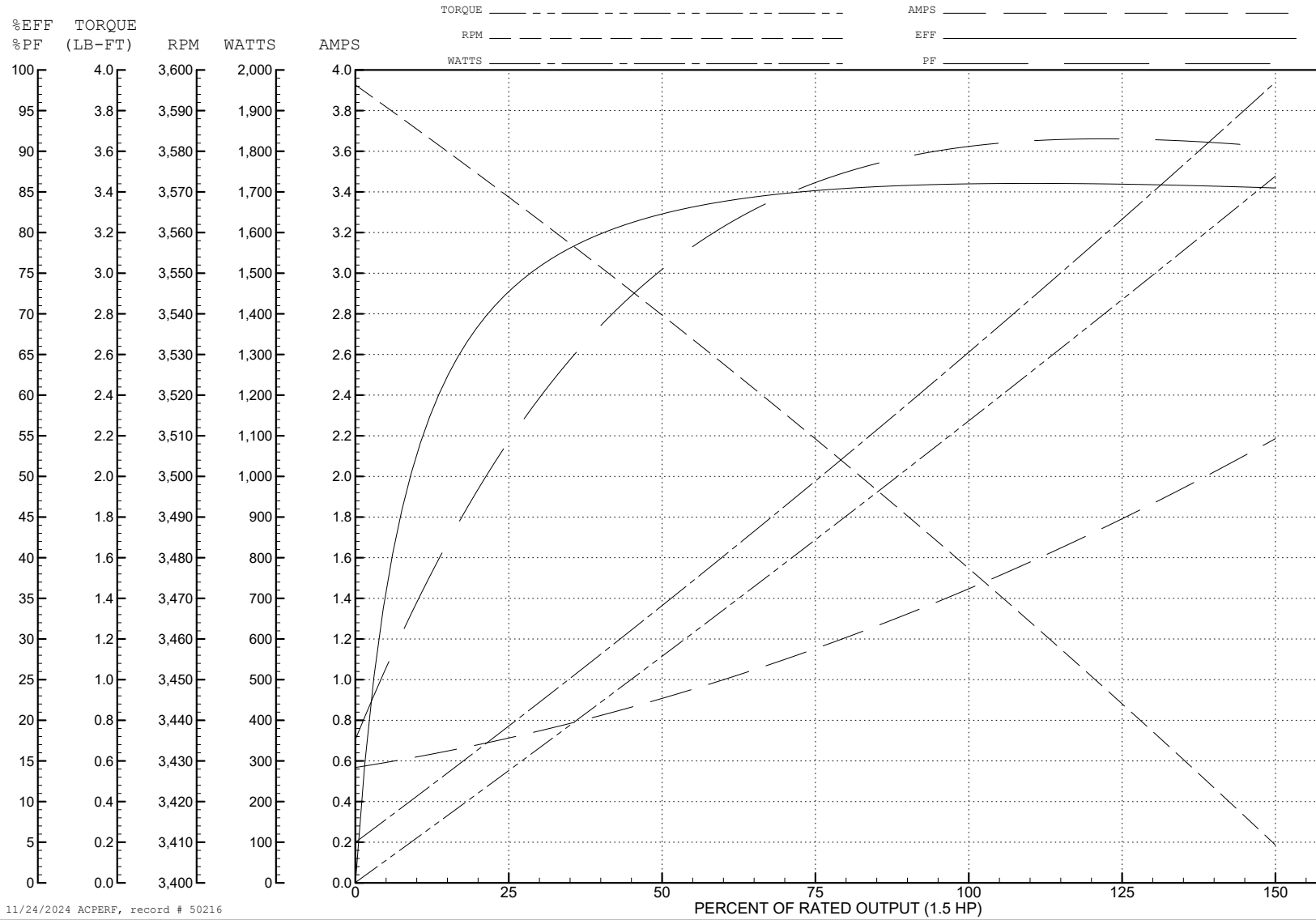

11/24/2024 ACPERF, record # 50216

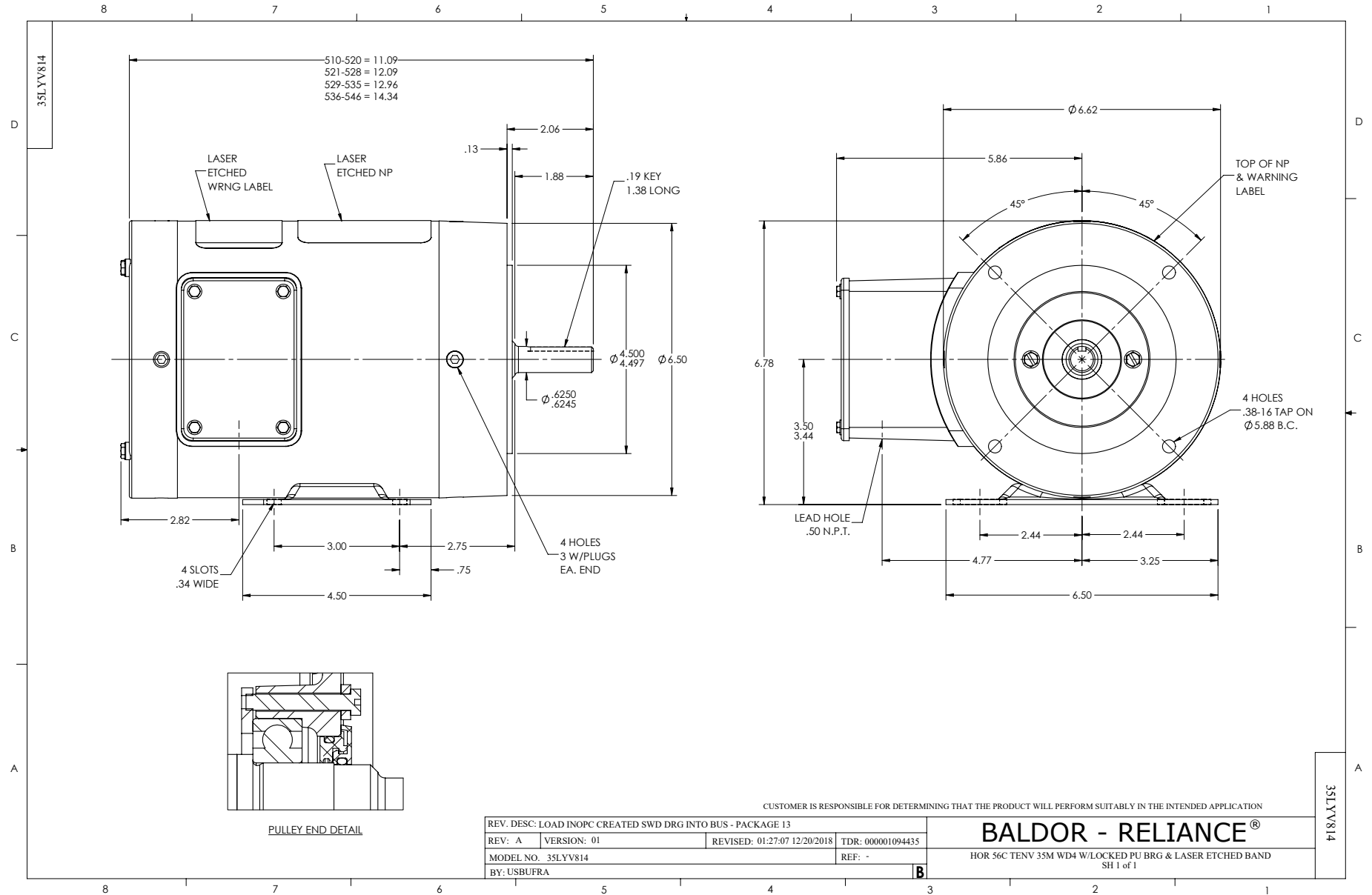

CD0006

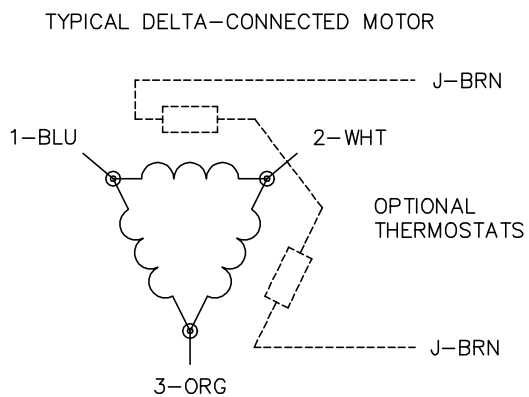
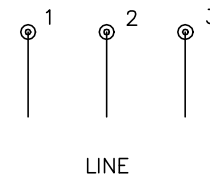
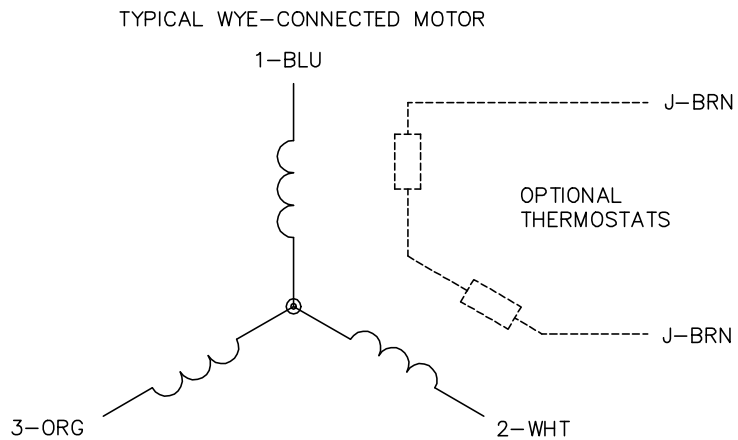

NOTES:

1. THREE LEAD MOTOR MAY BE EITHER WYE CONNECTED OR DELTA CONNECTED.
2. INTERCHANGE ANY TWO LINE LEADS TO REVERSE ROTATION.
3. OPTIONAL THERMOSTATS ARE PROVIDED WHEN SPECIFIED.
4. ACTUAL NUMBER OF INTERNAL PARALLEL CIRCUITS MAY VARY.
5. LEAD COLORS ARE OPTIONAL. LEADS MUST BE NUMBERED AS SHOWN.

CD0006

REV. DESC: ADD CLASS CONN00000007		
REV. LTR: E	VERSION: 01	TDR: 000001099922
FILE: \AAA\00005\141	REVISED: 10:24:49 02/19/2019	BY: ENBRIRO
MTL: -	© □	

BALDOR - RELIANCE®

3PH, SV, 3 LEADS, WYE OR DELTA CONNECTED

SH 1 of 1