



Customer information packet

CESSWDM3559T-5

3HP, 3470RPM, 3PH, 60HZ, 145TC, 3546M, TEFC, F1

Class - None

Division - Not Applicable

Specifications

Enclosure	TEFC
Frame	145TC
Frame Material	Stainless Steel
Frequency	60.00 Hz
Haz Area Class and Group	None
Haz Area Division	Not Applicable
Motor Letter Type	Three Phase
Output @ Frequency	3.000 HP @ 60 HZ
Phase	3
Synchronous Speed @ Frequency	3600 RPM @ 60 HZ
Voltage @ Frequency	575.0 V @ 60 HZ
Agency Approvals	UR CSA
Ambient Temperature	40 °C
Auxillary Box	No Auxillary Box
Auxillary Box Lead Termination	None
Base Indicator	Rigid
Bearing Grease Type	Polyrex EM (-20F +300F)
Blower	None
Current @ Voltage	2.900 A @ 575.0 V
Design Code	A
Drip Cover	No Drip Cover
Duty Rating	CONT
Efficiency @ 100% Load	86.5 %
Electrically Isolated Bearing	Not Electrically Isolated
Feedback Device	NO FEEDBACK
Front Face Code	Standard
Front Shaft Indicator	None
Heater Indicator	No Heater
High Voltage Full Load Amps	2.9 a
Insulation Class	F
Inverter Code	Inverter Ready

Part detail

Revision	T
Type	AC
Mech. spec.	35VV818
Base	
Status	PRD/A
Elec. spec.	35WGN653
Layout	35LYVV818
Eff. date	02-19-2024
CD Diagram	CD0006
Poles	02
Leads	3#18
Proprietary	False
Created date	02-07-2013

KVA Code	P
Lifting Lugs	No Lifting Lugs
Locked Bearing Indicator	Locked Bearing
Motor Lead Exit	Ko Box
Motor Lead Quantity/Wire Size	3 @ 18 AWG
Motor Lead Termination	Flying Leads
Motor Standards	NEMA
Motor Type	3546M
Mounting Arrangement	F1
Number of Poles	2
Overall Length	15.67 IN
Power Factor	91
Product Family	Wash Down All Stainless Steel
Pulley End Bearing Type	Sealed Bearing
Pulley Face Code	C-Face
Pulley Shaft Indicator	Standard
Rodent Screen	None
RoHS Status	ROHS COMPLIANT
Service Factor	1.15
Shaft Diameter	0.875 IN
Shaft Extension Location	Pulley End
Shaft Ground Indicator	No Shaft Grounding
Shaft Rotation	Reversible
Shaft Slinger Indicator	No Slinger
Speed	3470 rpm
Speed Code	Single Speed
Starting Method	Direct on line
Thermal Device - Bearing	None
Thermal Device - Winding	None
Vibration Sensor Indicator	No Vibration Sensor
Winding Thermal 1	None
Winding Thermal 2	None

Nameplate

NP1951A05									
CAT.NO.	CESSWDM3559T-5								
SPEC.	35VV818N653G1								
HP	3								
VOLTS	575								
AMP	2.9								
RPM	3470								
FRAME	145TC		HZ	60		PH	3		
SER.F.	1.15	CODE	P	DES	A	CLASS	F		
NEMA-NOM-EFF	86.5	PF	91						
RATING	40C AMB-CONT								
CC	010A								
DE	6205	ODE	6203						
ENCL	TEFC	SN							
	4:1CT 20:1VT								

Parts list

Part number	Description	Quantity
SA258172	SA 35VV818N653G1	1.000 ea
RA244948	RA 35VV818N653G1	1.000 ea
34FN3002A01SP	EXTERNAL FAN, PLASTIC, .637/.639 HUB W/	1.000 ea
NS2512A01	INSULATOR, CONDUIT BOX X	1.000 ea
35CB5001A17	KOBX KIT, (ALL STAINLESS) W/ .75 NPT	1.000 ea
HA5027A02	HA4054 T-DRAIN X2 BAGGED WITH LABEL	1.000 ea
11XW1032G06	10-32 X .38, TAPTITE II, HEX WSHR SLTD U	1.000 ea
HW3001B01	BRASS CUP WASHER, FOR #10 SCREW	1.000 ea
35EP1913A02	FR EP MADE FROM 35EP1913A01	1.000 ea
HW4500S33	1/8 NPT STAINLESS #304 SS PLUG	3.000 ea
HW4606A01	JM CLIPPER/SEAL (WDE-0667-1064-BH49)	1.000 ea
HW5100A03	WAVY WASHER (W1543-017)	1.000 ea
35EP1914A02	PU EP FOR LOCKED 6205 BRG	1.000 ea
HW4500S33	1/8 NPT STAINLESS #304 SS PLUG	3.000 ea
HW4606A02	JM CLIPPER/SEAL (LWE-0938-1624-AL23)	1.000 ea
12XN1032S22	10-32 X 1 3/8 SLOT HEX, STAINLESS STEEL	2.000 ea
HA1049A01	DUBO LOK WASHER SIZE 10 (NYLON LOCK SEAL	2.000 ea
HA1049A01	DUBO LOK WASHER SIZE 10 (NYLON LOCK SEAL	4.000 ea
51XB1214A16	12-14X1.00 HXWSSLD SERTYB	1.000 ea
35FH4005A39	IEC FH NO GREASER DEBURR/CLEAN - SS	1.000 ea
10XN1032S06	HEX HD CAP SCREW, SS	3.000 ea
HW2502D13	SS KEY, 3/16 SQ X 1.375	1.000 ea
HA7000A01	KEY RETAINER 7/8" DIA SHAFT	1.000 ea
MJ5001A02	732 CL SEALANT 3 OZ DIXIE BEARING 289100	0.001 ea
HW3001B01	BRASS CUP WASHER, FOR #10 SCREW	1.000 ea
MJ1000A02	GREASE, POLYREX EM EXXON	0.050 lb
HA3100S04	THRUBOLT- 10-32 X 11.250 302 OR 303 SS	4.000 ea
36PA1000	PKG GRP, PRINT PK1016A06	1.000 ea
MN416A01	TAG-INSTAL-MAINT no wire (2500bx)4/22	1.000 ea
FE-0000007	ZRTG FE ASSEMBLY	1.000 ea
PE-0000012	ZRTG PE ASSEMBLY	1.000 ea

AC Induction Motor Performance Data

Record # 50291

Typical performance - not guaranteed values

Winding: 35WGN653-R002		Type: 3546M		Enclosure: TEFC	
Nameplate Data			575 V, 60 Hz: Single Voltage Motor		
Rated Output (HP)		3	Full Load Torque		4.5 LB-FT
Volts		575	Start Configuration		direct on line
Full Load Amps		2.9	Breakdown Torque		17.5 LB-FT
R.P.M.		3470	Pull-up Torque		10.7 LB-FT
Hz	60	Phase	3	Locked-rotor Torque	17.3 LB-FT
NEMA Design Code	A	KVA Code	P	Starting Current	39.4 A
Service Factor (S.F.)		1.15	No-load Current		1.02 A
NEMA Nom. Eff.	86.5	Power Factor	91	Line-line Res. @ 25°C	5.41 Ω
Rating - Duty		40C	AMB-CONT	Temp. Rise @ Rated Load	63°C
S.F. Amps				Temp. Rise @ S.F. Load	74°C
				Locked-rotor Power Factor	42.7
				Rotor inertia	0.127 LB-FT ²

Load Characteristics 575 V, 60 Hz, 3 HP

% of Rated Load	25	50	75	100	125	150	S.F.
Power Factor	58	79	87	90	91	90	91
Efficiency	79.3	86.2	87	86.9	85.6	83.9	86.1
Speed	3568	3542	3511	3481	3446	3406	3460
Line amperes	1.24	1.67	2.24	2.85	3.54	4.32	3.26

ABB Motors and Mechanical Inc.

WINDING # 35WGN653

3 HP 3 PH 60 HZ 3470 RPM 575 V 3546M

Typical performance - not guaranteed values.

TORQUES (LB-FT): PO=17.5 PU=10.7 LR=17.3 LRA=39.4

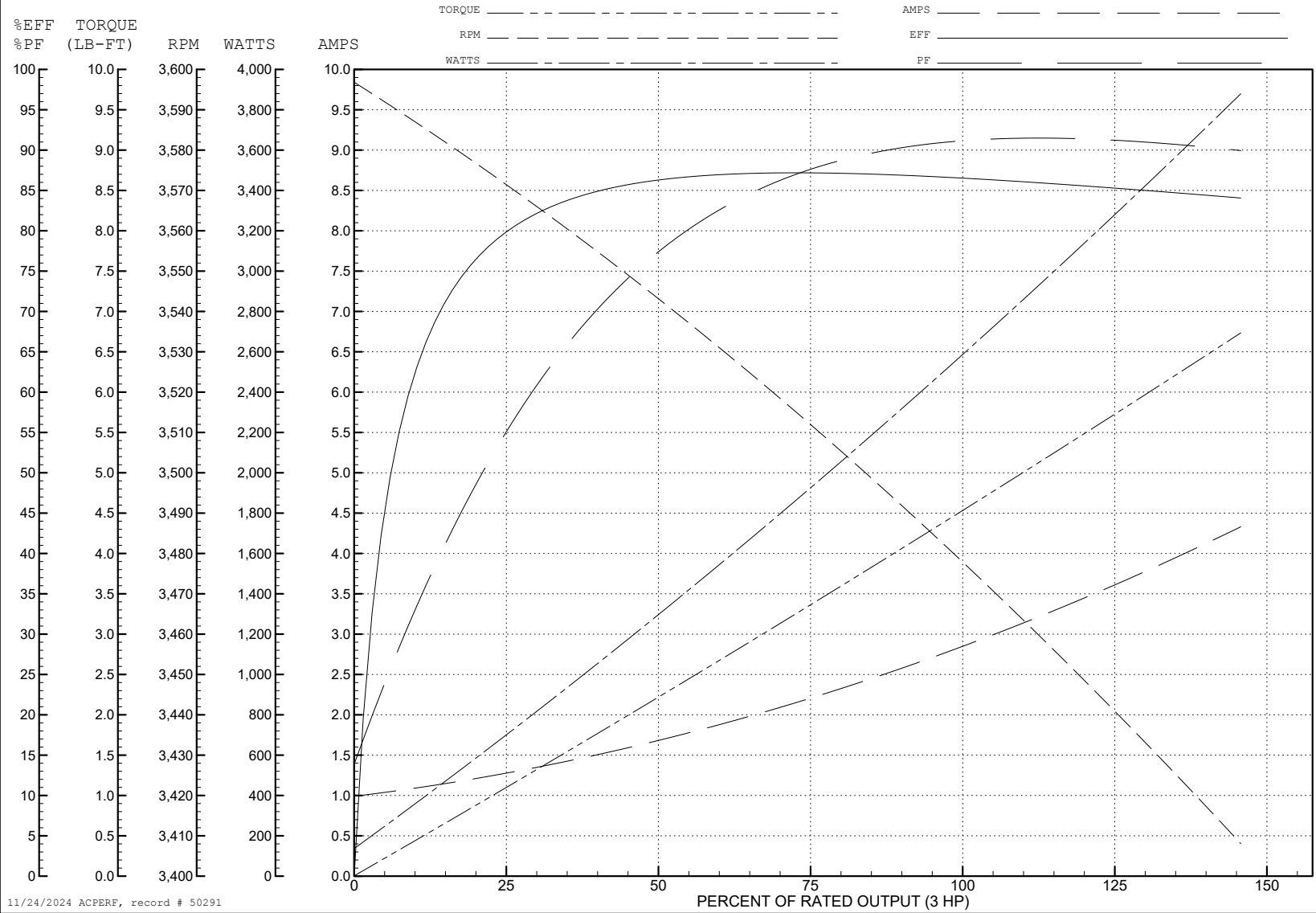

11/24/2024 ACPERF, record # 50291

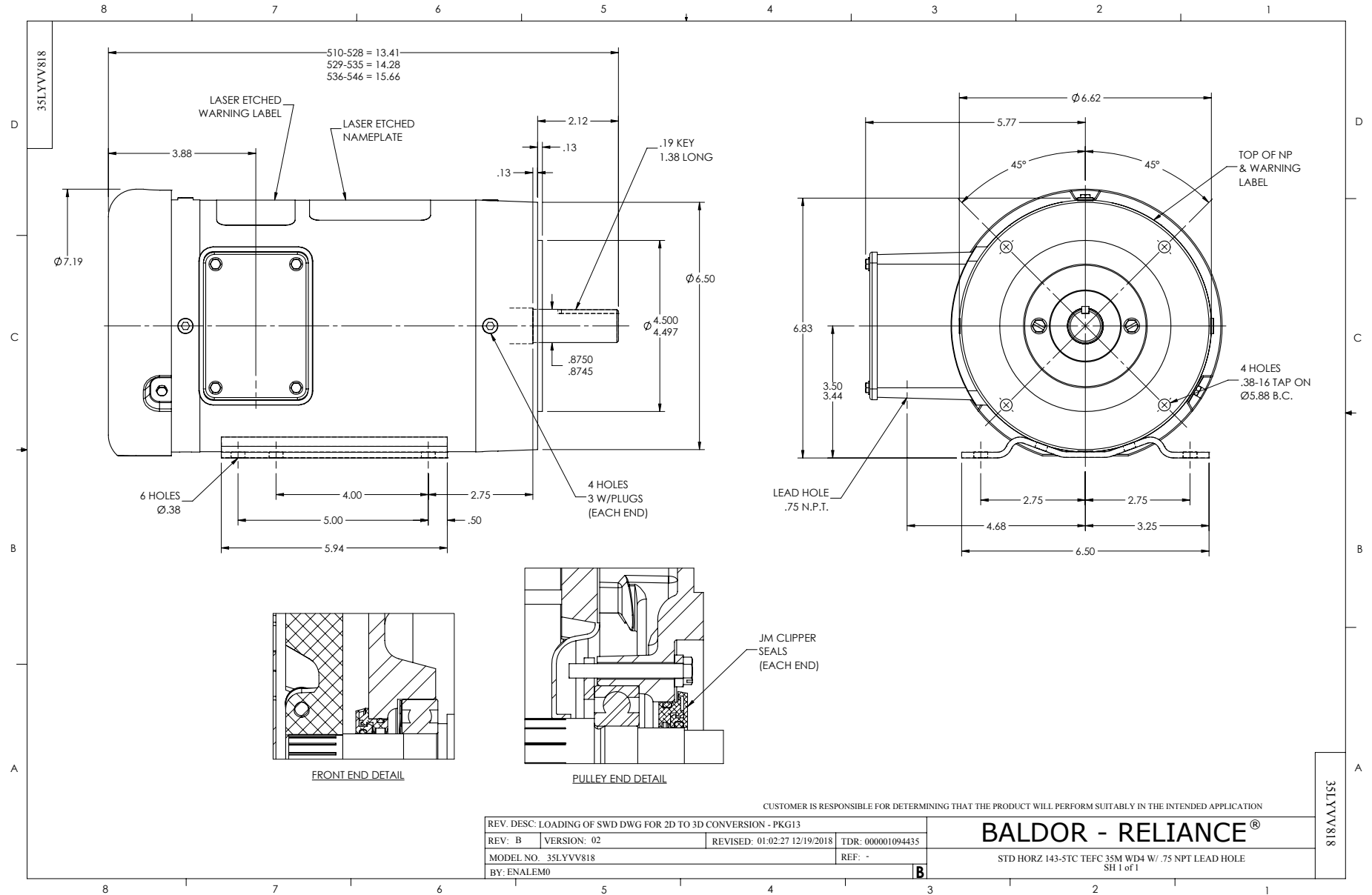

CD0006

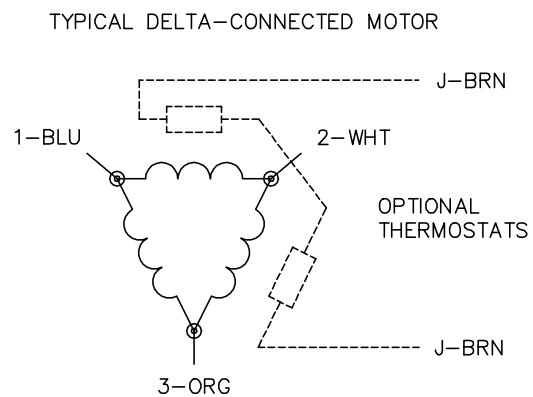
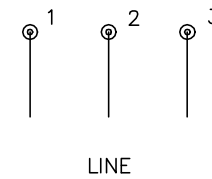
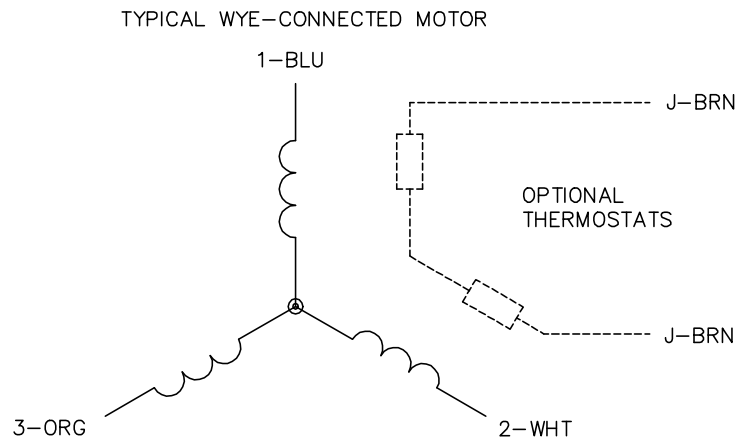

NOTES:

1. THREE LEAD MOTOR MAY BE EITHER WYE CONNECTED OR DELTA CONNECTED.
2. INTERCHANGE ANY TWO LINE LEADS TO REVERSE ROTATION.
3. OPTIONAL THERMOSTATS ARE PROVIDED WHEN SPECIFIED.
4. ACTUAL NUMBER OF INTERNAL PARALLEL CIRCUITS MAY VARY.
5. LEAD COLORS ARE OPTIONAL. LEADS MUST BE NUMBERED AS SHOWN.

CD0006

REV. DESC: ADD CLASS CONN00000007		
REV. LTR: E	VERSION: 01	TDR: 000001099922
FILE: \AAA\00005\141	REVISED: 10:24:49 02/19/2019	BY: ENBRIRO
MTL: -	© □	

BALDOR - RELIANCE®

3PH, SV, 3 LEADS, WYE OR DELTA CONNECTED

SH 1 of 1