



Customer information packet

CEWDM3546T-5

1HP, 1770RPM, 3PH, 60HZ, 143TC, 3522M, TENV, F1

Class - None

Division - Not Applicable

Specifications

Enclosure	TENV
Frame	143TC
Frame Material	Steel
Frequency	60.00 Hz
Haz Area Class and Group	None
Haz Area Division	Not Applicable
Motor Letter Type	Three Phase
Output @ Frequency	1.000 HP @ 60 HZ
Phase	3
Synchronous Speed @ Frequency	1800 RPM @ 60 HZ
Voltage @ Frequency	575.0 V @ 60 HZ
Agency Approvals	NEMA PREMIUM NEMA_PREMIUM UR CSA EEV
Ambient Temperature	40 °C
Auxillary Box	No Auxillary Box
Auxillary Box Lead Termination	None
Base Indicator	Rigid
Bearing Grease Type	Polyrex EM (-20F +300F)
Blower	None
Current @ Voltage	1.300 A @ 575.0 V
Design Code	B
Drip Cover	No Drip Cover
Duty Rating	CONT
Efficiency @ 100% Load	85.5 %
Electrically Isolated Bearing	Not Electrically Isolated
Feedback Device	NO FEEDBACK
Front Shaft Indicator	None
Heater Indicator	No Heater
High Voltage Full Load Amps	1.3 a
Insulation Class	F

Part detail

Revision	B
Type	AC
Mech. spec.	35SS592
Base	
Status	PRD/A
Elec. spec.	35WGG198
Layout	35LYSS592
Eff. date	02-14-2024
CD Diagram	CD0006
Poles	04
Leads	3#18
Proprietary	False
Created date	03-11-2022

Inverter Code	Inverter Ready
KVA Code	N
Lifting Lugs	No Lifting Lugs
Locked Bearing Indicator	Locked Bearing
Motor Lead Quantity/Wire Size	3 @ 18 AWG
Motor Lead Termination	Flying Leads
Motor Standards	NEMA
Motor Type	3522M
Mounting Arrangement	F1
Number of Poles	4
Overall Length	12.12 IN
Power Factor	67
Product Family	Wash Down
Pulley End Bearing Type	Sealed Bearing
Pulley Face Code	C-Face
Pulley Shaft Indicator	Standard
Rodent Screen	None
Service Factor	1.15
Shaft Diameter	0.875 IN
Shaft Ground Indicator	No Shaft Grounding
Shaft Rotation	Reversible
Shaft Slinger Indicator	No Slinger
Speed	1770 rpm
Speed Code	Single Speed
Starting Method	Direct on line
Thermal Device - Bearing	None
Thermal Device - Winding	None
Vibration Sensor Indicator	No Vibration Sensor
Winding Thermal 1	None
Winding Thermal 2	None

Nameplate

NP1669L									
CAT.NO.	CEWDM3546T-5								
SPEC.	35SS592G198G1								
HP	1								
VOLTS	575								
AMP	1.3								
RPM	1775								
FRAME	143TC		HZ	60		PH	3		
SER.F.	1.15	CODE	M	DES	B	CLASS	F		
NEMA-NOM-EFF	85.5	PF	70						
RATING	40C AMB-CONT								
CC	010A								
DE	6205		ODE	6203					
ENCL	TENV	SN							
BLANK	SFA 1.4								

Parts list

Part number	Description	Quantity
SA409109	SA 35SS592G198G1	1.000 ea
RA400655	RA 35SS592G198G1	1.000 ea
35FN3002A05SP	EXFN, PLASTIC, 6.376 OD, .638 ID	1.000 ea
35CB3010A01G	35 CB .75 NPT @ 6:00 (GRAY)	1.000 ea
NS2512A01	INSULATOR, CONDUIT BOX X	1.000 ea
35GS1039	05 MOLDED GASKET W/LIP, 1.12 LEAD HOLE,	1.000 ea
51XB1016A08	10-16X 1/2HXWSSLD SERTYB	2.000 ea
11XW1032G06	10-32 X .38, TAPTITE II, HEX WSHR SLTD U	1.000 ea
35EP3122D00W	MASTER ODE,203 BRG,.125NPT DRNS(WHITE)	1.000 ea
HW4072A01	BLACK DRAIN PLUG FOR .125 NPT	3.000 ea
HW5100A03	WAVY WASHER (W1543-017)	1.000 ea
35EP3307E00W	MASTER DE,205 BRG,1.623SH,.125NPT DRNS,C	1.000 ea
HW4072A01	BLACK DRAIN PLUG FOR .125 NPT	3.000 ea
12XN1032S20	10-32 X 1-1/4 HEX M.S. , STAINLESS STEEL	2.000 ea
HW4600B49	SEAL 0.938 X 1.624 X 0.250 SINGLE LIP DB	1.000 ea
35CB4522	35 LIPPED CB LID PRIMED	1.000 ea
35GS1030A02	35 GS FOR CB LID - WHITE NEOPRENE	1.000 ea
59XW0832S07	TAPTITE II,HEX WSHR UNSLTD SER,410 S.S.,	4.000 ea
HW4600B46	V-RING SLINGER 0.875 X 1.420 X .24 VITON	1.000 ea
HW2502D13	SS KEY, 3/16 SQ X 1.375	1.000 ea
HA7000A01	KEY RETAINER 7/8" DIA SHAFT	1.000 ea
MJ5001A27	32220KN GRAY SEALER *MIN BUY 4 QTS=1GAL	0.001 qt
85XU0407S04	4X1/4 U DRIVE PIN STAINLESS	2.000 ea
LB1164	LABEL,WARNING AND DRAIN	1.000 ea
HA5027A02	HA4054 T-DRAIN X2 BAGGED WITH LABEL	1.000 ea
MJ1000A02	GREASE, POLYREX EM EXXON	0.050 lb
MG1025Z02	ACTIVATOR WILKOFASST 060.02HF	0.010 ga
MG1025W01	WILKOFASST, 781.01, SIGNAL WHITE #9003	0.017 ga
HA3100S07	THRUBOLT 10-32 X 8.375 SS	4.000 ea
LC0006	CONNECTION LABEL	1.000 ea
NP1669L	SS WD SUPER-E UL PREM REV MTG	1.000 ea

35PA1066	PKG GRP, PRINT PK1008A06	1.000 ea
MN416A01	TAG-INSTAL-MAINT no wire (2500bx)4/22	1.000 ea
FE-0000001	ZRTG FE ASSEMBLY	1.000 ea
PE-0000002	ZRTG PE ASSEMBLY	1.000 ea

AC Induction Motor Performance Data

Record # 82151

Typical performance - not guaranteed values

Winding: 35WGG198-R001		Type: 3522M		Enclosure: TEFC	
Nameplate Data			575 V, 60 Hz: Single Voltage Motor		
Rated Output (HP)	1	Full Load Torque	2.99 LB-FT		
Volts	575	Start Configuration	direct on line		
Full Load Amps	1.3	Breakdown Torque	16.37 LB-FT		
R.P.M.	1770	Pull-up Torque	7.31 LB-FT		
Hz	60	Locked-rotor Torque	10.16 LB-FT		
NEMA Design Code	B	Starting Current	12.72 A		
Service Factor (S.F.)	1.15	No-load Current	0.972 A		
NEMA Nom. Eff.	85.5	Line-line Res. @ 25°C	22.9 Ω		
Rating - Duty	40C	Temp. Rise @ Rated Load	63°C		
S.F. Amps	1.4	Temp. Rise @ S.F. Load	71°C		
		Locked-rotor Power Factor	59.6		
		Rotor inertia	0.159 lb-ft ²		

Load Characteristics 575 V, 60 Hz, 1 HP

% of Rated Load	25	50	75	100	125	150	S.F.
Power Factor	28	44	56	67	73	78	71
Efficiency	71.2	81.2	84.4	86	85.7	85.1	85.8
Speed	1793	1786	1781	1773	1766	1757	1769
Line amperes	0.988	1.06	1.18	1.32	1.49	1.69	1.42

ABB Motors and Mechanical Inc.

WINDING # 35WGG198

Typical performance - not guaranteed values.

1 HP 3 PH 60 HZ 1770 RPM 575 V 3522M

TORQUES (LB-FT): PO=16.37 PU=7.31 LR=10.16 LRA=12.72

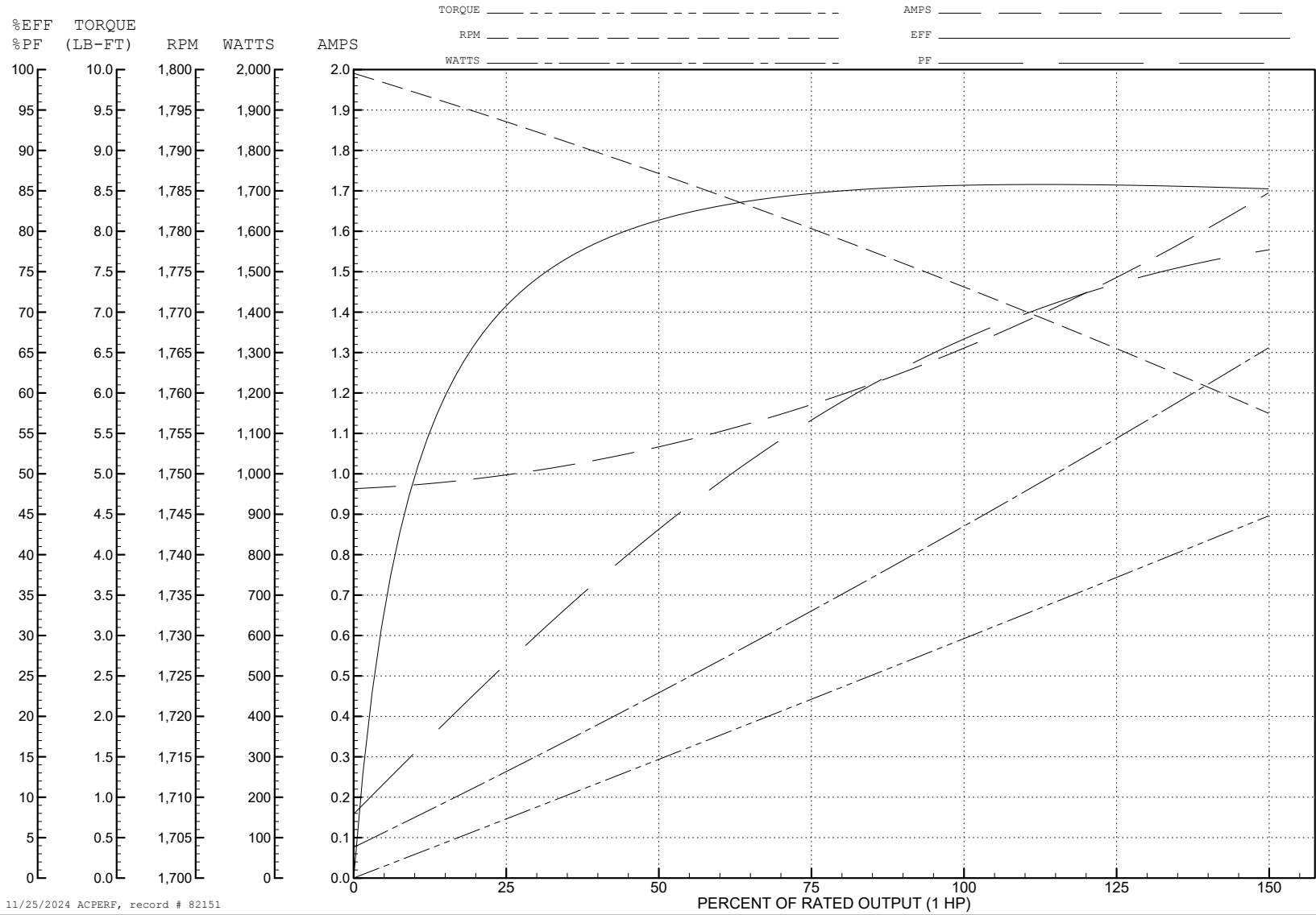

11/25/2024 ACPERF, record # 82151

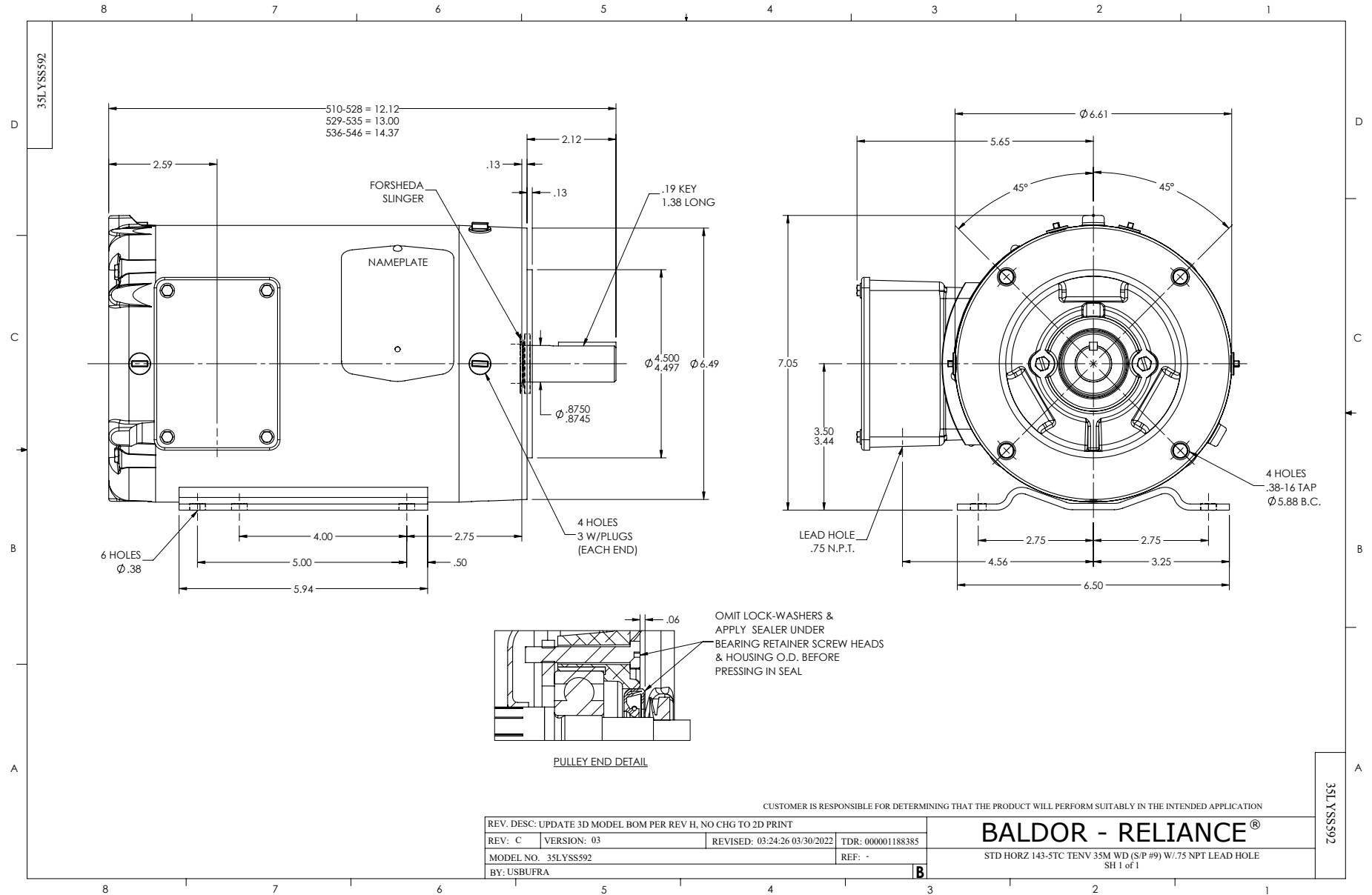

CD0006



NOTES:

1. THREE LEAD MOTOR MAY BE EITHER WYE CONNECTED OR DELTA CONNECTED.
2. INTERCHANGE ANY TWO LINE LEADS TO REVERSE ROTATION.
3. OPTIONAL THERMOSTATS ARE PROVIDED WHEN SPECIFIED.
4. ACTUAL NUMBER OF INTERNAL PARALLEL CIRCUITS MAY VARY.
5. LEAD COLORS ARE OPTIONAL. LEADS MUST BE NUMBERED AS SHOWN.

CD0006

REV. DESC: ADD CLASS CONN00000007		
REV. LTR: E	VERSION: 01	TDR: 000001099922
FILE: \AAA\00005\141	REVISED: 10:24:49 02/19/2019	BY: ENBRIRO
MTL: -	© □	

BALDOR - RELIANCE®

3PH, SV, 3 LEADS, WYE OR DELTA CONNECTED

SH 1 of 1