

BALDOR • RELIANCE

Customer information packet

CEWDM4338T

30HP, 890RPM, 3PH, 60HZ, 364TC, TEFC, F1

Class - None

Division - Not Applicable

Specifications

Enclosure	TEFC
Frame	364TC
Frame Material	Iron
Frequency	60.00 Hz
Haz Area Class and Group	None
Haz Area Division	Not Applicable
Motor Letter Type	Three Phase
Output @ Frequency	30.000 HP @ 60 HZ
Phase	3
Synchronous Speed @ Frequency	900 RPM @ 60 HZ
Voltage @ Frequency	230.0 V @ 60 HZ 460.0 V @ 60 HZ
Agency Approvals	CSA EEV CCSA US
Ambient Temperature	40 °C
Auxillary Box	No Auxillary Box
Base Indicator	Rigid
Bearing Grease Type	Polyrex EM (-20F +300F)
Current @ Voltage	80.000 A @ 230.0 V 40.000 A @ 460.0 V
Design Code	B
Drip Cover	No Drip Cover
Duty Rating	CONT
Efficiency @ 100% Load	91.7 %
Enclosure Modification	Severe Duty Features
Feedback Device	NO FEEDBACK
Heater Indicator	No Heater
High Voltage Full Load Amps	40.0 a
Insulation Class	F
Inverter Code	Inverter Ready
IP Rating	IP55
KVA Code	G

Part detail

Revision	A
Type	AC
Mech. spec.	
Base	
Status	PRD/A
Elec. spec.	A36WG0229
Layout	617428-348
Eff. date	09-10-2021
CD Diagram	416820-002
Poles	08
Leads	3#6,6#8
Proprietary	False
Created date	08-22-2019

Lifting Lugs	Standard Lifting Lugs
Motor Lead Quantity/Wire Size	3 @ 6 AWG
Motor Standards	NEMA
Motor Type	A36050M
Mounting Arrangement	F1
Number of Poles	8
Overall Length	33.48 IN
Power Factor	76
Product Family	Washdown Features
Pulley End Bearing Type	Ball
Pulley Face Code	C-Face
Service Factor	1.15
Shaft Diameter	2.374 IN
Shaft Ground Indicator	No Shaft Grounding
Shaft Rotation	Reversible
Shaft Slinger Indicator	Shaft Slinger
Speed	890 rpm
Speed Code	Single Speed
Starting Method	Direct on line
Thermal Device - Bearing	None
Thermal Device - Winding	None

Nameplate

NP2496L	
MOBIL POLYREX EM	

NP2428L

SPEC NO.	A36-7775-0229	CAT.NO.	CEWDM4338T	FRAME	364TC
HP	30	VOLTS	230/460	PHASE	3
				DESIGN	B
				TYPE	P
RPM	890	AMPS	80/40	HZ	60
				AMB	40
				SF	1.15
DRIVE END BEARING	65BC03JGG30A	DUTY	CONT	INSUL.CLASS	F
OPP D.E. BEARING	65BC03JGG30A	ENCL	TEFC	CODE	G
SER.NO.		POWER FACTOR	76	NEMA-NOM-EFFICIENCY	91.7
				MAX CORR KVAR	10
				GUARANTEED EFFICIENCY	90.2
	IP55			NEMA NOM/CSA QUOTED EFF	
	10:1CT AND 10:1VT ON VPWM INVE			RTER, 1.00SF	
				MOTOR WEIGHT	

Parts list

Part number	Description	Quantity
SA373333	SA A36-7775-0229	1.000 ea
RA363125	RA A36-7775-0229	1.000 ea
421948032	LABEL, MYLAR	1.000 ea
NP2496L	MOTOR LUBE NAMEPLATE	1.000 ea
000613006PU	N/P (RELEASE QTY 10,000) UL CSA LABEL	1.000 ea
000692000CY	N/P	1.000 ea
000692000VD	LABEL WARNING	1.000 ea
NP2428L	WASHDOWN DUTY MOTOR, SS, CC, CSA-C	1.000 ea
085922073B	BRKT 360 085922072WCC KB	1.000 ea
415072001B	CLAMP	1.000 ea
078559075	FAN CVR E360 TEFC W/ NO LUBE ENTRY	1.000 ea
034180012DA	KEY 1X4X1/4X1-1/2 L	1.000 ea
412118006A	DRAIN	1.000 ea
078557001F	FAN KB 110/50 (60) 360	1.000 ea
004824015A	GREASE POLYREX EM	0.540 lb
032018012DN	HHCS 1/2-131-1/2 304S.S.	4.000 ea
032018008AN	HHCS 1/4-20X1 304 S.S.	4.000 ea
032018024CN	HHCS 3/8-16X3 304 S.S.	3.000 ea
415045002E	SLGR	1.000 ea
410700004F	WSHR	1.000 ea
423709011C	WASHER	3.000 ea
034690001AB	1/8" NPT SQHDPLG	1.000 ea
034690002AB	PPLG 1/4" PLTD.	1.000 ea
034690001AB	1/8" NPT SQHDPLG	1.000 ea
034690002AB	PPLG 1/4" PLTD.	1.000 ea
085922070HF	E360 C FACE BRACKET 6313 BRG TEFC- 4.640	1.000 ea
032018012DN	HHCS 1/2-131-1/2 304S.S.	4.000 ea
032018024CN	HHCS 3/8-16X3 304 S.S.	3.000 ea
415045002E	SLGR	1.000 ea
415028001AL	SEAL	1.000 ea
412118006A	DRAIN	1.000 ea

423709011C	WASHER	3.000 ea
076708141	CAST IRON 3" LEAD OUTLET	1.000 ea
065776000C	GASKET,MAIN CBOX, 320-400	1.000 ea
076709000A	C/B Cover - 360	1.000 ea
067053000B	GASK 320-400	1.000 ea
032018006AN	HHCS1/4-20X3/4304S.S.-360	4.000 ea
032018010CN	HHCS 3/8-16X1-1/4 304S.	4.000 ea
415000115H	T/LUG #2AWG-4/0AWG	1.000 ea
406099000A	PLUG - FAN COVER 320-440	1.000 ea
032018005DL	1/2-13 X 5/8 SILICON BRONZE HHCS	1.000 ea
034000014AF	WSHR 3/8 304 S.S.	4.000 ea
004824003AJF	WILKO781.01 WHITE2 COATS - MG1025W01	0.250 ga
033775004EA	DRSCR #6-1/4 304 S.S.	2.000 ea
033775004EA	DRSCR #6-1/4 304 S.S.	4.000 ea
034180034HA	KEY 5/8X5/8X4-1/4 L	1.000 ea
14PA1000	PACKAGING 314 GROUP COMBINED PRINT	1.000 ea
HW1000A32	5/16 FL WASHER WIDE,ID=.344,OD=1.125	3.000 ea
032509020C	CARRIAGE BOLT - 360	3.000 ea

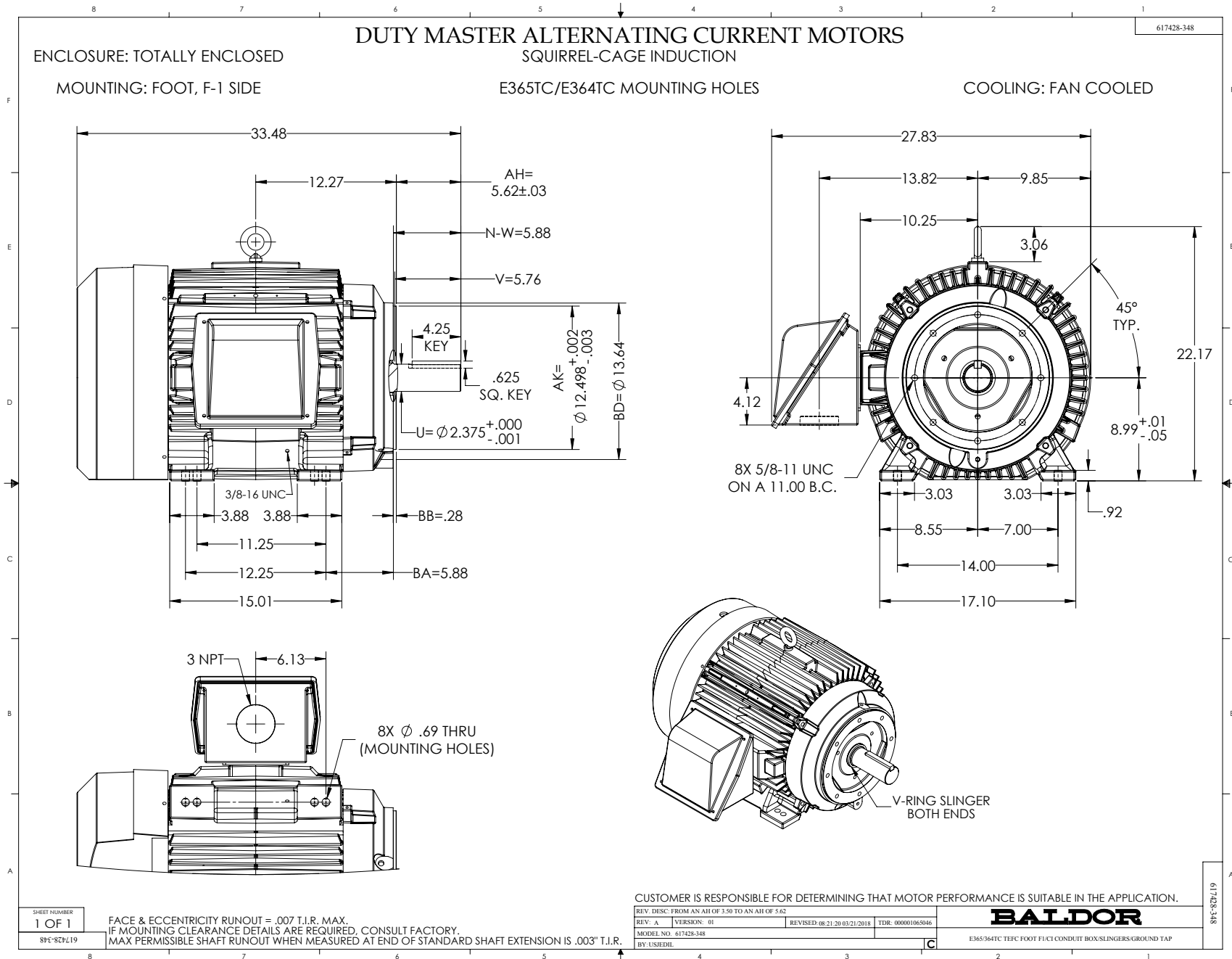

416820-002

A-C MOTOR
 CONNECTION DIAGRAM
 STANDARD 9 LEAD DELTA-CONNECTED

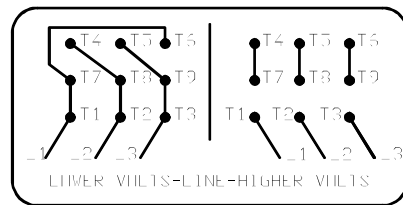
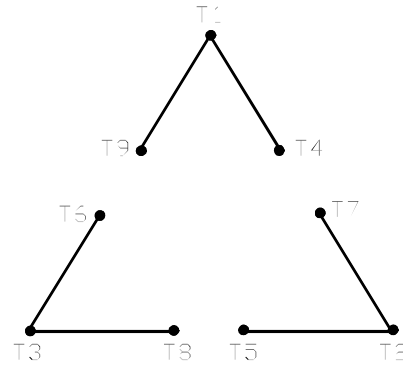

(N.P. 1575-B)

416820-002

REV. DESC: FONT CHANGE FOR PDF SEARCHABLE		
REV. LTR: A	VERSION: 01	TDR: 000001009382
FILE: \MGA\00000\661	REVISED: 02:46:19 02/13/2020	BY: MGHMTT
MTL: -	© □	

BALDOR - RELIANCE®

CONN DIAG - STANDARD 9 LEAD, DELTA-CONNECTED

SH 1 of 1