



Customer information packet

ECP844306TR-4

300HP, 1190RPM, 3PH, 60HZ, L449T, TEFC, F1

Class - None

Division - Division II

Specifications

Enclosure	TEFC
Frame	L449T
Frame Material	Iron
Frequency	60.00 Hz
Haz Area Class and Group	None
Haz Area Division	Division II
Motor Letter Type	Three Phase
Output @ Frequency	300.000 HP @ 60 HZ
Phase	3
Synchronous Speed @ Frequency	1200 RPM @ 60 HZ
Voltage @ Frequency	460.0 V @ 60 HZ
Agency Approvals	CCSAUSEEV
Ambient Temperature	40 °C
Auxillary Box	No Auxillary Box
Base Indicator	Rigid
Bearing Grease Type	Mobil SHC 220 (Athens Only)
Constant Torque Speed Range	30-60
Current @ Voltage	340.000 A @ 460.0 V
Design Code	B
Drip Cover	No Drip Cover
Duty Rating	CONT
Efficiency @ 100% Load	95.8 %
Enclosure Modification	841
Feedback Device	NO FEEDBACK
Frame Prefix	L
Haz Area Temp Code	T3
Heater Indicator	No Heater
High Voltage Full Load Amps	340.0 a
Insulation Class	F
Inverter Code	Inverter Ready
KVA Code	G
Motor Lead Quantity/Wire Size	6 @ 2/0 AWG

Part detail

Revision	F
Type	AC
Mech. spec.	
Base	
Status	PRD/A
Elec. spec.	A44WG4970
Layout	617434-820
Eff. date	03-18-2024
CD Diagram	416820-036
Poles	06
Leads	3#2/0 (02 per group)
Proprietary	False
Created date	12-19-2019

Motor Standards	NEMA
Motor Type	A44208M
Mounting Arrangement	F1
Number of Poles	6
Overall Length	60.47 IN
Power Factor	86
Product Family	General Industrial
Pulley End Bearing Type	Roller
Pulley Face Code	Standard
Service Factor	1.00
Shaft Diameter	3.375 IN
Shaft Ground Indicator	No Shaft Grounding
Shaft Rotation	Reversible
Shaft Slinger Indicator	No Slinger
Speed	1190 rpm
Speed Code	Single Speed
Starting Method	Direct on line
Thermal Device - Bearing	None
Thermal Device - Winding	None

Nameplate

NP2496L	
MOBIL SHC -220 GREASE	

NP4566

CAT NO	ECP844306TR-4	SPEC NO.	A44-8814-4970						
HP	300	AMPS	340	VOLTS	460	DESIGN	B		
FRAME SIZE	L449T	RPM	1190	HZ	60	AMB	40	SF	1.00
D.E. BRG.DATA	NU222	O.D.E. BRG.DATA	6318	PH	3	DUTY	CONT	INSUL.CLASS	F
D.E. BRG.	110RU02M30X	TYPE	ENCL	TEFC	CODE	G			
O.D.E. BRG.	90BC03J30X	POWER FACTOR	86	NEMA-NOM-EFFICIENCY	95.8				
3/4 LOAD EFF.	96.1	IP	56	MAX CORR KVAR	61	GUARANTEED EFFICIENCY	95		
TEMP CODE	T3	TEMP =	200						
CHP HZ	60-90	CT HZ	30-60	VT HZ	0-60				
INVERTER-TEMP-CODE	T3								
SER.NO.		MOTOR WEIGHT							

Parts list

Part number	Description	Quantity
SA377374	SA A44-8814-4970	1.000 ea
RA367291	RA A44-8814-4970	1.000 ea
421948051	LABEL, MYLAR	1.000 ea
NP2496L	MOTOR LUBE NAMEPLATE	1.000 ea
000613006PU	N/P (RELEASE QTY 10,000) UL CSA LABEL	1.000 ea
000692000RT	N/P	1.000 ea
000692000FF	N/P	1.000 ea
000692000VD	LABEL WARNING	1.000 ea
LB1449	DIV-2/NEC WARNING LABEL	1.000 ea
NP4566	SS INV IEEEE841-2021,CLI DIV2,CURUS-E,CSA	1.000 ea
412118006A	DRAIN	2.000 ea
034690005AB	PPLG 3/4 PLATED	1.000 ea
089490099D	G28 BRKT 089490098WCA	1.000 ea
083199082A	G28 FAN COVER MACHINING SHORT VERSION	1.000 ea
034180014DA	KEY 1/4X1/4X1-3/4 L	1.000 ea
702618011RN	FAN 440 702618004T - 2.00 BORE 17.5 DIA	1.000 ea
004824015AP	GREASE MOBILITH SHC 220	1.160 lb
032018020FK	HHCS 3/4-10X2-1/2 PLTD.	4.000 ea
032018008CK	HHCS 3/8-16X1L PLATED	4.000 ea
032018030DK	HHCS 1/2-13X3-3/4 PLTD.	3.000 ea
415096002A	CPLG 1/8 HEX TYPE	1.000 ea
418151014G	RETAIN RING	1.000 ea
423709011D	WASHER	3.000 ea
035000001G	GREASE RELIEF FITTING, ALEMITE 317400	1.000 ea
034017014AB	LCKW 3/8 STD. PLATED	4.000 ea
034530064AB	P/NIP 1/8 X 8" L Pipe Nipple	1.000 ea
415028079H	INPRO SEAL,.625 WIDE,318 BRG	1.000 ea
034631002AB	BUSH 1/4 TO 1/8 PLTD.	1.000 ea
034530064BB	P/NIP 1/4X8 PLATED	1.000 ea
702623022AB	G28 DE AIR SCOOP-HIGH IMPACT PLASTIC-	1.000 ea
418151014H	RETAIN RING	1.000 ea

034530056BB	P/NIP 1/4X7 SCHED 40	1.000 ea
702623013A	THERMAL BARRIER -- G28 -- BRACKET MTD	1.000 ea
032018004BK	HHCS 5/16-18X1/2 PLATED	3.000 ea
034017013AB	LCKW 5/16 STD. PLATED	3.000 ea
034631002AB	BUSH 1/4 TO 1/8 PLTD.	1.000 ea
089490101C	G28 BRKT 089490100WCA	1.000 ea
032018020FK	HHCS 3/4-10X2-1/2 PLTD.	4.000 ea
032018030DK	HHCS 1/2-13X3-3/4 PLTD.	3.000 ea
423709011D	WASHER	3.000 ea
034530056AB	1/8 X 7 PP NIPPLE	1.000 ea
415096002A	CPLG 1/8 HEX TYPE	1.000 ea
415028079J	INPRO SEAL, .625 WIDE, 222 BRG	1.000 ea
035000001G	GREASE RELIEF FITTING, ALEMITE 317400	1.000 ea
032018006BK	HHCS 5/16-18X3/4 PLATED	3.000 ea
415915007G	GASK, LAC	1.000 ft
076870000BA	CONDUIT BOX - 440 - 1/2-13 GROUND	1.000 ea
415039018A	TERBD, 440	1.000 ea
076871000A	+CBOX CVR BLKT - 449	1.000 ea
067053014A	GASK 440	1.000 ea
418150003A	GREASE FITTING CAP	1.000 ea
032018008BK	HHCS 5/16-18X1L PLATED	4.000 ea
032018008DK	HHCS 1/2-13X1 PLATED	4.000 ea
032620016LA	SOCKET SET SCREW-449	3.000 ea
035000001A	ALFTG 1/8" 1610-BL	1.000 ea
415000115H	T/LUG #2AWG-4/0AWG	1.000 ea
406099000A	PLUG - FAN COVER 320-440	1.000 ea
032018005DL	1/2-13 X 5/8 SILICON BRONZE HHCS	1.000 ea
035000001A	ALFTG 1/8" 1610-BL	1.000 ea
418150003A	GREASE FITTING CAP	1.000 ea
MG1025N19	WILKO 778.50 BLUE GREEN - 55 GAL DRUMS	0.500 ga
033775004EA	DRSCR #6-1/4 304 S.S.	8.000 ea
034180054KA	7/8 SQ X 6.75 KEY	1.000 ea
604797032	447/449 WIDE SHIPPING SKID 70" X 55"	1.000 ea
032510026D	CARRIAGE BOLT - 440	2.000 ea

034001016AB	WSHR .562ID 1.375OD .109	2.000 ea
034001014AB	FLAT WASHER 3/8"PLATED	2.000 ea
033300014AC	HEX NUT, SHIPPING - 400	2.000 ea
604799003C	PLASTIC BAG 42X32X46	1.000 ea
604797001R	440 FR. ROLLER BEARING MOTOR SHAFT	1.000 ea
032018028CK	HHCS 3/8-16X3-1/2 PLTD.	1.000 ea
034001016AB	WSHR .562ID 1.375OD .109	1.000 ea
034001014AB	FLAT WASHER 3/8"PLATED	1.000 ea

617434-820

ENCLOSURE: TOTALLY ENCLOSED

DUTY MASTER ALTERNATING CURRENT MOTORS

SQUIRREL-CAGE INDUCTION

COOLING: FAN COOLED

MOUNTING: FOOT, F-1

GL449T/G449T FRAME MOUNTING
CENTER OF GRAVITY

841-XL ENHANCEMENT

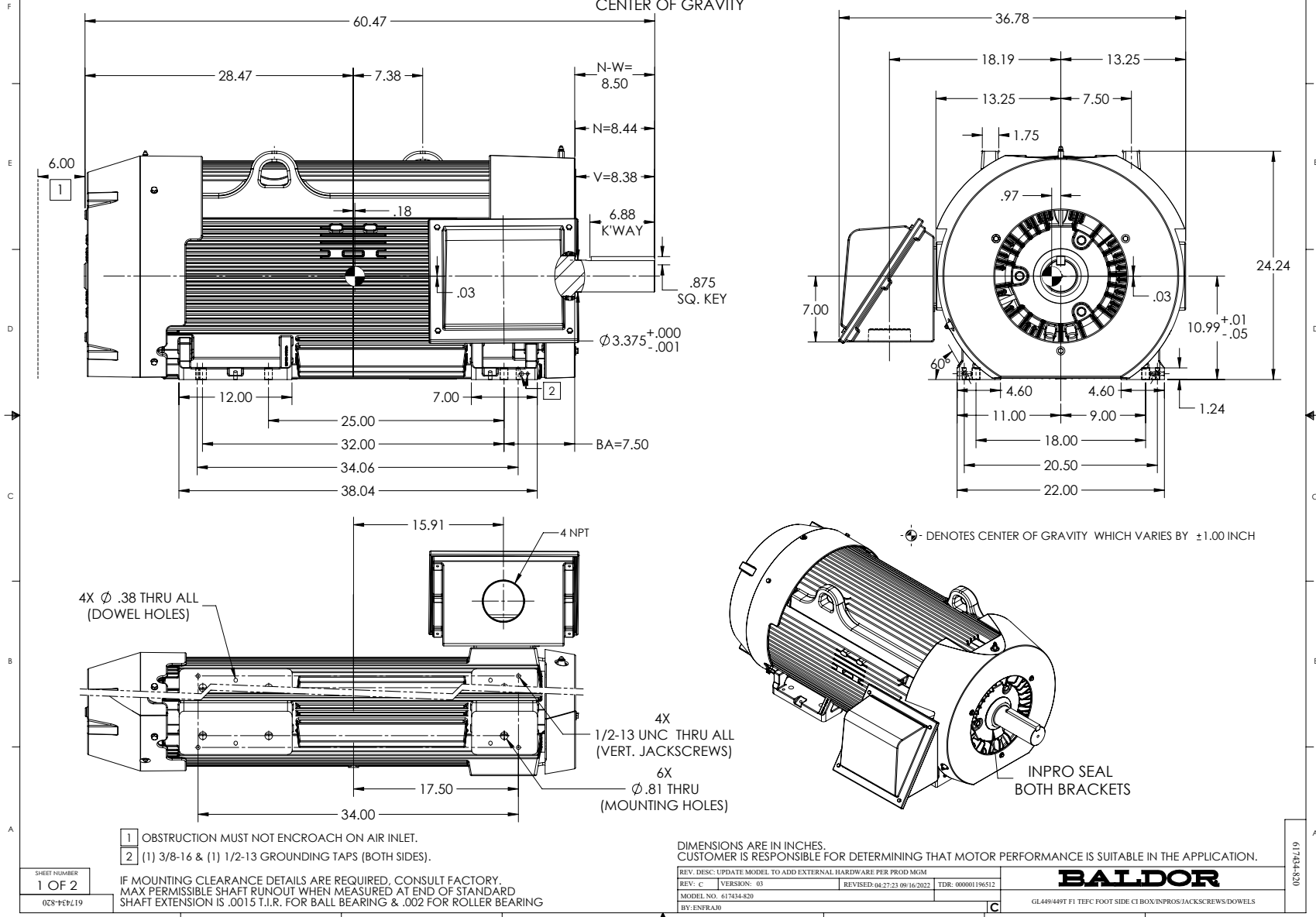

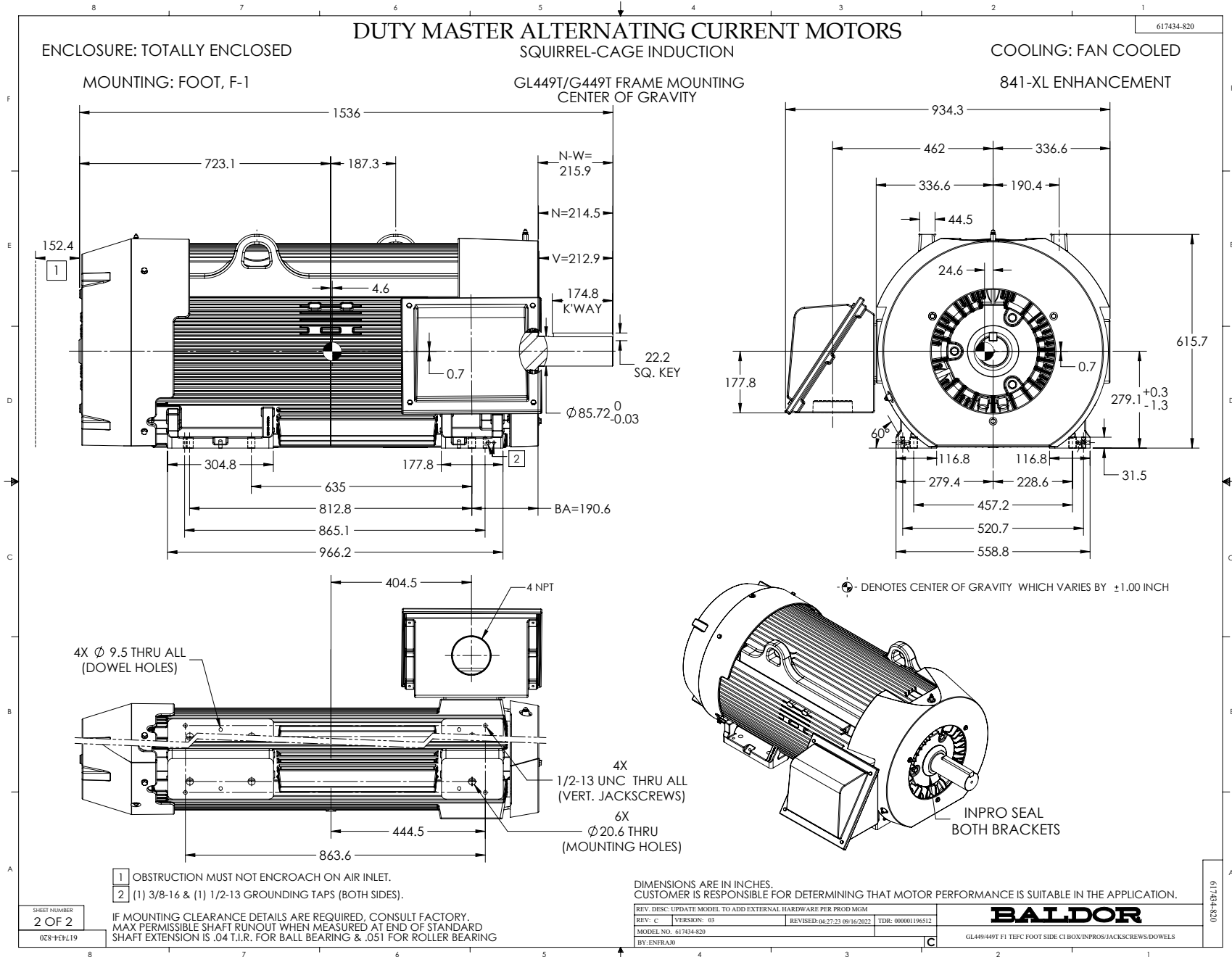

416820-036

A-C MOTOR
CONNECTION DIAGRAM
STANDARD 3 LEAD CONNECTED

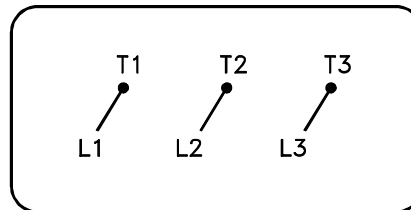

(N.P. 1575-BA)

416820-036

REV. DESC: LOADED TO BUS, C/R 335225		
REV. LTR: -	VERSION: 00	TDR: 000000538207
FILE: \MGA\00000\682	REVISED: 11: 54: 06 04/30/2010	
MTL: -	BY: RAGRA	

BALDOR

CONN DIAG - STANDARD 3 LEAD
SH 1 of 1