

**BALDOR • RELIANCE**

---

# Customer information packet

## ECS101M0H5EF4

5HP, 1800RPM, 3PH, 60HZ, 184T, TEFC, N

Class - None

Division - Not Applicable

Copyright © All product information within this document is subject to ABB Motors and Mechanical Inc. copyright © protection, unless otherwise noted.

11/26/2024 10:48:08 PM

## Specifications

Enclosure	TEFC
Frame	184T
Frame Material	Steel
Frequency	60.00 Hz
Haz Area Class and Group	None
Haz Area Division	Not Applicable
Motor Letter Type	Three Phase
Phase	3
Agency Approvals	UL WEEE
Auxillary Box	No Auxillary Box
Auxillary Box Lead Termination	None
Base Indicator	Rigid
Bearing Grease Type	Polyrex EM (-20F +300F)
Blower	None
Constant Torque Speed Range	6
Design Code	B
Drip Cover	No Drip Cover
Duty Rating	CONT
Electrically Isolated Bearing	Not Electrically Isolated
Feedback Device	NO FEEDBACK
Front Shaft Indicator	None
Heater Indicator	No Heater
Insulation Class	F
Inverter Code	Inverter Duty
IP Rating	NONE
Lifting Lugs	Standard Lifting Lugs
Locked Bearing Indicator	Locked Bearing
Motor Lead Quantity/Wire Size	9 @ 12 AWG
Motor Lead Termination	Flying Leads
Motor Standards	NEMA
Motor Type	3632B

## Part detail

Revision	S
Type	AC
Mech. spec.	36T257
Base	
Status	PRD/A
Elec. spec.	36WGL051
Layout	36LYT257
Eff. date	05-01-2024
CD Diagram	CD0005
Poles	04
Leads	9#12
Proprietary	False
Created date	12-12-2018

<b>Mounting Arrangement</b>	F1
<b>Number of Poles</b>	4
<b>Overall Length</b>	16.54 IN
<b>Product Family</b>	General Purpose
<b>Pulley End Bearing Type</b>	Ball
<b>Pulley Face Code</b>	Standard
<b>Pulley Shaft Indicator</b>	Standard
<b>Rodent Screen</b>	None
<b>RoHS Status</b>	ROHS COMPLIANT
<b>Shaft Diameter</b>	1.125 IN
<b>Shaft Ground Indicator</b>	Shaft Grounding
<b>Shaft Rotation</b>	Reversible
<b>Shaft Slinger Indicator</b>	No Slinger
<b>Speed Code</b>	Single Speed
<b>Starting Method</b>	INVERTER SPECIAL
<b>Thermal Device - Bearing</b>	None
<b>Thermal Device - Winding</b>	None
<b>Vibration Sensor Indicator</b>	No Vibration Sensor
<b>Winding Thermal 1</b>	None
<b>Winding Thermal 2</b>	None

**Nameplate**

<b>NP3968A01A01</b>									
<b>CAT.NO.</b>	ECS101M0H5EF4								
<b>SPEC.</b>	36T257L051G1								
<b>FRAME</b>	184T		<b>ENCL.</b>	TEFC	<b>IP</b>	54			
<b>HP</b>	5	40	<b>C AMB</b>		<b>CONT</b>				
<b>NOM. EFF.</b>	93.7%	<b>PF</b>	97.3%	<b>SF</b>	1.50				
<b>VOLTS</b>	230/460		<b>FLA</b>	10.5/5.3					
<b>RPM</b>	1800		<b>RPM-MAX</b>	4000					
<b>HZ</b>	60	<b>PH.</b>	3	<b>CLASS</b>	F				
<b>BEMF (V)</b>	126/252		<b>RS (OHMS)</b>	0.82/3.30					
<b>LD (MH)</b>	13.5/54.0		<b>LQ (MH)</b>	47.8/191.0					
<b>VPWM</b>	<b>CHP</b>	60	<b>TO</b>	133					
<b>CT</b>	6	<b>TO</b>	60	<b>VT</b>	1	<b>TO</b>	60		
<b>MATCHED INV</b>	ACS380-04XX-[N/A]/07A2-4								
<b>DE</b>	6206		<b>ODE</b>	6205					
<b>SERIAL #</b>									

## Parts list

Part number	Description	Quantity
SA364017	SA 36T257L051G1	1.000 ea
RA353322	RA 36T257L051G1	1.000 ea
HW3200A01	3/8-16X3/4 EYEBOLT WELDED F/S	1.000 ea
36CB3004	36 CB CASTING W/1.09 DIA LEAD HOLE @ 6:0	1.000 ea
36GS1000SP	GASKET-CONDUIT BOX, .06 THICK #SV-330 LE	1.000 ea
51XB1016A07	10-16 X 7/16 HXWSSLD SERTYB	2.000 ea
11XW1032G06	10-32 X .38, TAPTITE II, HEX WSHR SLTD U	1.000 ea
36EP3104A02	FREP MACH W/O GRSR, RAISED FH PADS	1.000 ea
HA4067A01	PUSH IN DRAIN FITTING (BLACK)	1.000 ea
XY2520A12	1/4-20 HEX NUT, DIRECTIONAL SERRATIONS	4.000 ea
HW5100A05	WVY WSHR F/205 & 304 BRGS	1.000 ea
36EP3100A42	PU EP, LOCKED 206 BRG, NO GRS	1.000 ea
10XN2520A20	1/4-20X 1 1/4 HEX HD X	2.000 ea
HA4067A01	PUSH IN DRAIN FITTING (BLACK)	1.000 ea
36FH4009A101	IEC FH NO GREASER, W/PRIMER	1.000 ea
51XW1032A06	10-32 X .38, TAPTITE II, HEX WSHR SLTD S	3.000 ea
36CB4516	750LIPPED CB LID - GALVANNEAL	1.000 ea
37GS1001	GASKET, CONDUIT BOX LID, .06 THICK LEXID	1.000 ea
51XW0832A07	8-32 X .44, TAPTITE II, HEX WSHR SLTD SE	4.000 ea
HW4600B36SP	V-RING SLINGER 1.188 X 1.690 X .24 VITON	1.000 ea
HW2501E16	KEY, 1/4 SQ X 1.750	1.000 ea
HA7000A02	KEY RETAINER RING, 1 1/8 DIA, 1 3/8 DIA	1.000 ea
MJ1000A02	GREASE, POLYREX EM EXXON	0.050 lb
36FN3000A01SP	EXFN, PLASTIC, 7.00 OD, .912 ID	1.000 ea
51XB1214A16	12-14X1.00 HXWSSLD SERTYB	1.000 ea
HA3101A25	THRUBOLT 1/4-20 X 11.000 OHIO ROD	4.000 ea
MG1050G01	CELEROL MEDIUM CHARCOAL METALLIC GRAY	0.022 ga
LC0005	CONN.DIA.,TY M,9-LD,DUAL VOLT,REVERSING	1.000 ea
NP3968A01A01	NP LABEL WEE, SH GND, C-UL-US, QR, ECS	1.000 ea
36PA1001	PKG GRP, PRINT PK1017A06	1.000 ea
MN451	EC Titanium Quick Start 04/20	1.000 ea

FE-0000001	ZRTG FE ASSEMBLY	1.000 ea
PE-0000001	ZRTG PE ASSEMBLY	1.000 ea
LB1624	COMBINED WARNING LABEL, ISO/ANSI PICTOGR	1.000 ea

36LYT257

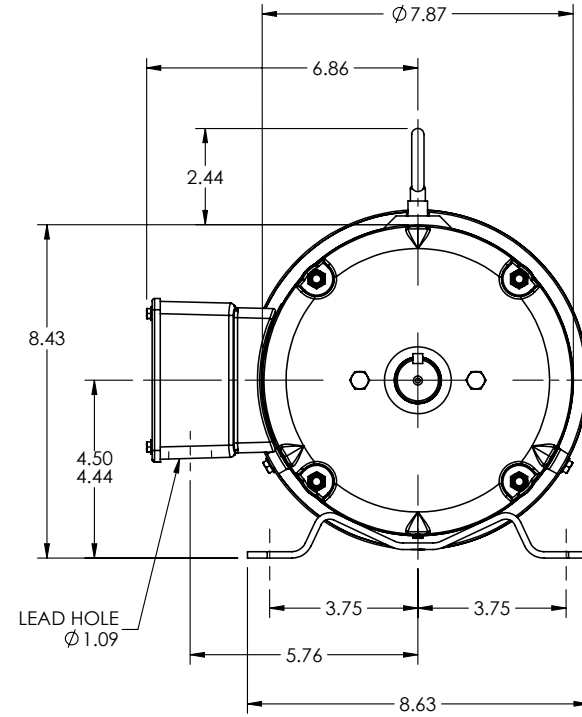
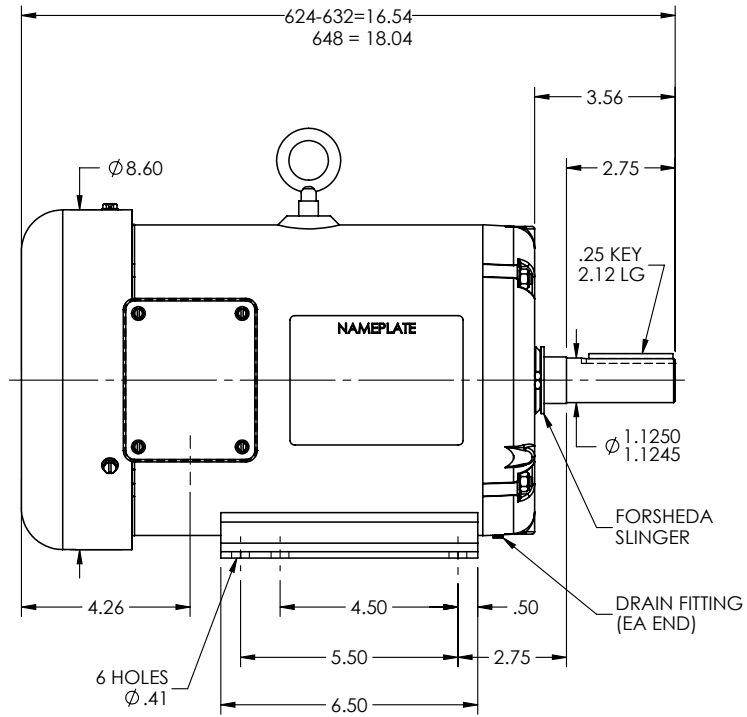

REV. DESC: CHANGE NAMEPLATE TO NP4246A01

REV: K	VERSION: 10	REVISED: 07:22:51 10/06/2022	TDR: 000001196734
--------	-------------	------------------------------	-------------------



MODEL NO. 36LYT257

REF: -

BY: ENALEM0

Material: -

**BALDOR**

HOR 182-4T TEFC B EYEBOLT INT SH GND ECS

36LYT257

CD0005



LOW VOLTAGE  
(2Y)

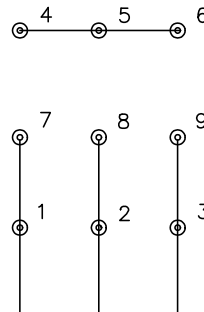

LINE

HIGH VOLTAGE  
(1Y)

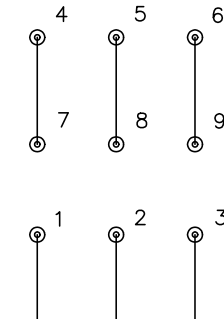

LINE

NOTES:

1. INTERCHANGE ANY TWO LINE LEADS TO REVERSE ROTATION.
2. OPTIONAL THERMOSTATS ARE PROVIDED WHEN SPECIFIED.
3. ACTUAL NUMBER OF INTERNAL PARALLEL CIRCUITS MAY BE A MULTIPLE OF THOSE SHOWN ABOVE.
4. LEAD COLORS ARE OPTIONAL. LEADS MUST ALWAYS BE NUMBERED AS SHOWN.

CD0005

REV. DESC: REVISE TO SHOW OPTIONAL COLORS			
REV. LTR: E	BY: JLP	REVISED: 01/19/99 10:15	TDR: 0171435
S00000		FILE: AAA00005140	MDL: -
		MTL: -	

**BALDOR ELECTRIC Co.**

3PH, DV, 9 LEADS