

BALDOR • RELIANCE

Customer information packet

EM2551T-CI

75HP, 1780RPM, 3PH, 60HZ, 365T, ODP, FOOT,
Class - None
Division - Not Applicable

Specifications

Enclosure	DP
Frame	365T
Frame Material	Iron
Frequency	60.00 Hz
Haz Area Class and Group	None
Haz Area Division	Not Applicable
Motor Letter Type	Three Phase
Output @ Frequency	75.000 HP @ 60 HZ
Phase	3
Synchronous Speed @ Frequency	1800 RPM @ 60 HZ
Voltage @ Frequency	230.0 V @ 60 HZ 460.0 V @ 60 HZ
Agency Approvals	CCSAUSEEV
Ambient Temperature	40 °C
Auxillary Box	No Auxillary Box
Base Indicator	Rigid
Bearing Grease Type	Polyrex EM (-20F +300F)
Current @ Voltage	173.000 A @ 230.0 V 86.500 A @ 460.0 V
Design Code	B
Drip Cover	No Drip Cover
Duty Rating	CONT
Efficiency @ 100% Load	95.0 %
Feedback Device	NO FEEDBACK
Heater Indicator	No Heater
High Voltage Full Load Amps	86.5 a
Insulation Class	F
Inverter Code	Inverter Ready
KVA Code	G
Lifting Lugs	No Lifting Lugs
Motor Lead Quantity/Wire Size	3 @ 4 AWG
Motor Standards	NEMA

Part detail

Revision	N
Type	AC
Mech. spec.	
Base	
Status	PRD/A
Elec. spec.	A36WG0189
Layout	617428-116
Eff. date	02-24-2017
CD Diagram	416820-002
Poles	04
Leads	3#4,6#6
Proprietary	False
Created date	10-19-2010

Motor Type	A36056M
Mounting Arrangement	F1
Number of Poles	4
Overall Length	29.70 IN
Power Factor	86
Pulley End Bearing Type	Ball
Pulley Face Code	P-Base
Service Factor	1.15
Shaft Diameter	2.374 IN
Shaft Ground Indicator	No Shaft Grounding
Shaft Rotation	Reversible
Shaft Slinger Indicator	No Slinger
Speed	1780 rpm
Speed Code	Single Speed
Starting Method	Direct on line
Thermal Device - Bearing	None
Thermal Device - Winding	None

Nameplate

NP2377L

CAT.NO.	EM2551T-CI	SPEC NO.	P36G52						
HP	75	AMPS	173/86.5		VOLTS	230/460		DESIGN	B
FRAME	365T	RPM	1780	HZ	60	AMB	40	SF	1.15
DRIVE END BEARING	65BC03J30X	PHASE	3	DUTY	CONT	INSUL.CLASS	F		
OPP D.E. BEARING	65BC03J30X	TYPE	P	ENCL	DP	CODE	G		
SER.NO.		POWER FACTOR	86		NEMA-NOM-EFFICIENCY	95			
		MAX CORR KVAR	15.0		GUARANTEED EFFICIENCY	94.5			
		NEMA NOM/CSA QUOTED EFF							
		MOTOR WEIGHT	762						

Parts list

Part number	Description	Quantity
SA209141	SA P36G52	1.000 ea
RA196403	RA P36G52	1.000 ea
000613006PU	N/P (RELEASE QTY 10,000) UL CSA LABEL	1.000 ea
000692000VD	LABEL WARNING	1.000 ea
NP2377L	SS SUPER-E, CC, CURUS ENERGY (LASER)	1.000 ea
004824015A	GREASE POLYREX EM	0.544 lb
032018024CK	HHCS 3/8-16X3 PLTD.	3.000 ea
032018028DK	HHCS 1/2-13X3-1/2 PLTD.	4.000 ea
032376004JB	RHMS 10-32X1/2PLTD-360	3.000 ea
034001009AB	WSHR #10 PLATED-360	3.000 ea
034690002AB	PPLG 1/4" PLTD.	1.000 ea
078556001A	BAFFL 360 SUB PAINT	1.000 ea
085920052A	BRKT 360 085920051WCC KB	1.000 ea
410700004F	WSHR	1.000 ea
032018024CK	HHCS 3/8-16X3 PLTD.	3.000 ea
032018028DK	HHCS 1/2-13X3-1/2 PLTD.	4.000 ea
032376004JB	RHMS 10-32X1/2PLTD-360	3.000 ea
034001009AB	WSHR #10 PLATED-360	3.000 ea
034017009AB	LCKW NO.10 PLATED-360	3.000 ea
035000001A	ALFTG 1/8" 1610-BL	1.000 ea
035000001A	ALFTG 1/8" 1610-BL	1.000 ea
034017009AB	LCKW NO.10 PLATED-360	3.000 ea
034690002AB	PPLG 1/4" PLTD.	1.000 ea
078556001A	BAFFL 360 SUB PAINT	1.000 ea
085920052A	BRKT 360 085920051WCC KB	1.000 ea
032018010CK	HHCS 3/8-16X1-1/4 PLTD. 032018010CR	4.000 ea
033512006LB	HHTTS 1/4-20X3/4 PLTD.	4.000 ea
048897010DG	PLUG,ODE BRKT - 360	1.000 ea
065776000C	GASKET,MAIN CBOX, 320-400	1.000 ea
067053000B	GASK 320-400	1.000 ea
076708000BB	CONDUIT BOX-360	1.000 ea

076709000A	C/B Cover - 360	1.000 ea
14PA1000	PACKAGING 314 GROUP COMBINED PRINT	1.000 ea
415000115H	T/LUG #2AWG-4/0AWG	1.000 ea
033775004EA	DRSCR #6-1/4 304 S.S.	2.000 ea
034180034HA	KEY 5/8X5/8X4-1/4 L	1.000 ea
MG1025Y17	WILKOFAST, 789.701, SUPER E PEARL GOLD	0.250 ga
421948032	LABEL, MYLAR	1.000 ea
032018005DL	1/2-13 X 5/8 SILICON BRONZE HHCS	1.000 ea

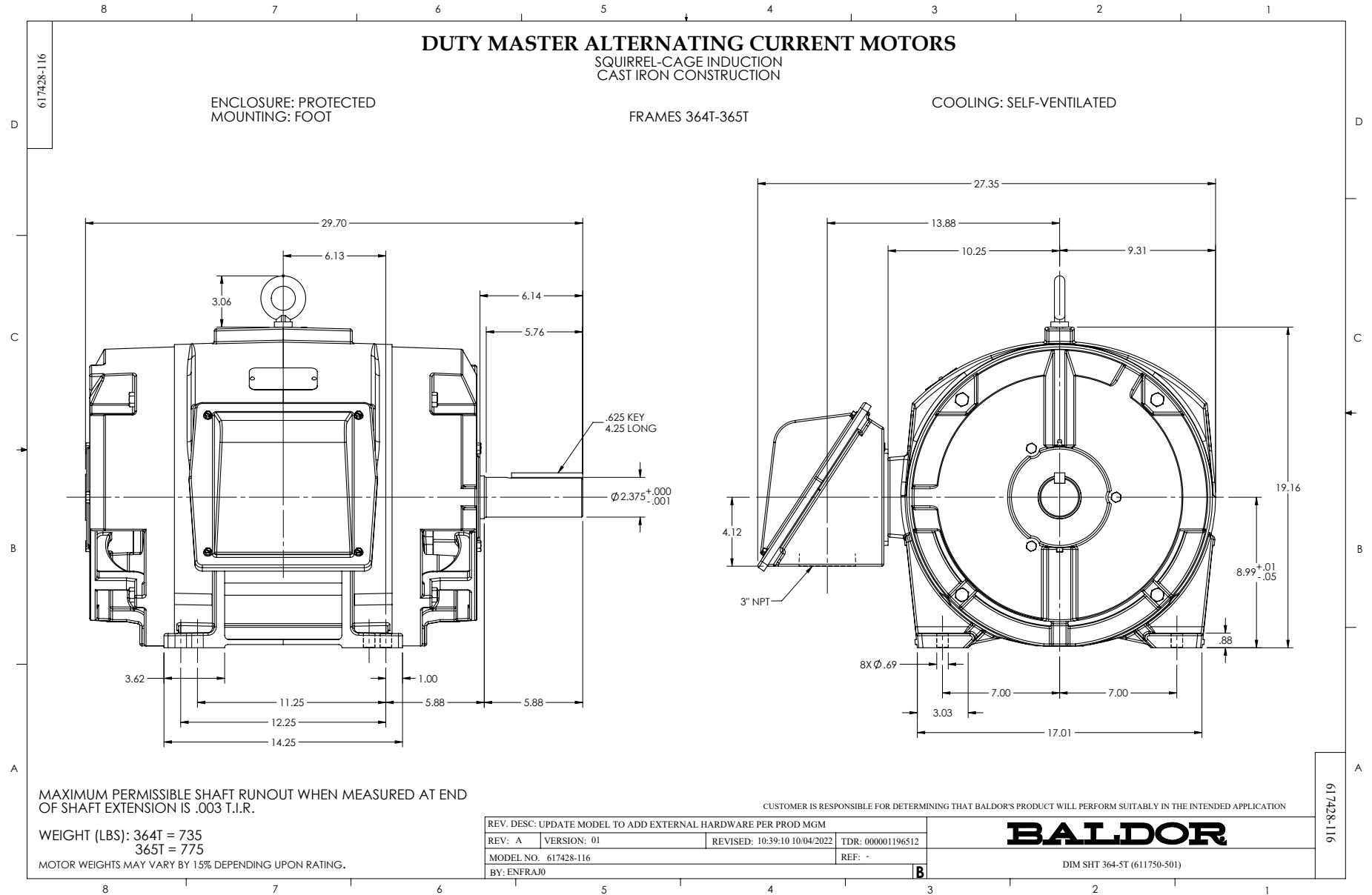

416820-002

A-C MOTOR
 CONNECTION DIAGRAM
 STANDARD 9 LEAD DELTA-CONNECTED

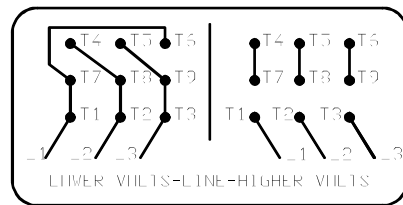
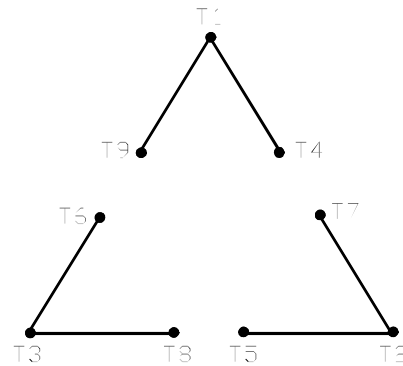

(N.P. 1575-B)

416820-002

REV. DESC: FONT CHANGE FOR PDF SEARCHABLE		
REV. LTR: A	VERSION: 01	TDR: 000001009382
FILE: \MGA\00000\661	REVISED: 02:46:19 02/13/2020	BY: MGHMTT
MTL: -	© □	

BALDOR - RELIANCE®

CONN DIAG - STANDARD 9 LEAD, DELTA-CONNECTED

SH 1 of 1