



Customer information packet

EM3154T-5

1.5HP, 1770RPM, 3PH, 60HZ, 145T, 3524M, OPSB, F

Class - None

Division - Not Applicable

Specifications

Enclosure	OPSB
Frame	145T
Frame Material	Steel
Frequency	60.00 Hz
Haz Area Class and Group	None
Haz Area Division	Not Applicable
Motor Letter Type	Three Phase
Output @ Frequency	1.500 HP @ 60 HZ
Phase	3
Synchronous Speed @ Frequency	1800 RPM @ 60 HZ
Voltage @ Frequency	575.0 V @ 60 HZ
Agency Approvals	CSA EEV NEMA PREMIUM UR
Ambient Temperature	40 °C
Auxillary Box	No Auxillary Box
Auxillary Box Lead Termination	None
Base Indicator	Rigid
Bearing Grease Type	Polyrex EM (-20F +300F)
Blower	None
Current @ Voltage	1.700 A @ 575.0 V
Design Code	B
Drip Cover	No Drip Cover
Duty Rating	CONT
Efficiency @ 100% Load	86.5 %
Electrically Isolated Bearing	Not Electrically Isolated
Feedback Device	NO FEEDBACK
Front Shaft Indicator	None
Heater Indicator	No Heater
High Voltage Full Load Amps	1.7 a
Insulation Class	F
Inverter Code	Inverter Ready

Part detail

Revision	D
Type	AC
Mech. spec.	35BB101
Base	
Status	PRD/A
Elec. spec.	35WGG122
Layout	35LYBB101
Eff. date	06-11-2024
CD Diagram	CD0006
Poles	04
Leads	3#18
Proprietary	False
Created date	03-11-2022

KVA Code	L
Lifting Lugs	No Lifting Lugs
Locked Bearing Indicator	No Locked Bearing
Motor Lead Quantity/Wire Size	3 @ 18 AWG
Motor Lead Termination	Flying Leads
Motor Standards	NEMA
Motor Type	3524M
Mounting Arrangement	F1
Number of Poles	4
Overall Length	11.62 IN
Power Factor	77
Product Family	General Purpose
Pulley End Bearing Type	Ball
Pulley Face Code	Standard
Pulley Shaft Indicator	Standard
Rodent Screen	None
Service Factor	1.15
Shaft Diameter	0.875 IN
Shaft Ground Indicator	No Shaft Grounding
Shaft Rotation	Reversible
Shaft Slinger Indicator	No Slinger
Speed	1770 rpm
Speed Code	Single Speed
Starting Method	Direct on line
Thermal Device - Bearing	None
Thermal Device - Winding	None
Vibration Sensor Indicator	No Vibration Sensor
Winding Thermal 1	None
Winding Thermal 2	None

Nameplate

NP3553L									
CAT.NO.	EM3154T-5								
SPEC	35BB101G122G1								
HP	1.5								
VOLTS	575								
AMPS	1.9								
RPM	1770								
FRAME	145T		HZ	60		PH	3		
SF	1.15	CODE	M	DES	B	CLASS	F		
NEMA NOM. EFF	86.5	PF	74						
RATING	40C AMB-CONT								
CC	010A								
ENCL	OPSB	SER							
DE	6205		ODE	6203					
VPWM INVERTER READY		SFA 1.9							
CT30-60(2:1) VT3-60(20:1)									

Parts list

Part number	Description	Quantity
SA409189	SA 35BB101G122G1	1.000 ea
RA400734	RA 35BB101G122G1	1.000 ea
34FN3002B01	EXTERNAL FAN, PLASTIC, .637/.639 HUB W/	1.000 ea
NS2512A01	INSULATOR, CONDUIT BOX X	1.000 ea
35CB3009	35 CB W/1.09 DIA. LEAD HOLE @ 6:	1.000 ea
51XB1016A06	10-16X3/8 HXWSSLD SERTYB	2.000 ea
11XW1032G06	10-32 X .38, TAPTITE II, HEX WSHR SLTD U	1.000 ea
35EP3209A00	MASTER ODE,203 BRG,GRSR	1.000 ea
HW4500A01	1641B(ALEMITE)400 UNIV, GREASE FITT	1.000 ea
HW5100A03	WAVY WASHER (W1543-017)	1.000 ea
35EP3210A00	MASTER DE,205 BRG,1.000SH,GRSR	1.000 ea
HW4500A01	1641B(ALEMITE)400 UNIV, GREASE FITT	1.000 ea
XY1032A02	10-32 HEX NUT DIRECTIONAL SERRATION	4.000 ea
35CB4521	35 LIPPED CB LID (GALV & PHOSPH)	1.000 ea
51XW0832A07	8-32 X .44, TAPTITE II, HEX WSHR SLTD SE	4.000 ea
HW2501D13	KEY, 3/16 SQ X 1.375	1.000 ea
HA7000A01	KEY RETAINER 7/8" DIA SHAFT	1.000 ea
85XU0407S04	4X1/4 U DRIVE PIN STAINLESS	2.000 ea
MJ1000A02	GREASE, POLYREX EM EXXON	0.050 lb
MG1050Y01	CELEROL BALDOR GOLD *** NLA IN 5 GALLON	0.017 ga
35AD2005A01	BAFFLE PLATE,MOD 35-SLTD BAND MTRS TDR	2.000 ea
HA3100A45	THRUBOLT 10-32 X 8.875	4.000 ea
LB1624	COMBINED WARNING LABEL, ISO/ANSI PICTOGR	1.000 ea
LC0006	CONNECTION LABEL	1.000 ea
NP3553L	ALUM SUPER-E,VPWM INV READY,UL EV,CC,NEM	1.000 ea
35PA1066	PKG GRP, PRINT PK1008A06	1.000 ea
MN416A01	TAG-INSTAL-MAINT no wire (2500bx)4/22	1.000 ea
FE-0000001	ZRTG FE ASSEMBLY	1.000 ea
PE-0000001	ZRTG PE ASSEMBLY	1.000 ea

Accessories

Part number	Description	Multiplier
35-8764	C FACE KIT	A8
35EP1604A01SP	D-FLANGE KIT	A8

AC Induction Motor Performance Data

Record # 87251

Preliminary Data Sheet

Winding: 35WGG122-R005		Type: 3524M		Enclosure: OPEN	
Nameplate Data			575 V, 60 Hz: Single Voltage Motor		
Rated Output (HP)	1.5	Full Load Torque	4.5 LB-FT		
Volts	575	Start Configuration	direct on line		
Full Load Amps	1.7	Breakdown Torque	16.14 LB-FT		
R.P.M.	1770	Pull-up Torque	9.28 LB-FT		
Hz	60 Phase	3	Locked-rotor Torque	9.67 LB-FT	
NEMA Design Code	B	KVA Code	L	Starting Current	13.5 A
Service Factor (S.F.)	1.15	No-load Current	0.985 A		
NEMA Nom. Eff.	86.5	Power Factor	76	Line-line Res. @ 25°C	21.5 Ω
Rating - Duty	40C AMB-CONT		Temp. Rise @ Rated Load	42°C	
S.F. Amps			Temp. Rise @ S.F. Load	50°C	
			Locked-rotor Power Factor	60.8	
			Rotor inertia	0.173 lb-ft ²	

Load Characteristics 575 V, 60 Hz, 1.5 HP

% of Rated Load	25	50	75	100	125	150	S.F.
Power Factor	36	56	70	77	82	84	80
Efficiency	77	84.8	86.4	86.2	85	83.4	85.5
Speed	1791	1783	1774	1765	1755	1743	1759
Line amperes	1.04	1.2	1.42	1.7	2.04	2.4	1.9

ABB Motors and Mechanical Inc.

WINDING # 35WGG122

Typical performance - not guaranteed values.

1.5 HP 3 PH 60 HZ 1770 RPM 575 V 3524M

TORQUES (LB-FT): PO=16.14 PU=9.28 LR=9.67 LRA=13.5

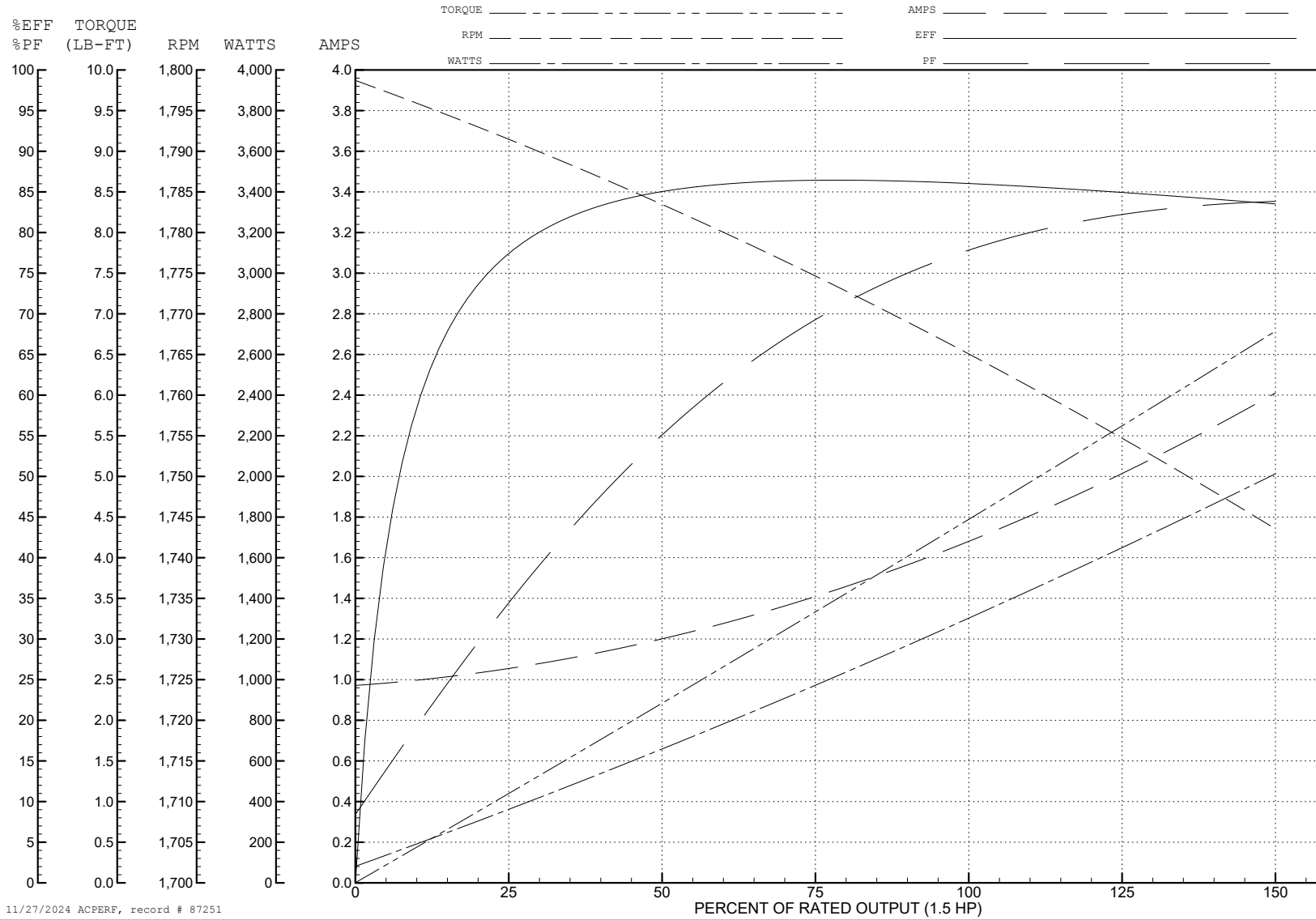

11/27/2024 ACPERF, record # 87251

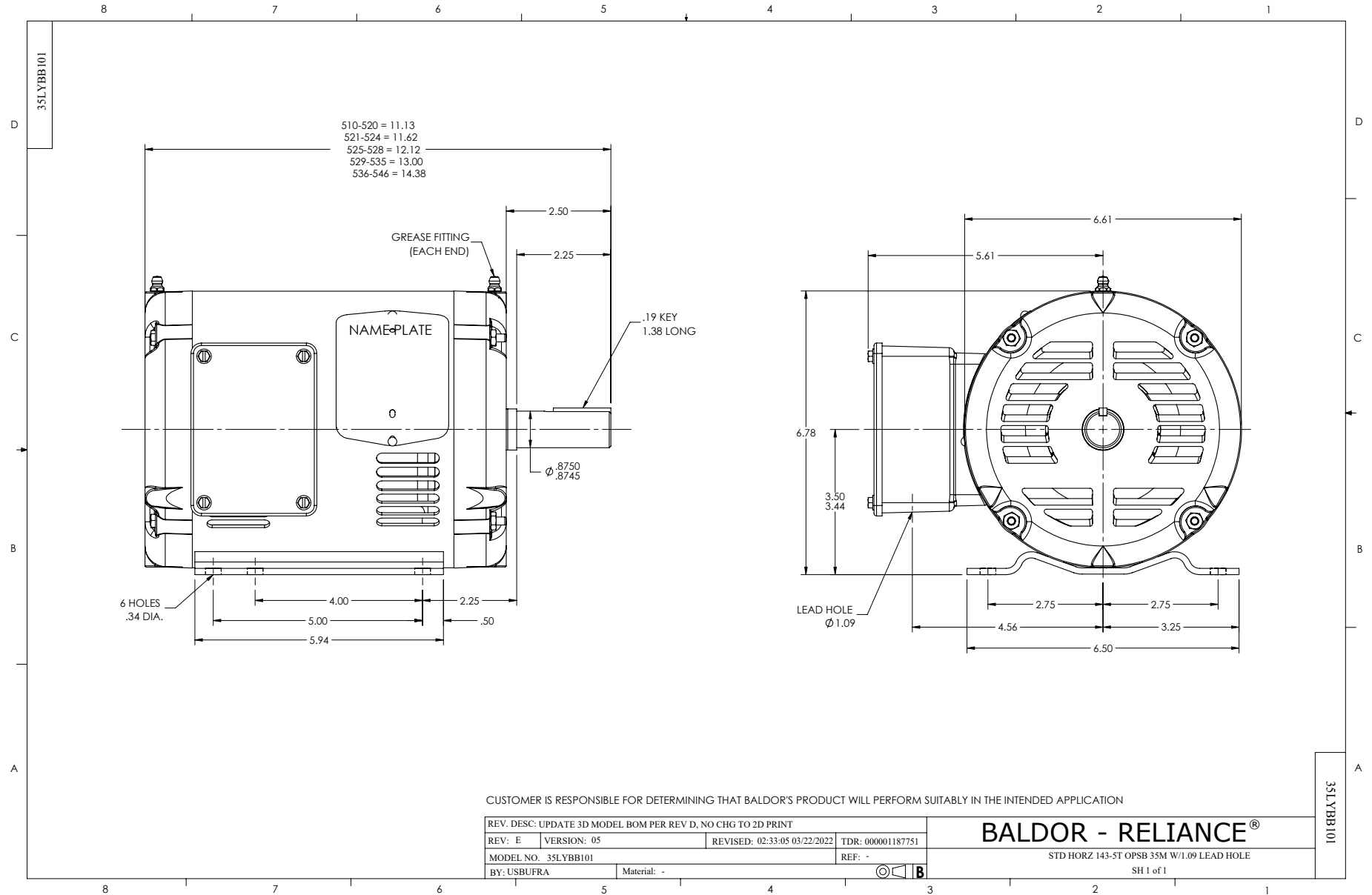

CD0006

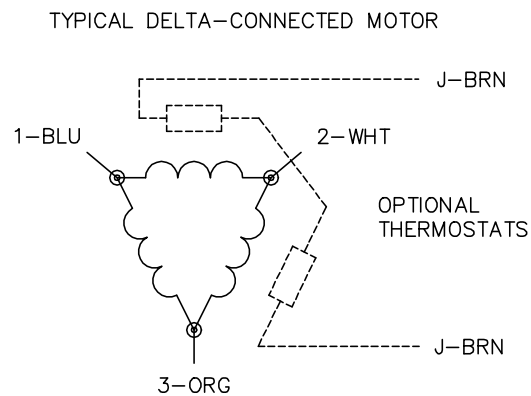
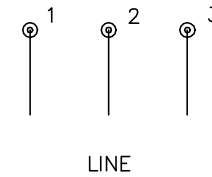
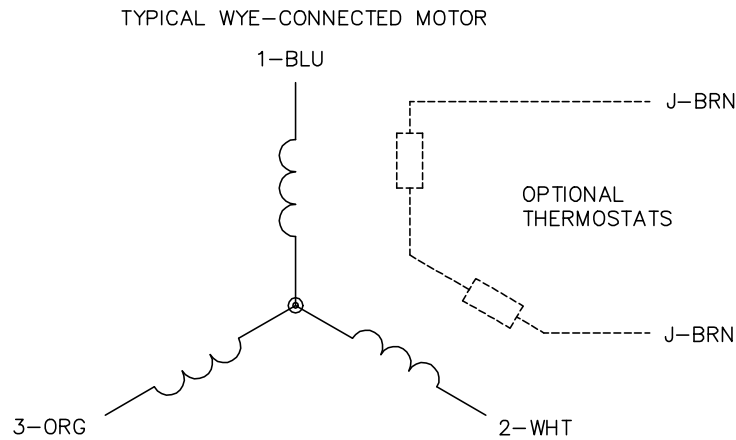

NOTES:

1. THREE LEAD MOTOR MAY BE EITHER WYE CONNECTED OR DELTA CONNECTED.
2. INTERCHANGE ANY TWO LINE LEADS TO REVERSE ROTATION.
3. OPTIONAL THERMOSTATS ARE PROVIDED WHEN SPECIFIED.
4. ACTUAL NUMBER OF INTERNAL PARALLEL CIRCUITS MAY VARY.
5. LEAD COLORS ARE OPTIONAL. LEADS MUST BE NUMBERED AS SHOWN.

CD0006

REV. DESC: ADD CLASS CONN00000007		
REV. LTR: E	VERSION: 01	TDR: 000001099922
FILE: \AAA\00005\141	REVISED: 10:24:49 02/19/2019	BY: ENBRIRO
MTL: -	© □	

BALDOR - RELIANCE®

3PH, SV, 3 LEADS, WYE OR DELTA CONNECTED

SH 1 of 1