

BALDOR • RELIANCE

Customer information packet

EM3313T-5BG

10HP, 1770RPM, 3PH, 60HZ, 215T, 3740M, OPSB, F1

Class - None

Division - Not Applicable

Specifications

Enclosure	OPSB
Frame	215T
Frame Material	Steel
Frequency	60.00 Hz
Haz Area Class and Group	None
Haz Area Division	Not Applicable
Motor Letter Type	Three Phase
Output @ Frequency	10.000 HP @ 60 HZ
Phase	3
Synchronous Speed @ Frequency	1800 RPM @ 60 HZ
Voltage @ Frequency	575.0 V @ 60 HZ
Agency Approvals	UR CSA CSA EEV
Ambient Temperature	40 °C
Auxillary Box	No Auxillary Box
Auxillary Box Lead Termination	None
Base Indicator	Rigid
Bearing Grease Type	Polyrex EM (-20F +300F)
Blower	None
Current @ Voltage	10.000 A @ 575.0 V
Design Code	B
Drip Cover	No Drip Cover
Duty Rating	CONT
Efficiency @ 100% Load	91.7 %
Electrically Isolated Bearing	Not Electrically Isolated
Feedback Device	NO FEEDBACK
Front Face Code	Standard
Front Shaft Indicator	None
Heater Indicator	No Heater
High Voltage Full Load Amps	10.0 a
Insulation Class	H

Part detail

Revision	M
Type	AC
Mech. spec.	37N346
Base	
Status	PRD/A
Elec. spec.	37WGT932
Layout	37LYN346
Eff. date	05-14-2024
CD Diagram	CD0006
Poles	04
Leads	3#14
Proprietary	False
Created date	09-22-2014

Inverter Code	Inverter Ready
KVA Code	H
Lifting Lugs	Standard Lifting Lugs
Locked Bearing Indicator	Locked Bearing
Motor Lead Exit	Ko Box
Motor Lead Quantity/Wire Size	3 @ 14 AWG
Motor Lead Termination	Flying Leads
Motor Standards	NEMA
Motor Type	3740M
Mounting Arrangement	F1
Number of Poles	4
Overall Length	17.45 IN
Power Factor	82
Product Family	General Purpose
Pulley End Bearing Type	Ball
Pulley Face Code	Standard
Pulley Shaft Indicator	Standard
Rodent Screen	None
Service Factor	1.15
Shaft Diameter	1.375 IN
Shaft Extension Location	Pulley End
Shaft Ground Indicator	Shaft Grounding
Shaft Rotation	Reversible
Shaft Slinger Indicator	No Slinger
Speed	1770 rpm
Speed Code	Single Speed
Starting Method	Direct on line
Thermal Device - Bearing	None
Thermal Device - Winding	None
Vibration Sensor Indicator	No Vibration Sensor
Winding Thermal 1	None
Winding Thermal 2	None

Nameplate

NP1259L									
CAT.NO.	EM3313T-5BG								
SPEC.	37N346T932G1								
HP	10								
VOLTS	575								
AMP	10								
RPM	1770								
FRAME	215T		HZ	60		PH	3		
SER.F.	1.15	CODE	H	DES	B	CL	H		
NEMA-NOM-EFF	91.7	PF	82						
RATING	40C AMB-CONT								
CC	010A								
DE	6307		ODE	6206					
ENCL	OPSB	SN							

Parts list

Part number	Description	Quantity
SA287458	SA 37N346T932G1	1.000 ea
RA273671	RA 37N346T932G1	1.000 ea
HA6361A01	LIFTING LUG FOR 37, 39 & 40 FRAME ZINC	2.000 ea
37CB3006	37 CB CASTING W/1.38 LEAD HOLE @ 6:00	1.000 ea
51XW2520A10	.25-20 X .62, TAPTITE II, HEX WSHR SLTD	2.000 ea
11XW1032G06	10-32 X .38, TAPTITE II, HEX WSHR SLTD U	1.000 ea
37EP3203A00	MASTER,ODE,206 BRG,GREASER	1.000 ea
HW4500A01	1641B(ALEMITE)400 UNIV, GREASE FITT	1.000 ea
HW5100A06	W2420-025 WVY WSHR (WB)	1.000 ea
37EP3204B00	MASTER,DE,307 BRG,GREASER,LOCKED BEARING	1.000 ea
10XN2520A28	1/4-20X 1 3/4 HEX HD	4.000 ea
HW1001A25	LOCKWASHER 1/4, ZINC PLT .493 OD, .255 I	4.000 ea
HW4500A01	1641B(ALEMITE)400 UNIV, GREASE FITT	1.000 ea
XY3118A12	5/16-18 HEX NUT DIRECTIONAL SERRATION	4.000 ea
37CB4516	LIPPED LID FOR 37 FRAME NEC KOBX	1.000 ea
51XW0832A07	8-32 X .44, TAPTITE II, HEX WSHR SLTD SE	4.000 ea
HW2501F21	KEY, 5/16 SQ X 2.375	1.000 ea
HA7000A02	KEY RETAINER RING, 1 1/8 DIA, 1 3/8 DIA	1.000 ea
85XU0407S04	4X1/4 U DRIVE PIN STAINLESS	2.000 ea
LB1508	LABEL "SHAFT GROUNDING BRUSH" 1.50 X .81	1.000 ea
MJ1000A02	GREASE, POLYREX EM EXXON	0.050 lb
MG1050Y01	CELEROL BALDOR GOLD *** NLA IN 5 GALLON	0.028 ga
HA3104A35	THRUBOLT .31-18 X 13.687	4.000 ea
37AD2001A01	BAFFLE PLATE, PLASTIC 0.63" WIDTH	2.000 ea
LC0006	CONNECTION LABEL	1.000 ea
MN416A01	TAG-INSTAL-MAINT no wire (2500bx)4/22	1.000 ea
NP1259L	ALUM SUPER-E UL CC NEMA PREMIUM A60	1.000 ea
37PA1074	PALLET PACK GRP, PRINT BOX PK1026A06	1.000 ea
PE-0000001	ZRTG PE ASSEMBLY	1.000 ea
FE-0000001	ZRTG FE ASSEMBLY	1.000 ea
LB1624	COMBINED WARNING LABEL, ISO/ANSI PICTOGR	1.000 ea

AC Induction Motor Performance Data

Record # 50487

Typical performance - not guaranteed values

Winding: 37WGT932-R005		Type: 3740M	Enclosure: OPSB		
Nameplate Data			575 V, 60 Hz: Single Voltage Motor		
Rated Output (HP)	10	Full Load Torque	29.68 LB-FT		
Volts	575	Start Configuration	direct on line		
Full Load Amps	10	Breakdown Torque	87.58 LB-FT		
R.P.M.	1770	Pull-up Torque	46.92 LB-FT		
Hz	60 Phase	3	Locked-rotor Torque	52.43 LB-FT	
NEMA Design Code	B	KVA Code	H	Starting Current	71.77 A
Service Factor (S.F.)	1.15	No-load Current	4.43 A		
NEMA Nom. Eff.	91.7	Power Factor	82	Line-line Res. @ 25°C	1.71 Ω
Rating - Duty	40C AMB-CONT		Temp. Rise @ Rated Load	34°C	
S.F. Amps			Temp. Rise @ S.F. Load	41°C	
			Locked-rotor Power Factor	37.7	
			Rotor inertia	0.984 LB-FT ²	

Load Characteristics 575 V, 60 Hz, 10 HP

% of Rated Load	25	50	75	100	125	150	S.F.
Power Factor	43	66	77	82	85	85	84
Efficiency	87	91.7	92.2	91.7	90.9	89.8	91.2
Speed	1793	1785	1777	1770	1760	1750	1763
Line amperes	4.94	6.26	7.96	10	12.18	14.77	11.3

ABB Motors and Mechanical Inc.

WINDING # 37WGT932

Typical performance - not guaranteed values.

10 HP 3 PH 60 HZ 1770 RPM 575 V 3740M

TORQUES (LB-FT): PO=87.58 PU=46.92 LR=52.43 LRA=71.77

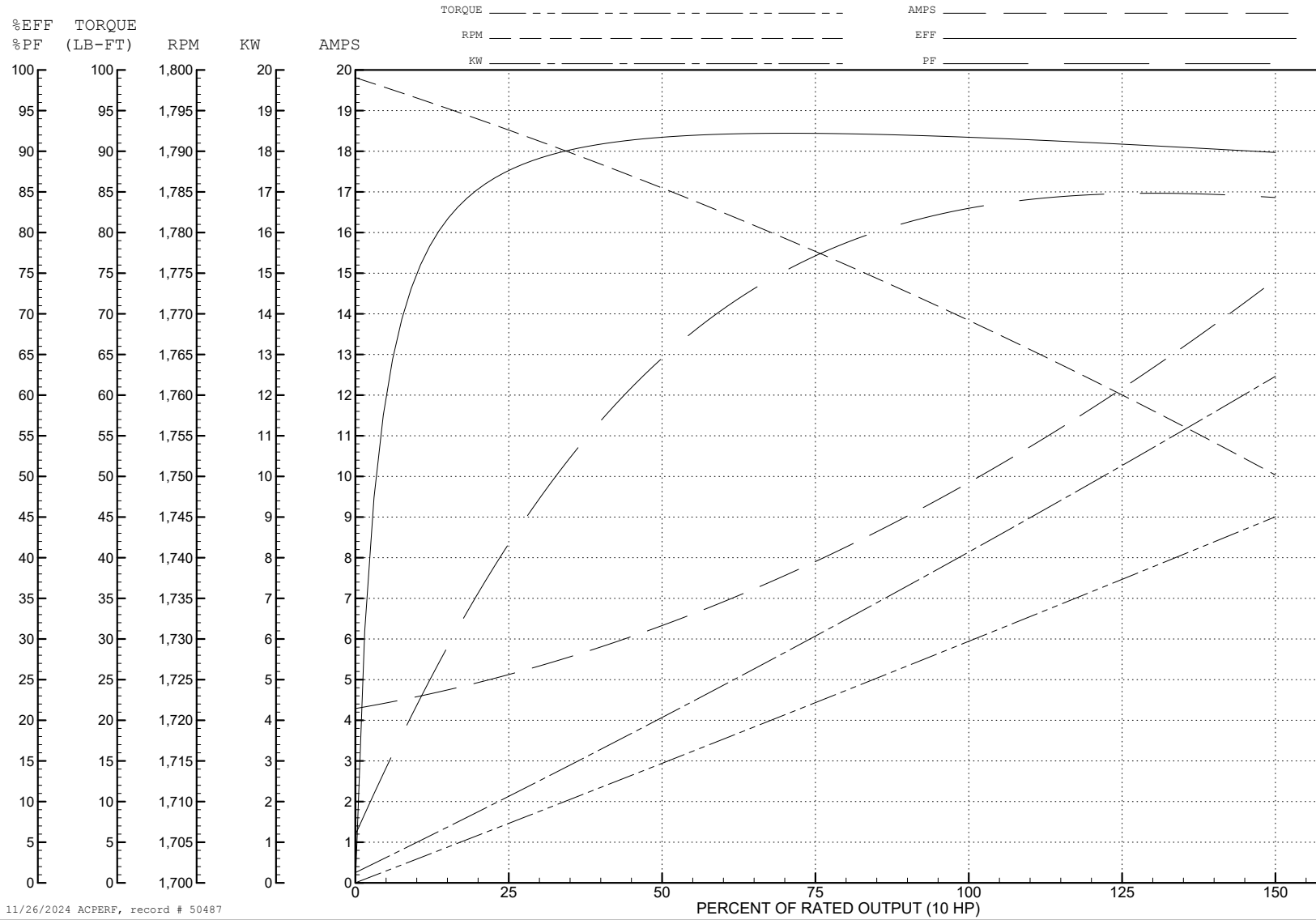

11/26/2024 ACPERF, record # 50487

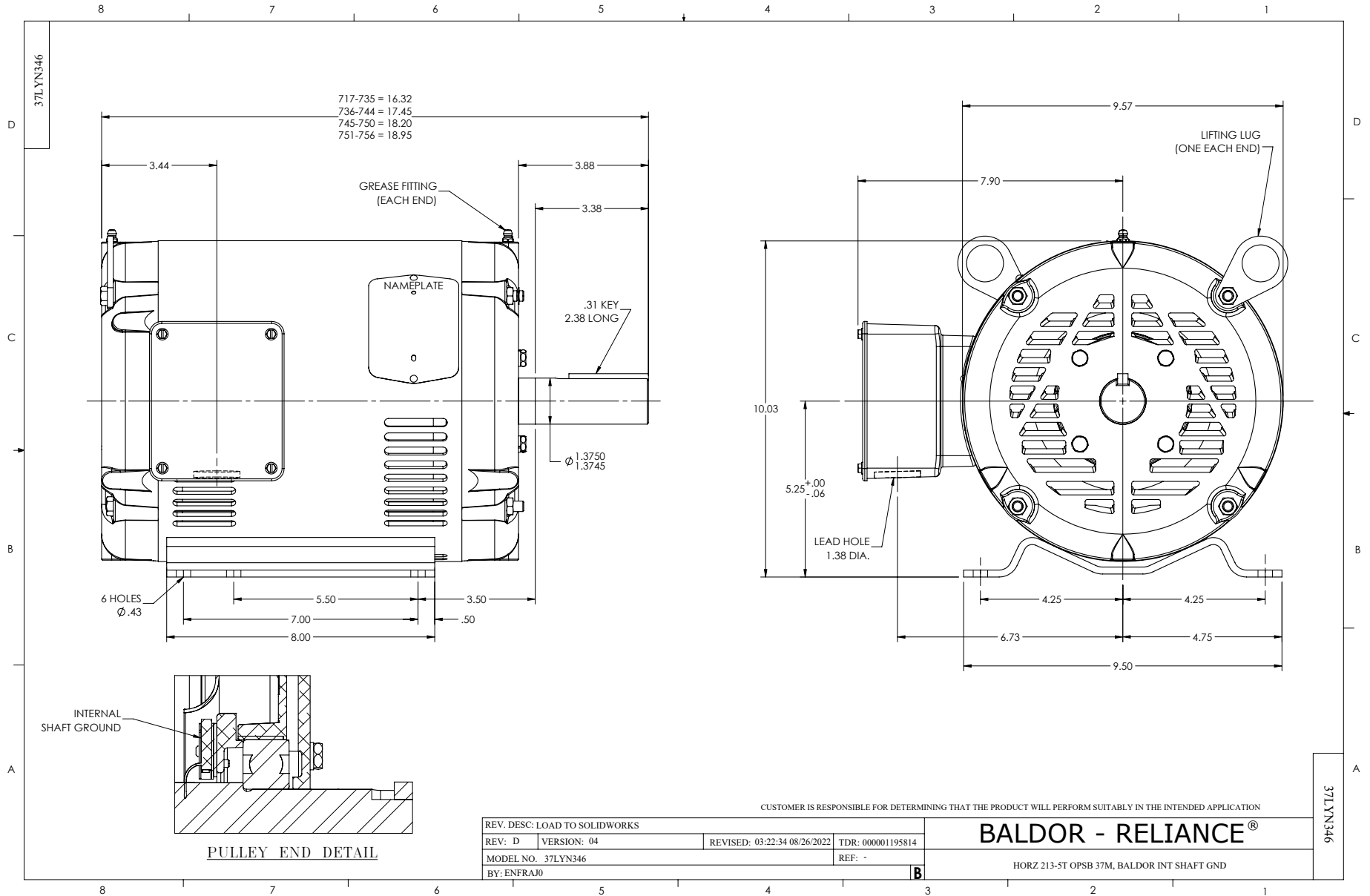

CD0006

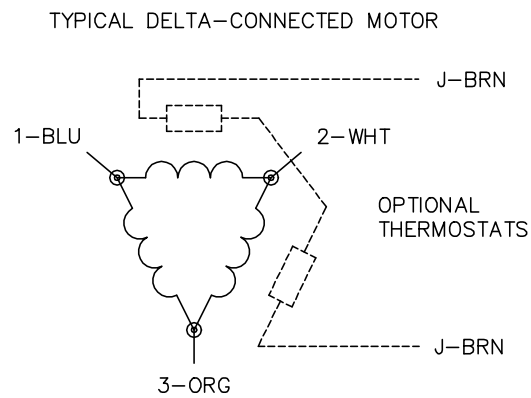
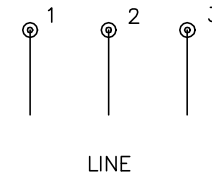
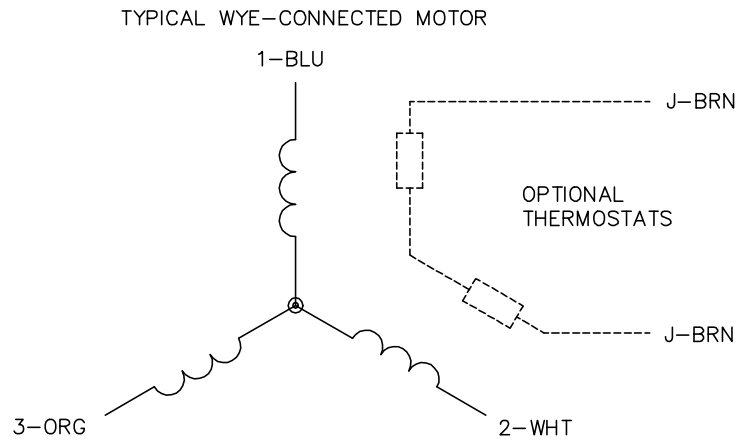

NOTES:

1. THREE LEAD MOTOR MAY BE EITHER WYE CONNECTED OR DELTA CONNECTED.
2. INTERCHANGE ANY TWO LINE LEADS TO REVERSE ROTATION.
3. OPTIONAL THERMOSTATS ARE PROVIDED WHEN SPECIFIED.
4. ACTUAL NUMBER OF INTERNAL PARALLEL CIRCUITS MAY VARY.
5. LEAD COLORS ARE OPTIONAL. LEADS MUST BE NUMBERED AS SHOWN.

CD0006

REV. DESC: ADD CLASS CONN00000007		
REV. LTR: E	VERSION: 01	TDR: 000001099922
FILE: \AAA\00005\141	REVISED: 10:24:49 02/19/2019	BY: ENBRIRO
MTL: -	© □	

BALDOR - RELIANCE®

3PH, SV, 3 LEADS, WYE OR DELTA CONNECTED

SH 1 of 1