



Customer information packet

EM4400T

100HP, 1785RPM, 3PH, 60HZ, 405T, A40064M, TEFC

Class - None

Division - Not Applicable

Specifications

Enclosure	TEFC
Frame	405T
Frame Material	Iron
Frequency	60.00 Hz
Haz Area Class and Group	None
Haz Area Division	Not Applicable
Motor Letter Type	Three Phase
Output @ Frequency	100.000 HP @ 60 HZ
Phase	3
Synchronous Speed @ Frequency	1800 RPM @ 60 HZ
Voltage @ Frequency	230.0 V @ 60 HZ 460.0 V @ 60 HZ
Agency Approvals	CCSAUSEEV
Ambient Temperature	40 °C
Auxillary Box	No Auxillary Box
Base Indicator	Rigid
Bearing Grease Type	Polyrex EM (-20F +300F)
Current @ Voltage	112.000 A @ 460.0 V 224.000 A @ 230.0 V
Design Code	B
Drip Cover	No Drip Cover
Duty Rating	CONT
Efficiency @ 100% Load	95.4 %
Feedback Device	NO FEEDBACK
Heater Indicator	No Heater
High Voltage Full Load Amps	112.0 a
Insulation Class	F
Inverter Code	Inverter Ready
KVA Code	G
Lifting Lugs	Standard Lifting Lugs
Motor Lead Quantity/Wire Size	3 @ 2 AWG
Motor Standards	NEMA

Part detail

Revision	T
Type	AC
Mech. spec.	
Base	
Status	PRD/A
Elec. spec.	A40WG0251
Layout	617429-001
Eff. date	09-04-2024
CD Diagram	416820-002
Poles	04
Leads	3#2,6#4
Proprietary	False
Created date	07-16-2013

Motor Type	A40064M
Mounting Arrangement	F1
Number of Poles	4
Overall Length	38.04 IN
Power Factor	87
Pulley End Bearing Type	Ball
Pulley Face Code	Standard
Service Factor	1.15
Shaft Diameter	2.875 IN
Shaft Ground Indicator	No Shaft Grounding
Shaft Rotation	Reversible
Shaft Slinger Indicator	No Slinger
Speed	1785 rpm
Speed Code	Single Speed
Starting Method	Direct on line
Thermal Device - Bearing	None
Thermal Device - Winding	None

Nameplate

NP2349L

SPEC NO.	P40G3923	CAT.NO.	EM4400T	FRAME	405T
HP	100	VOLTS	230/460	PHASE	3
RPM	1785	AMPS	224/112	HZ	60
DRIVE END BEARING	80BC03J30X	DUTY	CONT	INSUL.CLASS	F
OPP D.E. BEARING	80BC03J30X	ENCL	TEFC	CODE	G
SER.NO.		POWER FACTOR	87	NEMA-NOM-EFFICIENCY	95.4
				MAX CORR KVAR	18
				GUARANTEED EFFICIENCY	94.5
				NEMA NOM/CSA QUOTED EFF	
				MOTOR WEIGHT	

Parts list

Part number	Description	Quantity
SA267712	SA P40G3923	1.000 ea
RA254382	RA P40G3923	1.000 ea
000613006PU	N/P (RELEASE QTY 10,000) UL CSA LABEL	1.000 ea
000692000VD	LABEL WARNING	1.000 ea
000692000FF	N/P	1.000 ea
NP2349L	SUPER-E ,SS, CURUS EEV, CC, LASER	1.000 ea
421948032	LABEL, MYLAR	1.000 ea
412118006A	DRAIN	2.000 ea
004824015A	GREASE POLYREX EM	0.884 lb
032018008CK	HHCS 3/8-16X1L PLATED	4.000 ea
032018008CK	HHCS 3/8-16X1L PLATED	4.000 ea
032018020EK	HHCS 5/8-11X2-1/2 PLTD.	4.000 ea
032018026CK	HHCS 3/8-16X3-1/4 PLTD.	3.000 ea
034000014AB	WSH ID.406 OD.812 TH.065	4.000 ea
034180012DA	KEY 1X4X1/4X1-1/2 L	1.000 ea
034530060AB	P/NIP 1/8X7-1/2 GALV.	1.000 ea
034530056BB	P/NIP 1/4X7 SCHED 40	1.000 ea
034692005AA	P PLUG 3/4"BLK.	1.000 ea
034690001AB	1/8" NPT SQHDPLG	1.000 ea
034631002AB	BUSH 1/4 TO 1/8 PLTD.	1.000 ea
078548001R	FAN KB 234/150 (84) 400	1.000 ea
083198127A	G400 MOLDED FAN COVER	1.000 ea
089412501A	BRKT FTMT G400 FIN MACH 6316 89412500WCA	1.000 ea
415045002B	SLGR	1.000 ea
410700000DA	WAVY SPRING WASHER	1.000 ea
415072001B	CLAMP	1.000 ea
415096002A	CPLG 1/8 HEX TYPE	1.000 ea
032018020EK	HHCS 5/8-11X2-1/2 PLTD.	4.000 ea
032018026CK	HHCS 3/8-16X3-1/4 PLTD.	3.000 ea
034690002AB	PPLG 1/4" PLTD.	1.000 ea
089412501A	BRKT FTMT G400 FIN MACH 6316 89412500WCA	1.000 ea

415045002B	SLGR	1.000 ea
032018005AK	HHCS 1/4-20X5/8 PLATED	4.000 ea
035000001A	ALFTG 1/8" 1610-BL	1.000 ea
035000001A	ALFTG 1/8" 1610-BL	1.000 ea
043292000AJ	GASK 320-400	1.000 ea
077176000L	C/BOX, PAINTED 440	1.000 ea
077176001A	CBOXC, PAINTED 360-400	1.000 ea
402731001A	GASK 360-440	1.000 ea
406099000A	PLUG - FAN COVER 320-440	1.000 ea
415000115H	T/LUG #2AWG-4/0AWG	1.000 ea
418150003A	GREASE FITTING CAP	1.000 ea
MG1025Y17	WILKOFAS, 789.701, SUPER E PEARL GOLD	0.375 ga
418150003A	GREASE FITTING CAP	1.000 ea
033775004EA	DRSCR #6-1/4 304 S.S.	2.000 ea
034180044JA	KEY 3/4X3/4X5-1/2 L	1.000 ea
032018005DL	1/2-13 X 5/8 SILICON BRONZE HHCS	1.000 ea
604797045	STD. 400 FRAME SKID	1.000 ea

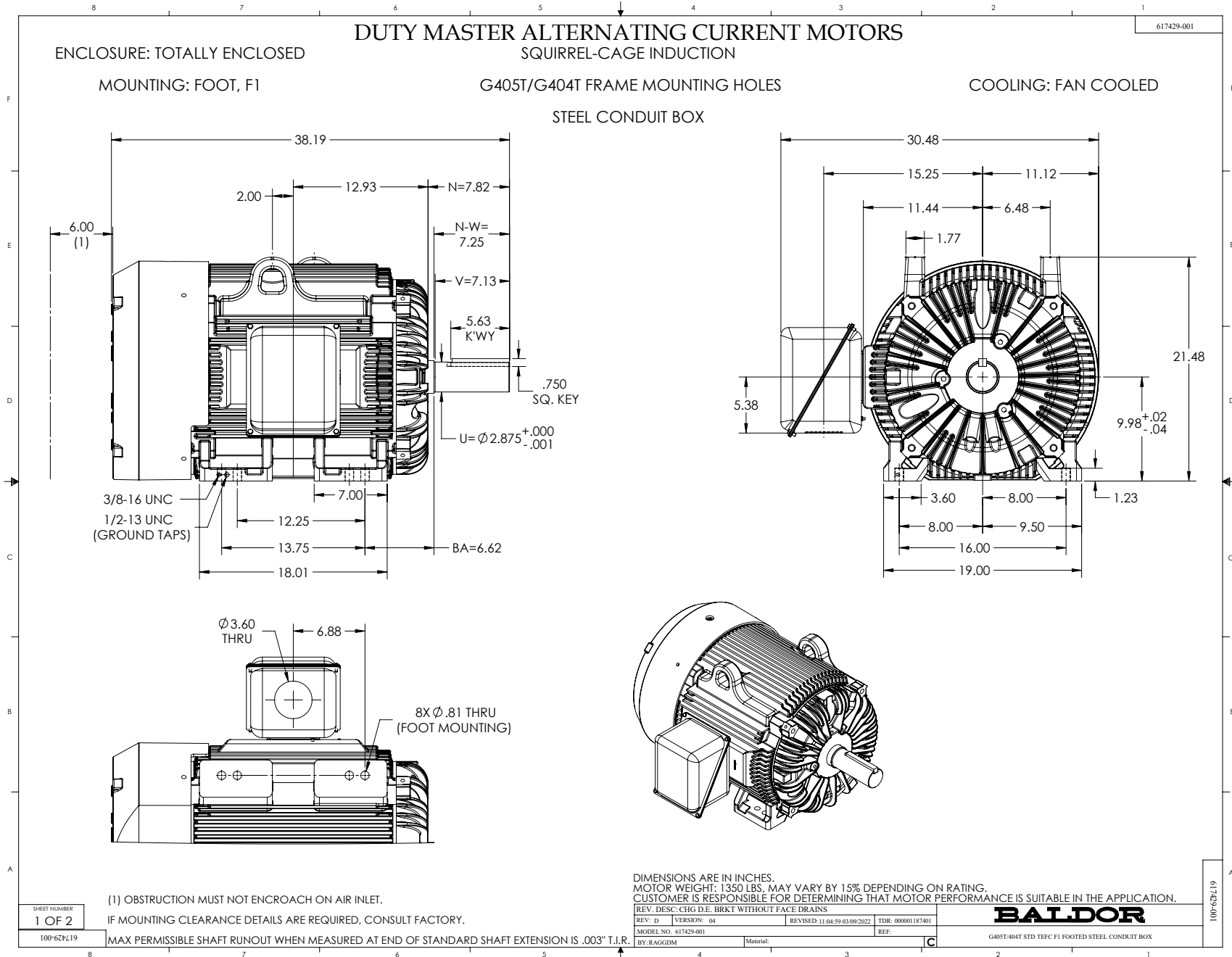

617429-001

DUTY MASTER ALTERNATING CURRENT MOTORS SQUIRREL-CAGE INDUCTION

ENCLOSURE: TOTALLY ENCLOSED

MOUNTING: FOOT, F1

G405T/G404T FRAME MOUNTING HOLES

COOLING: FAN COOLED

STEEL CONDUIT BOX

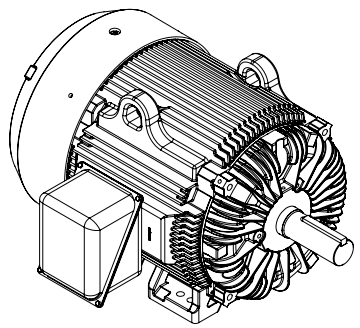
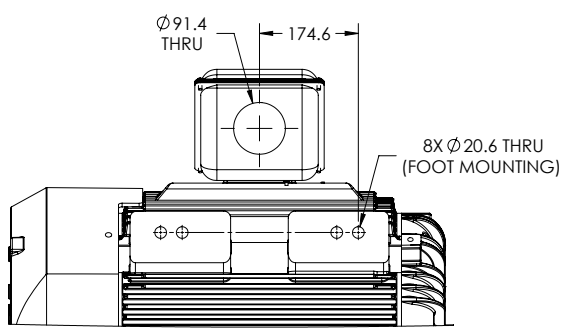
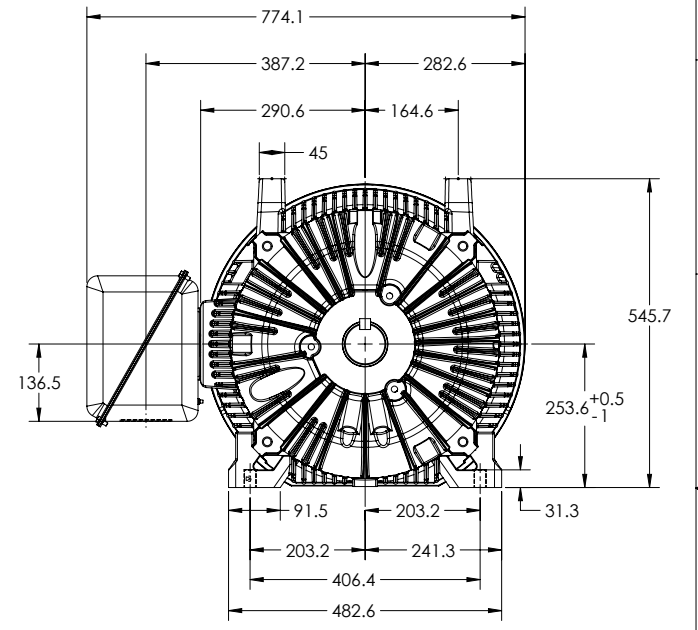
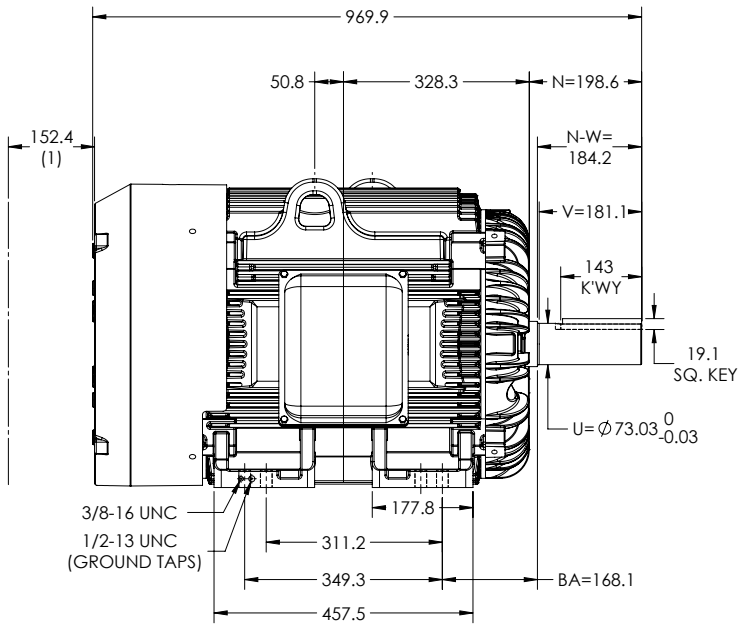

(1) OBSTRUCTION MUST NOT ENCROACH ON AIR INLET.
IF MOUNTING CLEARANCE DETAILS ARE REQUIRED, CONSULT FACTORY.

SHEET NUMBER
2 OF 2

100-627219 MAX PERMISSIBLE SHAFT RUNOUT WHEN MEASURED AT END OF STANDARD SHAFT EXTENSION IS .08 T.I.R.

DIMENSIONS ARE IN MILLIMETERS.
MOTOR WEIGHT: 612, MAY VARY BY 15% DEPENDING ON RATING.
CUSTOMER IS RESPONSIBLE FOR DETERMINING THAT MOTOR PERFORMANCE IS SUITABLE IN THE APPLICATION.

REV: D	VERSION: 04	REVISED: 11-04-59 03:09:2022	TDR: 000001187401
MODEL NO. 617429-001	BY: RAGGDM	Material:	REF:

BALDOR

G405T-404T STD TEFC F1 FOOTED STEEL CONDUIT BOX

617429-001

416820-002

A-C MOTOR
 CONNECTION DIAGRAM
 STANDARD 9 LEAD DELTA-CONNECTED

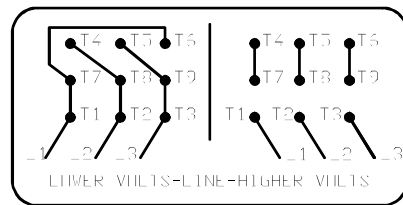
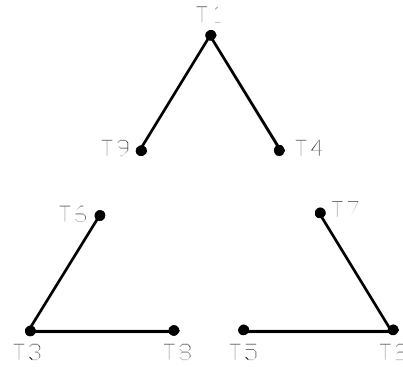

(N.P. 1575-B)

416820-002

REV. DESC: FONT CHANGE FOR PDF SEARCHABLE		
REV. LTR: A	VERSION: 01	TDR: 000001009382
FILE: \MGA\00000\661	REVISED: 02:46:19 02/13/2020	BY: MGHMTT
MTL: -	© □	

BALDOR - RELIANCE®

CONN DIAG - STANDARD 9 LEAD, DELTA-CONNECTED

SH 1 of 1