

BALDOR • RELIANCE

Customer information packet

EWDM4403T

60HP, 1185RPM, 3PH, 60HZ, 404T, TEFC, F1

Class - None

Division - Not Applicable

Specifications

Enclosure	TEFC
Frame	404T
Frame Material	Iron
Frequency	60.00 Hz
Haz Area Class and Group	None
Haz Area Division	Not Applicable
Motor Letter Type	Three Phase
Output @ Frequency	60.000 HP @ 60 HZ
Phase	3
Synchronous Speed @ Frequency	1200 RPM @ 60 HZ
Voltage @ Frequency	230.0 V @ 60 HZ 460.0 V @ 60 HZ
Agency Approvals	CSA EEV CCSA US
Ambient Temperature	40 °C
Auxillary Box	No Auxillary Box
Base Indicator	Rigid
Bearing Grease Type	Polyrex EM (-20F +300F)
Current @ Voltage	139.000 A @ 230.0 V 69.300 A @ 460.0 V
Design Code	B
Drip Cover	No Drip Cover
Duty Rating	CONT
Efficiency @ 100% Load	94.5 %
Enclosure Modification	Severe Duty Features
Feedback Device	NO FEEDBACK
Heater Indicator	No Heater
High Voltage Full Load Amps	69.3 a
Insulation Class	F
Inverter Code	Inverter Ready
IP Rating	IP55
KVA Code	G

Part detail

Revision	A
Type	AC
Mech. spec.	
Base	
Status	PRD/A
Elec. spec.	A40WG0844
Layout	617429-533
Eff. date	10-22-2021
CD Diagram	416820-002
Poles	06
Leads	3#4,6#6
Proprietary	False
Created date	09-11-2019

Motor Lead Quantity/Wire Size	3 @ 4 AWG
Motor Standards	NEMA
Motor Type	A40064M
Mounting Arrangement	F1
Number of Poles	6
Overall Length	38.19 IN
Power Factor	86
Product Family	Washdown Features
Pulley End Bearing Type	Ball
Pulley Face Code	Standard
Service Factor	1.15
Shaft Diameter	2.875 IN
Shaft Ground Indicator	No Shaft Grounding
Shaft Rotation	Reversible
Shaft Slinger Indicator	Shaft Slinger
Speed	1185 rpm
Speed Code	Single Speed
Starting Method	Direct on line
Thermal Device - Bearing	None
Thermal Device - Winding	None

Nameplate

NP2496L	
MOBIL POLYREX EM	

NP2428L

SPEC NO.	A40-7111-0844	CAT.NO.	EWDM4403T	FRAME	404T
HP	60	VOLTS	230/460	PHASE	3
				DESIGN	B
				TYPE	P
RPM	1185	AMPS	139/69.3	HZ	60
				AMB	40
				SF	1.15
DRIVE END BEARING	80BC03JPP30A	DUTY	CONT	INSUL.CLASS	F
OPP D.E. BEARING	80BC03JPP30A	ENCL	TEFC	CODE	G
SER.NO.		POWER FACTOR	86	NEMA-NOM-EFFICIENCY	94.5
				MAX CORR KVAR	12.5
				GUARANTEED EFFICIENCY	93.6
	IP55			NEMA NOM/CSA QUOTED EFF	
	4:1CT AND 4:1VT ON VPWM INVERT		ER, 1.00SF	MOTOR WEIGHT	

Parts list

Part number	Description	Quantity
SA374272	SA A40-7111-0844	1.000 ea
RA364118	RA A40-7111-0844	1.000 ea
421948032	LABEL, MYLAR	1.000 ea
NP2496L	MOTOR LUBE NAMEPLATE	1.000 ea
000613006PU	N/P (RELEASE QTY 10,000) UL CSA LABEL	1.000 ea
000692000CY	N/P	2.000 ea
000692000VD	LABEL WARNING	1.000 ea
NP2428L	WASHDOWN DUTY MOTOR, SS, CC, CSA-C	1.000 ea
412118006A	DRAIN	2.000 ea
034690005AB	PPLG 3/4 PLATED	1.000 ea
089412501A	BRKT FTMT G400 FIN MACH 6316 89412500WCA	1.000 ea
415072001B	CLAMP	1.000 ea
083198101H	G400 STD FAN COVER MACHINING	1.000 ea
034180012DA	KEY 1X4X1/4X1-1/2 L	1.000 ea
078550001H	FAN KB 120/60 360	1.000 ea
004824015A	GREASE POLYREX EM	0.880 lb
032018020EN	HHCS 5/8-11X2-1/2 304SS.	4.000 ea
032018008CN	HHCS 3/8-16X1 304 SS-360	4.000 ea
032018026CN	HHCS 3/8-16X3-1/4 304S.S	3.000 ea
415045002B	SLGR	1.000 ea
410700000DA	WAVY SPRING WASHER	1.000 ea
034001014AF	WSHR 3/8" 304S.S. - 440	4.000 ea
034690001AB	1/8" NPT SQHDPLG	1.000 ea
034690002AB	PPLG 1/4" PLTD.	1.000 ea
034690001AB	1/8" NPT SQHDPLG	1.000 ea
034690002AB	PPLG 1/4" PLTD.	1.000 ea
089412501CH	G400 STD FT MNT BRKT MCHG 6316 BRG WITH	1.000 ea
032018020EN	HHCS 5/8-11X2-1/2 304SS.	4.000 ea
032018026CN	HHCS 3/8-16X3-1/4 304S.S	3.000 ea
415045002B	SLGR	1.000 ea
415028001CH	SEAL - 400	1.000 ea

076708141	CAST IRON 3" LEAD OUTLET	1.000 ea
065776000C	GASKET,MAIN CBOX, 320-400	1.000 ea
076709000A	C/B Cover - 360	1.000 ea
067053000B	GASK 320-400	1.000 ea
032018007AN	HHCS 1/4-20X7/8 304S.S	4.000 ea
032018010CN	HHCS 3/8-16X1-1/4 304S.	4.000 ea
415000115H	T/LUG #2AWG-4/0AWG	1.000 ea
406099000A	PLUG - FAN COVER 320-440	1.000 ea
032018005DL	1/2-13 X 5/8 SILICON BRONZE HHCS	1.000 ea
034000014AB	WSH ID.406 OD.812 TH.065	4.000 ea
004824003AJF	WILKO781.01 WHITE2 COATS - MG1025W01	0.375 ga
033775004EA	DRSCR #6-1/4 304 S.S.	10.000 ea
034180044JA	KEY 3/4X3/4X5-1/2 L	1.000 ea
604797045	STD. 400 FRAME SKID	1.000 ea
032510024D	CARRIAGE BOLT - 444	2.000 ea
034001014AB	FLAT WASHER 3/8"PLATED	2.000 ea
034001016AB	WSHR .562ID 1.375OD .109	2.000 ea
033300014AC	HEX NUT, SHIPPING - 400	2.000 ea
604799003C	PLASTIC BAG 42X32X46	1.000 ea

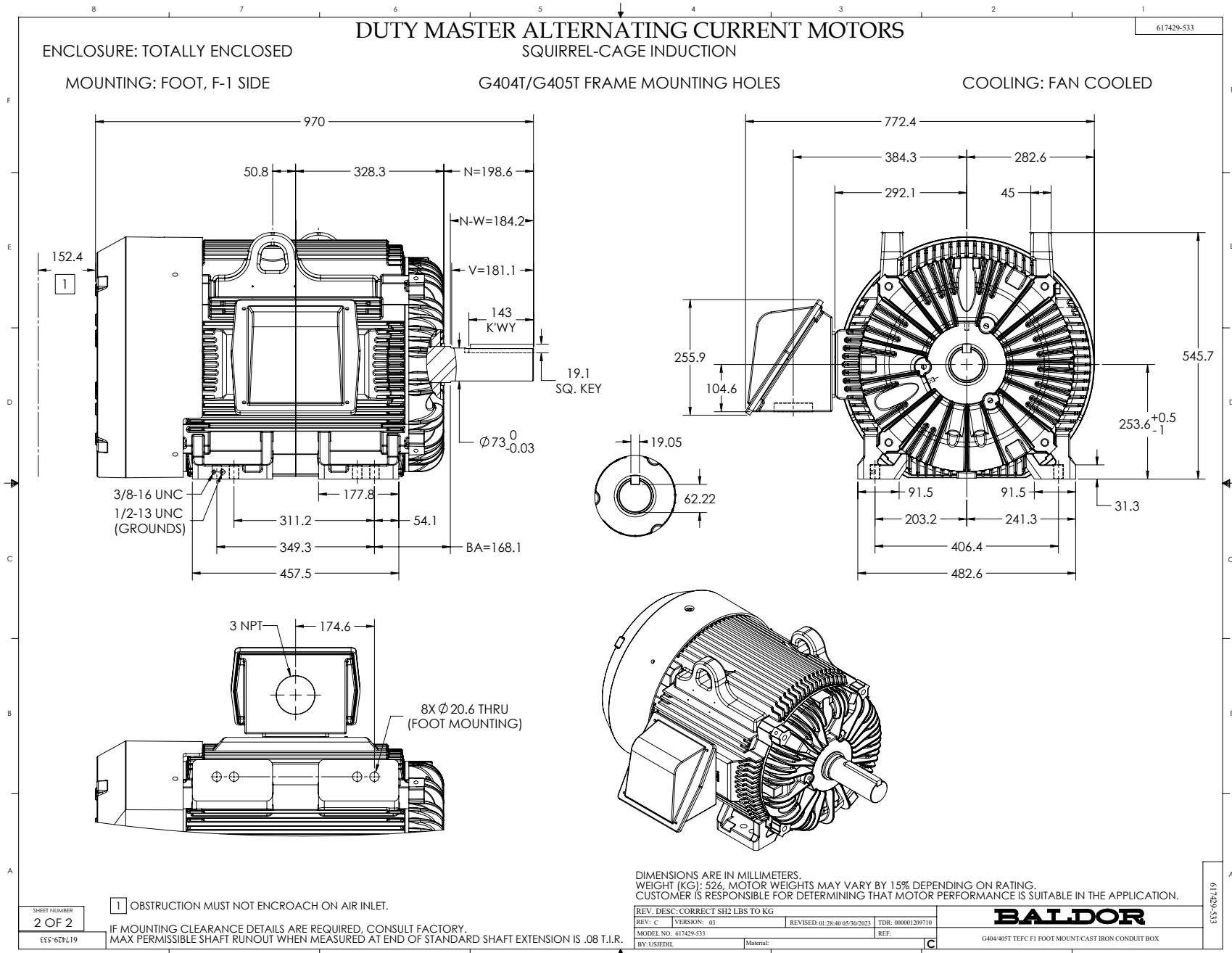

416820-002

A-C MOTOR
 CONNECTION DIAGRAM
 STANDARD 9 LEAD DELTA-CONNECTED

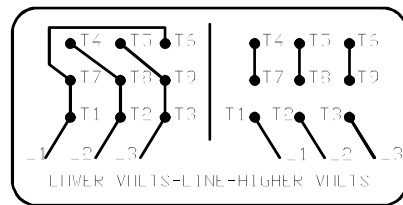
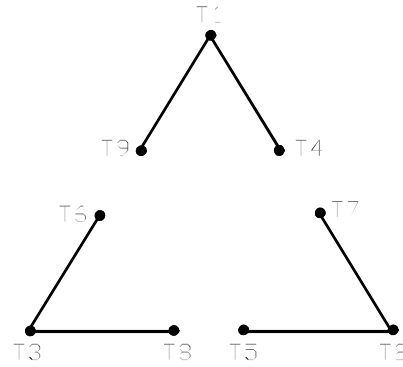

(N.P. 1575-B)

416820-002

REV. DESC: FONT CHANGE FOR PDF SEARCHABLE		
REV. LTR: A	VERSION: 01	TDR: 000001009382
FILE: \MGA\00000\661	REVISED: 02:46:19 02/13/2020	BY: MGHMTT
MTL: -	© □	

BALDOR - RELIANCE®

CONN DIAG - STANDARD 9 LEAD, DELTA-CONNECTED

SH 1 of 1