



Customer information packet

L3514A

1.5HP, 1725RPM, 1PH, 60HZ, 56/56H, 3532LC

Class - None

Division - Not Applicable

Specifications

Enclosure	TEFC
Frame	56/56H
Frame Material	Steel
Frequency	60.00 Hz
Haz Area Class and Group	None
Haz Area Division	Not Applicable
Motor Letter Type	Cap Start, Cap Run
Output @ Frequency	1.500 HP @ 60 HZ
Phase	1
Synchronous Speed @ Frequency	1800 RPM @ 60 HZ
Voltage @ Frequency	115.0 V @ 60 HZ 230.0 V @ 60 HZ
Agency Approvals	UR CSA
Ambient Temperature	40 °C
Auxillary Box	No Auxillary Box
Auxillary Box Lead Termination	None
Base Indicator	Rigid
Bearing Grease Type	Polyrex EM (-20F +300F)
Blower	None
Current @ Voltage	16.000 A @ 115.0 V 7.800 A @ 208.0 V 8.000 A @ 230.0 V
Design Code	L
Drip Cover	No Drip Cover
Duty Rating	CONT
Efficiency @ 100% Load	75.5 %
Electrically Isolated Bearing	Not Electrically Isolated
Feedback Device	NO FEEDBACK
Front Face Code	Standard
Front Shaft Indicator	None
Heater Indicator	No Heater

Part detail

Revision	AL
Type	AC
Mech. spec.	35J385
Base	
Status	PRD/A
Elec. spec.	35WGW159
Layout	35LYJ385
Eff. date	05-14-2024
CD Diagram	CD0016A02
Poles	04
Leads	4#16 A&J,3#18 B PH,1#14 #4TH
Proprietary	False
Created date	01-01-0001

High Voltage Full Load Amps	8.0 a
Insulation Class	F
Inverter Code	Not Inverter
KVA Code	J
Lifting Lugs	No Lifting Lugs
Locked Bearing Indicator	No Locked Bearing
Motor Lead Exit	Ko Box
Motor Lead Quantity/Wire Size	4 @ 16 AWG, A&J
Motor Lead Termination	Flying Leads
Motor Standards	NEMA
Motor Type	3532LC
Mounting Arrangement	F1
Number of Poles	4
Overall Length	13.79 IN
Power Factor	80
Product Family	General Purpose
Pulley End Bearing Type	Ball
Pulley Face Code	Standard
Pulley Shaft Indicator	Standard
Rodent Screen	None
Service Factor	1.00
Shaft Diameter	0.625 IN
Shaft Extension Location	Pulley End
Shaft Ground Indicator	No Shaft Grounding
Shaft Rotation	Reversible
Shaft Slinger Indicator	No Slinger
Speed	1725 rpm
Speed Code	Single Speed
Starting Method	Direct on line
Thermal Device - Bearing	None
Thermal Device - Winding	Do Not Use Eve-Not Valid
Vibration Sensor Indicator	No Vibration Sensor
Winding Thermal 1	Automatic Thermal Overload
Winding Thermal 1 Location	SB

Winding Thermal 2

None

Nameplate

NP1257L									
CAT.NO.	L3514A								
SPEC.	35J385W159								
HP	1.5								
VOLTS	115/230								
AMP	16/8								
RPM	1725								
FRAME	56/56H		HZ	60		PH	1		
SER.F.	1.00	CODE	J	DES	L	CL	F		
NEMA-NOM-EFF	75.5	PF	80						
RATING	40C AMB-CONT								
CC									
DE	6205	ODE	6203						
ENCL	TEFC	SN							

Parts list

Part number	Description	Quantity
SA025963	SA 35J385W159	1.000 ea
RA022013	RA 35J385W159	1.000 ea
OC3015F12SP	CYL OIL CAP 15MFD/370V	1.000 ea
EC1645A06SP	ELEC CAP, 645-774 MFD, 125V, 2.06D X 4.	1.000 ea
TP5059	GENERIC WELDED THERMAL, 7" LEAD KIT	1.000 ea
NS2512A01	INSULATOR, CONDUIT BOX X	1.000 ea
35CB3007	35 CB CASTING W/.88 DIA. LEAD HOLE	1.000 ea
36GS1000SP	GASKET-CONDUIT BOX, .06 THICK #SV-330 LE	1.000 ea
51XB1016A07	10-16 X 7/16 HXWSSLD SERTYB	2.000 ea
11XW1032G06	10-32 X .38, TAPTITE II, HEX WSHR SLTD U	1.000 ea
35EP3122K00	MASTER ODE,203 BRG,.683SH,#26 DRN,FH MTG	1.000 ea
51XW0832A07	8-32 X .44, TAPTITE II, HEX WSHR SLTD SE	2.000 ea
35CB3801	CAPACITOR COVER, CAST	1.000 ea
34GS3002	GASKET, CAPACITOR BOX	1.000 ea
HA7010	CAPACITOR RETENTION CLAMP	1.000 ea
51XB1016A08	10-16X 1/2HXWSSLD SERTYB	2.000 ea
NS2501A02	INSULATOR, CAPACITOR BOX	1.000 ea
HW5100A03	WAVY WASHER (W1543-017)	1.000 ea
35EP3123A00	MASTER DE,205 BRG,.998SH,#26 DRN	1.000 ea
XY1032A02	10-32 HEX NUT DIRECTIONAL SERRATION	4.000 ea
35FN3002A05SP	EXFN, PLASTIC, 6.376 OD, .638 ID	1.000 ea
MG1050G01	CELEROL MEDIUM CHARCOAL METALLIC GRAY	0.017 ga
51XB1214A16	12-14X1.00 HXWSSLD SERTYB	1.000 ea
35FH4005A32SP	IEC FH NO GRSR W/3 HOLES - PRIMED	1.000 ea
51XW1032A06	10-32 X .38, TAPTITE II, HEX WSHR SLTD S	3.000 ea
35CB4521GX	CONDUIT BOX LID KIT **ORDER INDIV PARTS	1.000 ea
51XW0832A07	8-32 X .44, TAPTITE II, HEX WSHR SLTD SE	4.000 ea
HW2501D13	KEY, 3/16 SQ X 1.375	1.000 ea
HA7000A04	KEY RETAINER 0.625 DIA SHAFTS	1.000 ea
85XU0407S04	4X1/4 U DRIVE PIN STAINLESS	2.000 ea
WD1000A15	3-520132-2 AMP FLAG (4M/RL NON-CANC/NON-	4.000 ea

MJ1000A02	GREASE, POLYREX EM EXXON	0.050 lb
LC0016	CONNECTION LABEL	1.000 ea
NP1257L	ALUM UL CC THERMAL REV MTG	1.000 ea
HA3100A22	THRUBOLT 10-32 X 10.125	4.000 ea
SP5181A03	MODEL 35 LC TORQ STAT SWITCH LEAD ASSY	1.000 ea
LB1118	LABEL,WARNING (ROLL LABEL)	1.000 ea
35PA1066	PKG GRP, PRINT PK1008A06	1.000 ea
MN416A01	TAG-INSTAL-MAINT no wire (2500bx)4/22	1.000 ea
PE-0000001	ZRTG PE ASSEMBLY	1.000 ea
FE-0000001	ZRTG FE ASSEMBLY	1.000 ea

Accessories

Part number	Description	Multiplier
35-8762	C FACE KIT	A8
35EP1506A01SP	D-FLANGE KIT	A8

AC Induction Motor Performance Data

Record # 61265

Typical performance - not guaranteed values

Winding: 35WGW159-R008		Type: 3532LC		Enclosure: TEFC	
Nameplate Data			230 V, 60 Hz: High Voltage Connection		
Rated Output (HP)	1.5	Full Load Torque	4.5 LB-FT		
Volts	115/230	Start Configuration	direct on line		
Full Load Amps	16/8	Breakdown Torque	14.5 LB-FT		
R.P.M.	1725	Pull-up Torque	11.5 LB-FT		
Hz	60 Phase	1	Locked-rotor Torque	15 LB-FT	
NEMA Design Code	L KVA Code	J	Starting Current	57 A	
Service Factor (S.F.)		1	No-load Current	5.2 A	
NEMA Nom. Eff.	75.5 Power Factor	80	Line-line Res. @ 25°C	1.41 Ω A Ph 1.18 Ω B Ph	
Rating - Duty	40C AMB-CONT		Temp. Rise @ Rated Load	76°C	

Load Characteristics 230 V, 60 Hz, 1.5 HP

% of Rated Load	25	50	75	100	125	150
Power Factor	42	59	72	80	85	88
Efficiency	59.1	71.6	76.1	76.6	75.7	73.4
Speed	1784	1773	1759	1743	1726	1706
Line amperes	5.3	5.9	6.7	7.9	9.4	11

ABB Motors and Mechanical Inc.

WINDING # 35WGW159

Typical performance - not guaranteed values.

1.5 HP 1 PH 60 HZ 1725 RPM 230 V 3532LC

TORQUES (LB-FT): PO=14.5 PU=11.5 LR=15 LRA=57

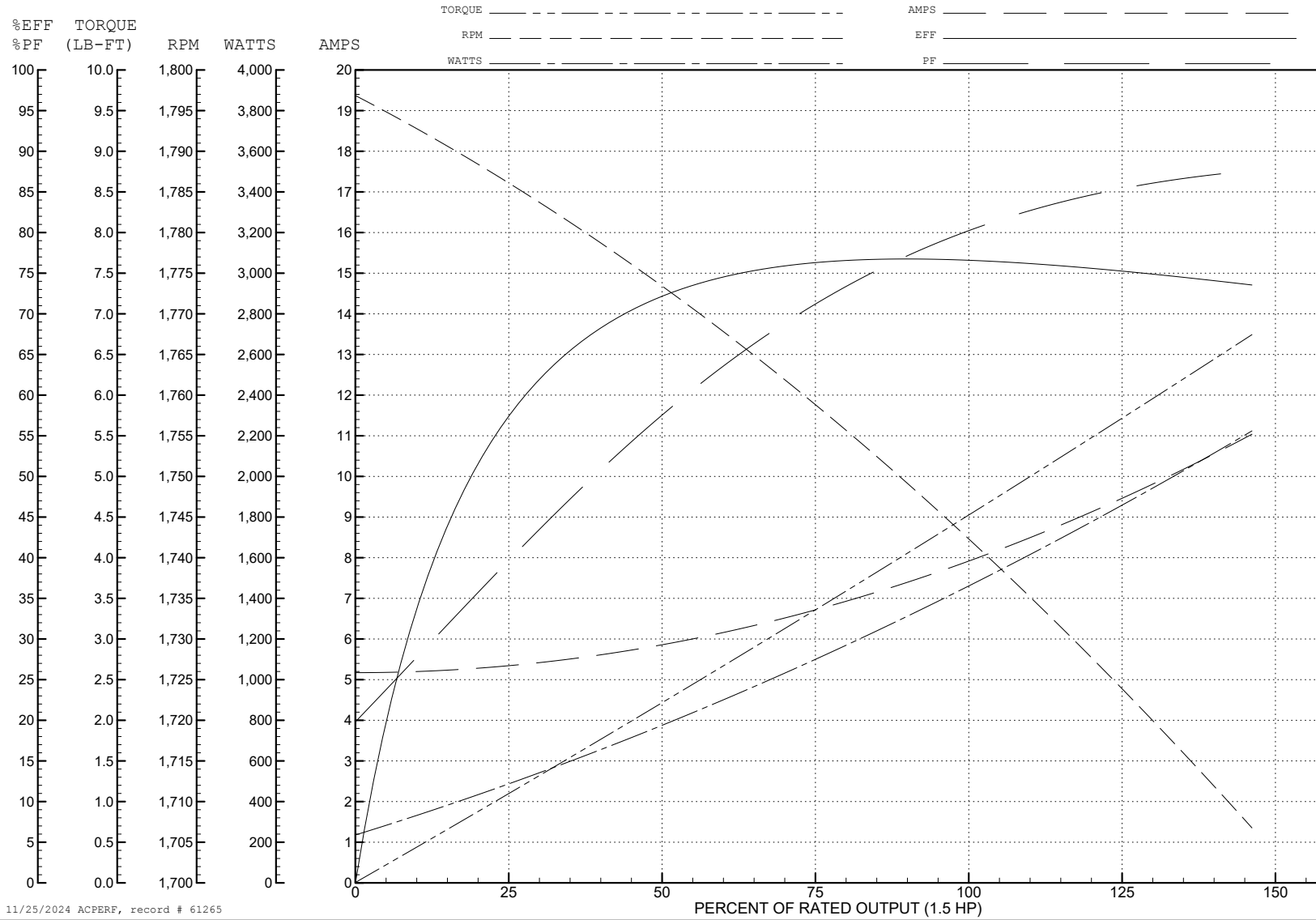

11/25/2024 ACPERF, record # 61265

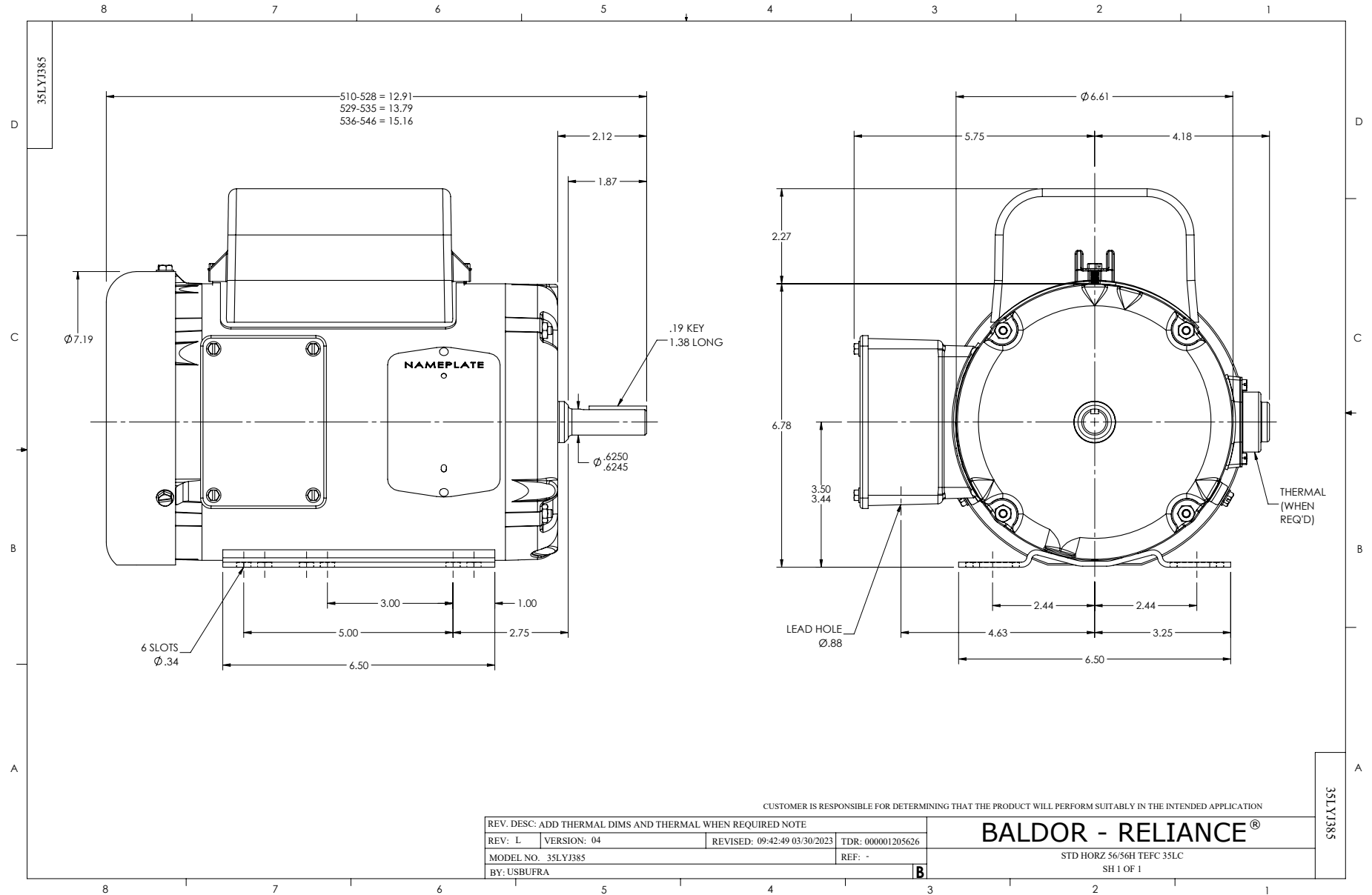

CD0016A02

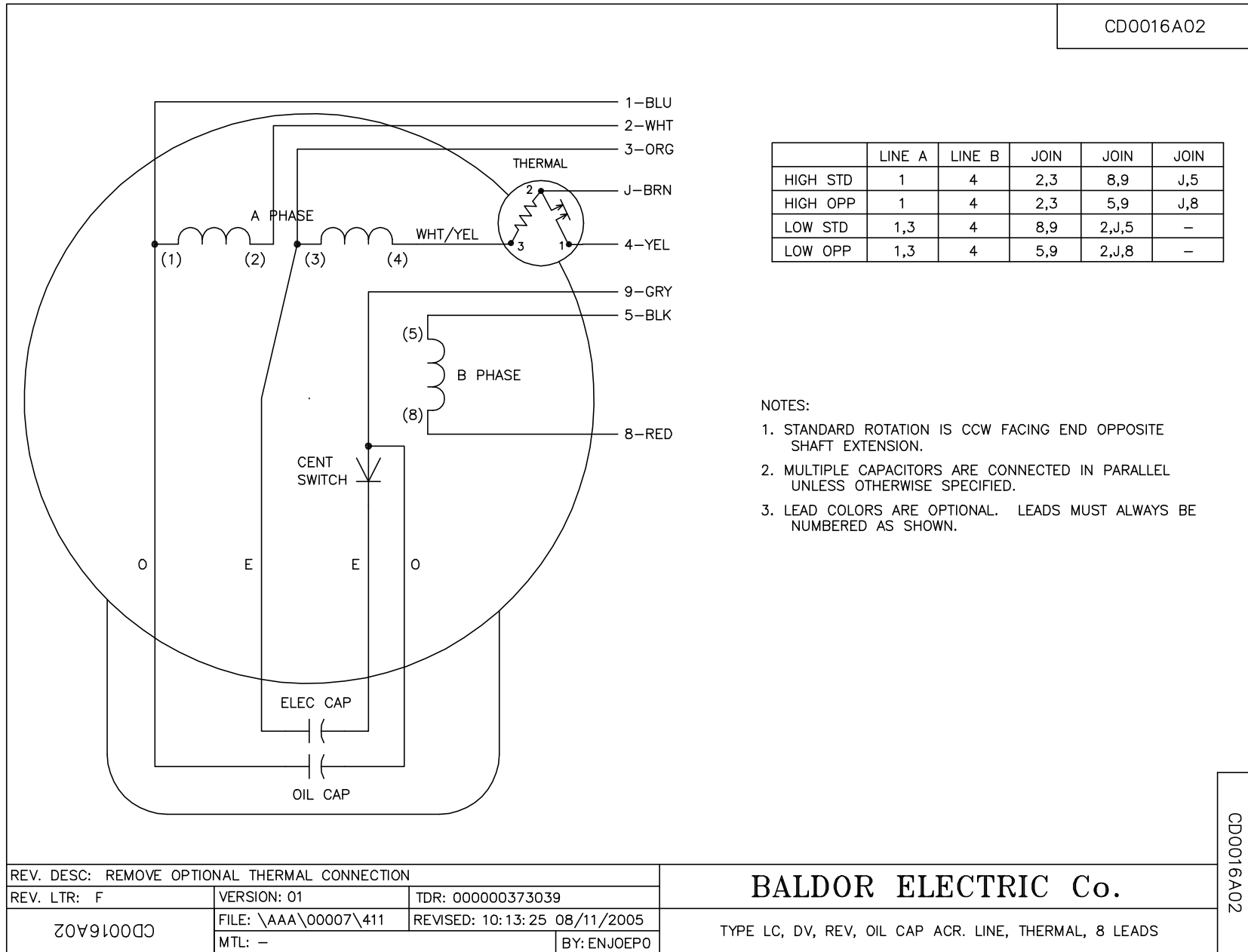

	LINE A	LINE B	JOIN	JOIN	JOIN
HIGH STD	1	4	2,3	8,9	J,5
HIGH OPP	1	4	2,3	5,9	J,8
LOW STD	1,3	4	8,9	2,J,5	-
LOW OPP	1,3	4	5,9	2,J,8	-

NOTES:

1. STANDARD ROTATION IS CCW FACING END OPPOSITE SHAFT EXTENSION.
2. MULTIPLE CAPACITORS ARE CONNECTED IN PARALLEL UNLESS OTHERWISE SPECIFIED.
3. LEAD COLORS ARE OPTIONAL. LEADS MUST ALWAYS BE NUMBERED AS SHOWN.

REV. DESC: REMOVE OPTIONAL THERMAL CONNECTION		
REV. LTR: F	VERSION: 01	TDR: 000000373039
CD0016A02	FILE: \AAA\00007\411	REVISED: 10:13:25 08/11/2005
	MTL: -	BY: ENJOEPO

BALDOR ELECTRIC Co.

TYPE LC, DV, REV, OIL CAP ACR. LINE, THERMAL, 8 LEADS

CD0016A02