

BALDOR • RELIANCE

Customer information packet

VFSWDM3714T-E

10HP, 1770RPM, 3PH, 60HZ, 215TC, TEFC, F1, N

Class - None

Division - Not Applicable

Specifications

Enclosure	TEFC
Frame	215TC
Frame Material	Stainless Steel
Frequency	60.00 Hz
Haz Area Class and Group	None
Haz Area Division	Not Applicable
Motor Letter Type	Three Phase
Output @ Frequency	10.000 HP @ 60 HZ
Phase	3
Synchronous Speed @ Frequency	1800 RPM @ 60 HZ
Voltage @ Frequency	230.0 V @ 60 HZ 460.0 V @ 60 HZ
Agency Approvals	CSA CSA EEV NEMA PREMIUM UR
Ambient Temperature	40 °C
Auxillary Box	No Auxillary Box
Auxillary Box Lead Termination	None
Base Indicator	No Mounting
Bearing Grease Type	Polyrex EM (-20F +300F)
Blower	None
Current @ Voltage	26.700 A @ 208.0 V 25.000 A @ 230.0 V 12.500 A @ 460.0 V
Design Code	B
Drip Cover	No Drip Cover
Duty Rating	CONT
Efficiency @ 100% Load	92.4 %
Electrically Isolated Bearing	Not Electrically Isolated
Feedback Device	NO FEEDBACK
Front Shaft Indicator	None

Part detail

Revision	N
Type	AC
Mech. spec.	37Q227
Base	
Status	PRD/A
Elec. spec.	37WGS251
Layout	37LYQ227
Eff. date	09-22-2023
CD Diagram	CD0180
Poles	04
Leads	9#14
Proprietary	False
Created date	07-10-2017

Heater Indicator	No Heater
High Voltage Full Load Amps	12.5 a
Insulation Class	H
Inverter Code	Inverter Ready
KVA Code	K
Lifting Lugs	Standard Lifting Lugs
Locked Bearing Indicator	Locked Bearing
Motor Lead Quantity/Wire Size	9 @ 14 AWG
Motor Lead Termination	Flying Leads
Motor Standards	NEMA
Motor Type	3756M
Mounting Arrangement	F1
Number of Poles	4
Overall Length	22.12 IN
Power Factor	81
Product Family	WD All SS Encapsulated
Pulley End Bearing Type	Sealed Bearing
Pulley Face Code	C-Face
Pulley Shaft Indicator	Standard
Rodent Screen	None
RoHS Status	ROHS COMPLIANT
Service Factor	1.15
Shaft Diameter	1.375 IN
Shaft Ground Indicator	No Shaft Grounding
Shaft Rotation	Reversible
Shaft Slinger Indicator	No Slinger
Speed	1770 rpm
Speed Code	Single Speed
Starting Method	Direct on line
Thermal Device - Bearing	None
Thermal Device - Winding	None
Vibration Sensor Indicator	No Vibration Sensor
Winding Thermal 1	None
Winding Thermal 2	None

Nameplate

NP4427AAA05

CAT #	VFSWDM3714T-E	LBS						
SPEC	37Q227S251G1	ENCL	TEFC					
SER #		CC	010A	IP	69			
HP	10	MAG CUR	12.6/6.3					
VOLTS	230/460	NEMA NOM. EFF	92.4					
AMPS	25/12.5	PF	81					
RATING	40C AMB-CONT							
RPM	1770	MAX RPM	2700					
FRAME	215TC	HZ	60	CODE	K	CLASS	H	
SER.F.	1.15	SF AMP		PH	3	DES	B	
DE	6307	ODE	6307					
LUBRICATION	POLYREX EM							
ID LOGO	VPWM	CHP	60	TO	90	1.5:1		
ID LOGO	WK2	1.38	CT	15	TO	60	4:1	
ID LOGO	SL HZ	1	VT	6	TO	60	10:1	
YR						QR		

Parts list

Part number	Description	Quantity
SA343547	SA 37Q227S251G1	1.000 ea
RA332007	RA 37Q227S251G1	1.000 ea
37FN3002B01	EXFN, PLASTIC, 7.50 OD, 1.155 ID	1.000 ea
35CB1017B01	37 MID SECT - 3 PC. CONDUIT BOX 1.00 NPT	1.000 ea
RM1070A81	O-RING, -043 VITON/FKM .070CS X 3.489ID	1.000 ea
HA3424S64	STUD - M6X1.0 THDS X 4.00"	1.000 ea
11XW1032G08	10-32 X .50, TAPTITE II, HEX WSHR SLTD U	1.000 ea
HW3001B01	BRASS CUP WASHER, FOR #10 SCREW	1.000 ea
37EP1920A03	FREP, TEFC MACH - 307 BRG WD11/12 (STAIN	1.000 ea
RM1070A48	O-RING, .070 C.S. X 8.656 ID, VITON	1.000 ea
HW4600F35	35 X 52 X 8 LIP SEAL, GRAPHITE INFUSED V	1.000 ea
HW4600F34	35 X 53 X 4.5 AFX SEAL, GRAPHITE INFUSED	1.000 ea
HW4500S33	1/8 NPT STAINLESS #304 SS PLUG	4.000 ea
HW4500S33	1/8 NPT STAINLESS #304 SS PLUG	4.000 ea
HW5100A08	W3118-035 WVY WSHR (WB)	1.000 ea
37EP1925A01	PUEP, MACH - 307 BRG WD11/12 (STAINLESS)	1.000 ea
RM1070A48	O-RING, .070 C.S. X 8.656 ID, VITON	1.000 ea
HW4600F35	35 X 52 X 8 LIP SEAL, GRAPHITE INFUSED V	1.000 ea
HW4600F34	35 X 53 X 4.5 AFX SEAL, GRAPHITE INFUSED	1.000 ea
RM1070A47	O-RING, -011 VITON/FKM .070CS X .301ID	4.000 ea
11XB1214S16	12-14X1.00 HXWSSLD TYP B STAINLESS	1.000 ea
37FH4000A45	STAINLESS FAN COVER, NO GREASER SLOT (FO	1.000 ea
10XN1032FS06	HEX HD CAP SCREW 10-32 X 3/8 SS FOOD SAF	3.000 ea
35CB1513A01	35-36-37 MACH. LID - 3 PC. CONDUIT BOX	1.000 ea
RM1070A81	O-RING, -043 VITON/FKM .070CS X 3.489ID	1.000 ea
HW2502F21	#303 SS,SQ KEY 5/16 X 2.375	1.000 ea
HA7000A02	KEY RETAINER RING, 1 1/8 DIA, 1 3/8 DIA	1.000 ea
MJ5001A27	32220KN GRAY SEALER *MIN BUY 4 QTS=1GAL	0.005 qt
MJ5004A93	FOOD GRADE (H1 RATED) ANTISEIZE THRD COM	0.005 ea
HA1025A21	WSHR,FELT .125" THK	1.000 ea
HA5027A09	DRAIN KIT,(2)HA4002A03 BAGGED W/LABEL	1.000 ea

MJ1000A02	GREASE, POLYREX EM EXXON	0.050 lb
WD5603A01	KIT, CLOSED-END LEAD SPLICE (18-14GA)	1.000 ea
HA3104FS31	THRUBOLT, 5/16-18 X 15.875 SS FOOD SAFE	4.000 ea
37PA1074	PALLET PACK GRP, PRINT BOX PK1026A06	1.000 ea
PK3082	STYROFOAM CRADLE	2.000 ea
MN416A01	TAG-INSTAL-MAINT no wire (2500bx)4/22	1.000 ea
FE-0000016	ZTRG FE ASSEMBLY	1.000 ea
PE-0000010	ZRTG PE ASSEMBLY	1.000 ea

AC Induction Motor Performance Data

Record # 62567

Typical performance - not guaranteed values

Winding: 37WGS251-R016		Type: 3756M		Enclosure: TEFC	
Nameplate Data			460 V, 60 Hz: High Voltage Connection		
Rated Output (HP)	10	Full Load Torque	29.9 LB-FT		
Volts	230/460	Start Configuration	direct on line		
Full Load Amps	25/12.5	Breakdown Torque	102 LB-FT		
R.P.M.	1770	Pull-up Torque	53.6 LB-FT		
Hz	60 Phase	3	Locked-rotor Torque	74.2 LB-FT	
NEMA Design Code	B KVA Code	K	Starting Current	105 A	
Service Factor (S.F.)	1.15	No-load Current	5.44 A		
NEMA Nom. Eff.	92.4 Power Factor	81	Line-line Res. @ 25°C	0.799 Ω	
Rating - Duty	40C AMB-CONT		Temp. Rise @ Rated Load	76°C	
S.F. Amps			Temp. Rise @ S.F. Load	93°C	
			Locked-rotor Power Factor	31.7	
			Rotor inertia	1.38 LB-FT ²	

Load Characteristics 460 V, 60 Hz, 10 HP

% of Rated Load	25	50	75	100	125	150	S.F.
Power Factor	43	65	76	81	83	84	82
Efficiency	88	92.6	93	92.9	92.2	91.5	92.5
Speed	1793	1786	1778	1770	1762	1752	1765
Line amperes	6.18	7.79	10	12.5	15.3	18.3	14.2

ABB Motors and Mechanical Inc.

WINDING # 37WGS251

Typical performance - not guaranteed values.

10 HP 3 PH 60 HZ 1770 RPM 460 V 3756M

TORQUES (LB-FT): PO=102 PU=53.6 LR=74.2 LRA=105

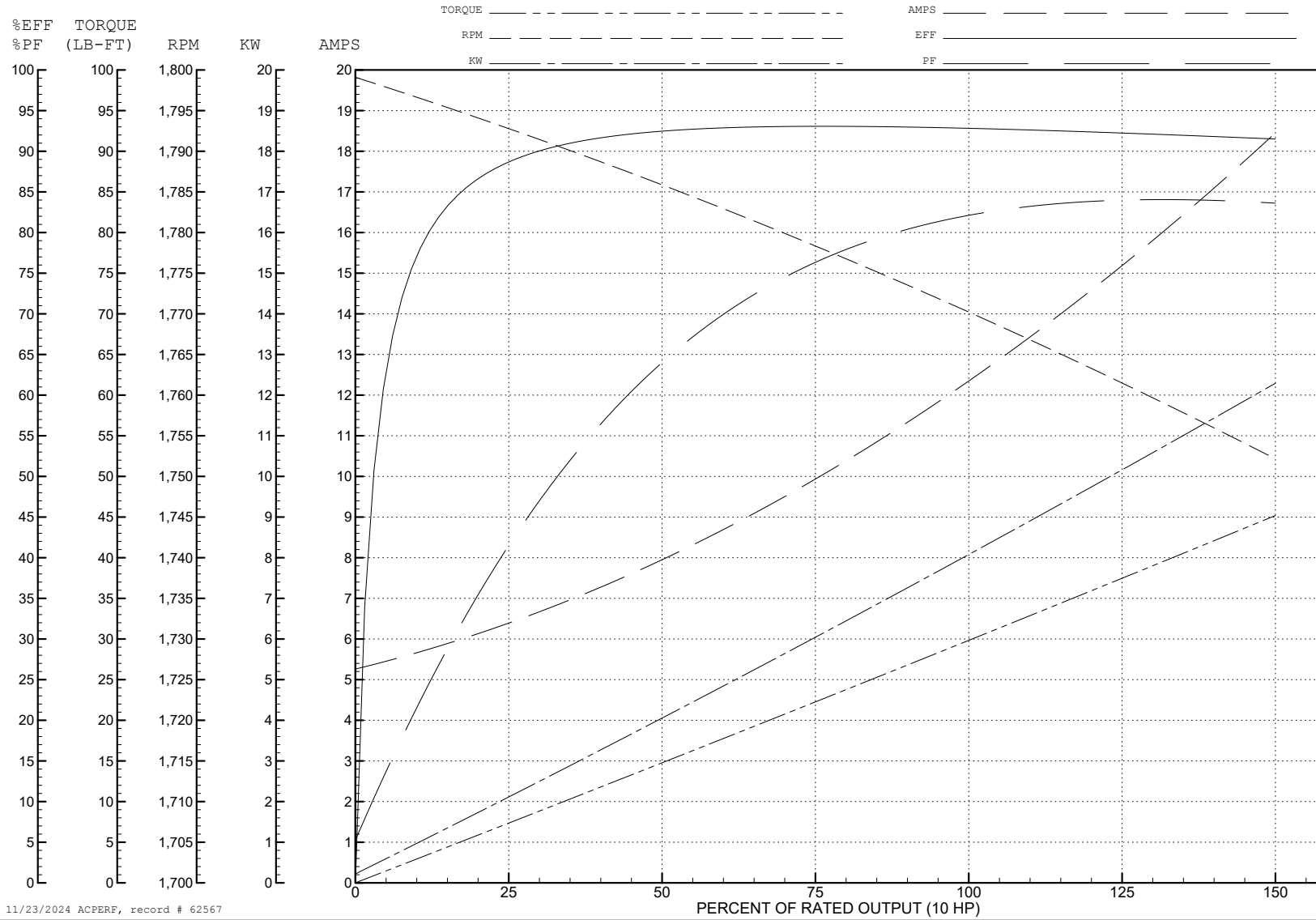

11/23/2024 ACPERF, record # 62567

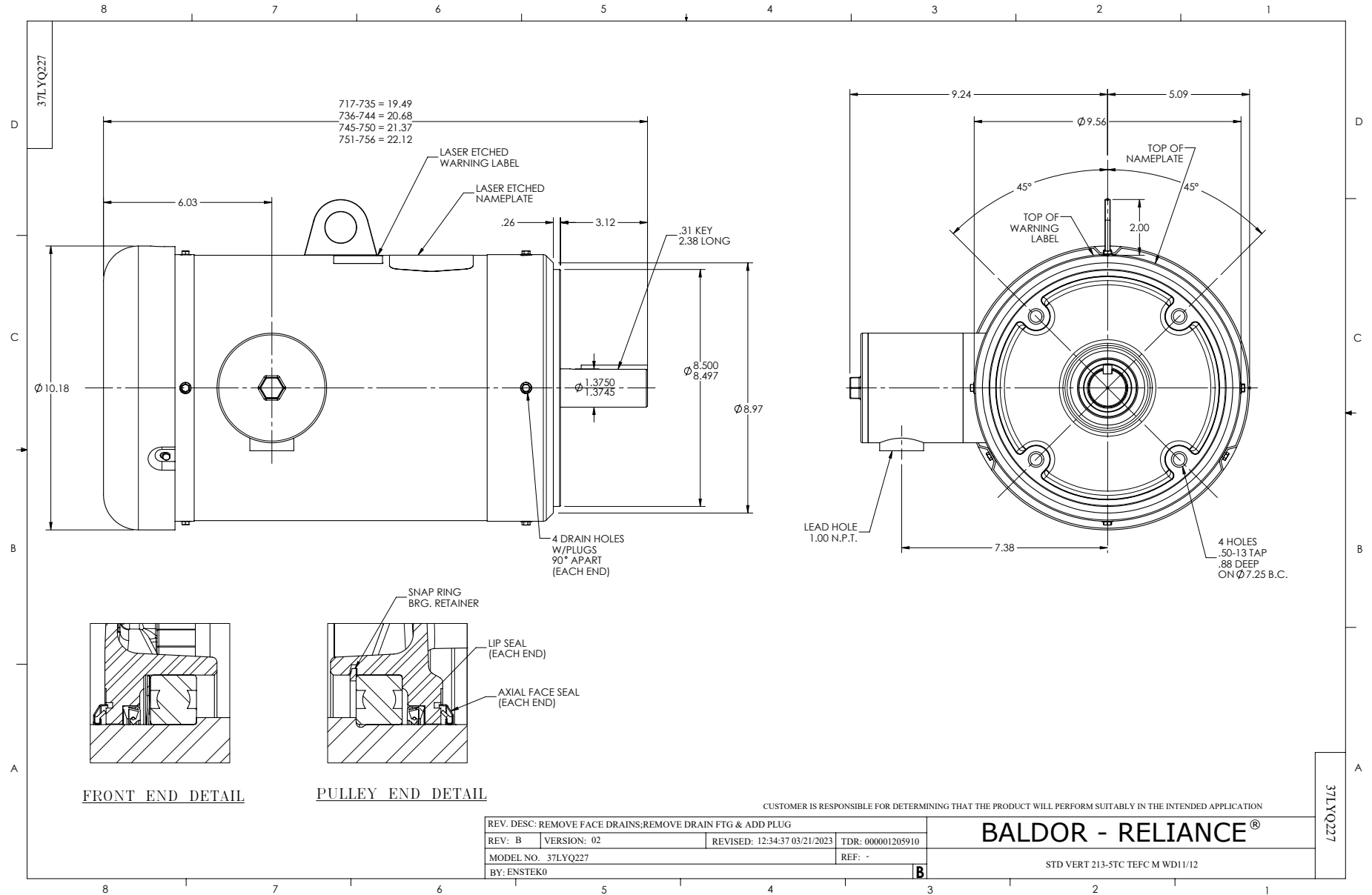

CD0180

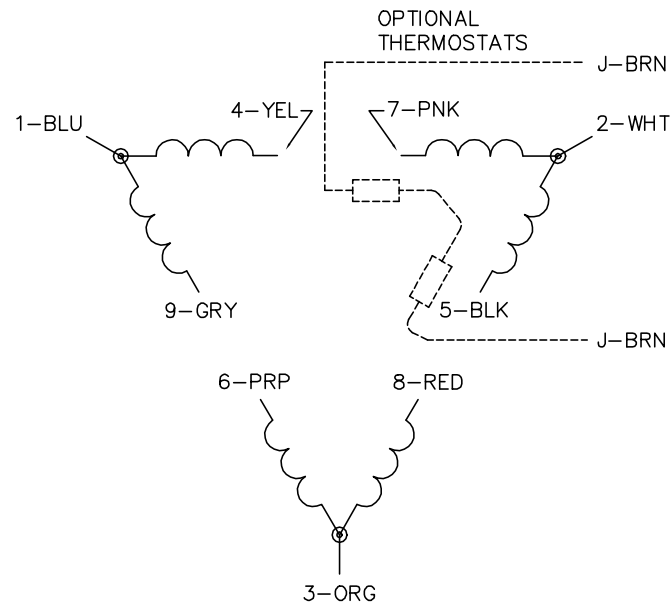

LOW VOLTAGE
(2D)

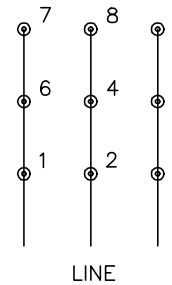

HIGH VOLTAGE
(1D)

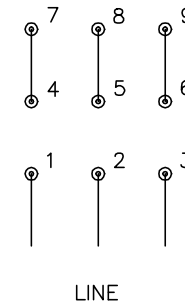

NOTES:

1. INTERCHANGE ANY TWO LINE LEADS TO REVERSE ROTATION.
2. OPTIONAL THERMOSTATS ARE PROVIDED WHEN SPECIFIED.
3. ACTUAL NUMBER OF INTERNAL PARALLEL CIRCUITS MAY BE A MULTIPLE OF THOSE SHOWN ABOVE.
4. LEAD COLORS ARE OPTIONAL. LEADS MUST ALWAYS BE NUMBERED AS SHOWN.

CD0180

REV. DESC: ADD CLASS CONN00000007		
REV. LTR: D	VERSION: 01	TDR: 000001099922
FILE: \AAA\00005\148	REVISED: 10: 25: 29 02/19/2019	BY: ENBRIRO
MTL: -	© □	

BALDOR - RELIANCE®

3PH, DV, 9 LEADS, DELTA CONNECTION

SH 1 of 1