

**BALDOR • RELIANCE**

---

# Customer information packet

## VHECP2334T

20HP, 1770RPM, 3PH, 60HZ, 256HP, 0960M, TEFC, F

Class - None

Division - Not Applicable

## Specifications

Enclosure	TEFC
Frame	256HP
Frame Material	Iron
Frequency	60.00 Hz
Haz Area Class and Group	None
Haz Area Division	Not Applicable
Motor Letter Type	Three Phase
Output @ Frequency	20.000 HP @ 60 HZ
Phase	3
Synchronous Speed @ Frequency	1800 RPM @ 60 HZ
Voltage @ Frequency	460.0 V @ 60 HZ 230.0 V @ 60 HZ
Agency Approvals	CSA CSA EEV UR
Ambient Temperature	40 °C
Auxillary Box	No Auxillary Box
Auxillary Box Lead Termination	None
Base Indicator	No Mounting
Bearing Grease Type	Polyrex EM (-20F +300F)
Blower	None
Current @ Voltage	48.000 A @ 230.0 V 52.000 A @ 208.0 V 24.000 A @ 460.0 V
Design Code	A
Drip Cover	Drip Cover
Duty Rating	CONT
Efficiency @ 100% Load	93.0 %
Electrically Isolated Bearing	Not Electrically Isolated
Feedback Device	NO FEEDBACK
Front Face Code	Standard
Front Shaft Indicator	None

## Part detail

Revision	Q
Type	AC
Mech. spec.	09G604
Base	
Status	PRD/A
Elec. spec.	09WGT459
Layout	09LYG604
Eff. date	02-01-2024
CD Diagram	CD0180
Poles	04
Leads	9#10
Proprietary	False
Created date	11-20-2017

Heater Indicator	No Heater
High Voltage Full Load Amps	24.0 a
Insulation Class	F
Inverter Code	Inverter Ready
KVA Code	J
Lifting Lugs	Vertical Lifting Lugs
Locked Bearing Indicator	Locked Bearing
Motor Lead Exit	Ko Box
Motor Lead Quantity/Wire Size	9 @ 10 AWG
Motor Lead Termination	Flying Leads
Motor Standards	NEMA
Motor Type	0960M
Mounting Arrangement	F1
Number of Poles	4
Overall Length	26.01 IN
Power Factor	83
Product Family	Super-E Chemical Processing
Pulley End Bearing Type	Ball
Pulley Face Code	P-Base
Pulley Shaft Indicator	P-Base Groove & Key
Rodent Screen	None
Service Factor	1.15
Shaft Diameter	1.125 IN
Shaft Extension Location	Pulley End
Shaft Ground Indicator	No Shaft Grounding
Shaft Rotation	Reversible
Shaft Slinger Indicator	Shaft Slinger
Speed	1770 rpm
Speed Code	Single Speed
Starting Method	Direct on line
Thermal Device - Bearing	None
Thermal Device - Winding	None
Vibration Sensor Indicator	No Vibration Sensor
Winding Thermal 1	None

**Winding Thermal 2**

**None**

---

**Nameplate**

<b>NP1260</b>									
<b>CAT.NO.</b>	VHECP2334T								
<b>SPEC.</b>	09G604T459								
<b>HP</b>	20								
<b>VOLTS</b>	230/460								
<b>AMP</b>	48/24								
<b>RPM</b>	1770								
<b>FRAME</b>	256HP	<b>HZ</b>	60	<b>PH</b>	3				
<b>SER.F.</b>	1.15	<b>CODE</b>	J	<b>DES</b>	A	<b>CL</b>	F		
<b>NEMA-NOM-EFF</b>	93	<b>PF</b>	83						
<b>RATING</b>	40C AMB-CONT								
<b>CC</b>	010A								
<b>DE</b>	6311	<b>ODE</b>	6208						
<b>ENCL</b>	TEFC	<b>SN</b>							
	SFA 54.4/27.2								

## Parts list

Part number	Description	Quantity
SA348033	SA 09G604T459	1.000 ea
RA336591	RA 09G604T459	1.000 ea
09FN3001D01SP	EXTERNAL FAN, PLASTIC (COMES W/SCREW FRO	1.000 ea
09CB1002A13P	KOBX W/1.50 NPT LEAD HL,2.38 MTG HL PATT	1.000 ea
09GS1010	GASKET, DWG, LEADWIRE SEPERATOR	1.000 ea
51XW2520A12	.25-20 X .75, TAPTITE II, HEX WSHR SLTD	4.000 ea
HW1001A25	LOCKWASHER 1/4, ZINC PLT .493 OD, .255 I	4.000 ea
HA3400A33	STUD- 3/8-16 X 4.96 HEX	4.000 ea
WD1000B16	T&B CX70TN OR L70P TERMINAL LUG	1.000 ea
10XN2520K12	1/4-20 X.75 GRD 5	1.000 ea
HW1001A25	LOCKWASHER 1/4, ZINC PLT .493 OD, .255 I	1.000 ea
HW1001A38	LOCKWASHER 3/8, ZINC PLT .688 OD, .382 I	4.000 ea
HW4600B44	V-RING SLINGER 1.500 X 1.810 X .28 VITON	1.000 ea
HW5100A08	W3118-035 WVY WSHR (WB)	1.000 ea
10XN2520K28	1/4-20 X 1.75" HX HD SCRWGRADE 5, ZINC P	2.000 ea
10XN3118K56	5/16-18 X 3.50" HEX HD, GRADE 5	4.000 ea
10XN3816K24	3/8-16 X 1.50 HEX HD CAP SCREW, GRADE 5	4.000 ea
HW1001A38	LOCKWASHER 3/8, ZINC PLT .688 OD, .382 I	4.000 ea
HW4600E45	SKF 20596 DBL LIP VITON SEAL 2.063 I.D.	1.000 ea
HW4600B40	V-RING SLINGER 2.000 X 2.680 X .28 VITON	1.000 ea
09FH1000A11P	FAN COVER, MACH P-BASE W/EPOXY PRIMER	1.000 ea
HW1001A38	LOCKWASHER 3/8, ZINC PLT .688 OD, .382 I	4.000 ea
XY3816A12	3/8-16 FINISHED NUT W/SERRATIONS	4.000 ea
HA6387P	EYE BRACKET PRIMED	2.000 ea
10XN3816K20	3/8-16 X 1.25 HEX HD CAP GRADE 5	4.000 ea
HW1001A38	LOCKWASHER 3/8, ZINC PLT .688 OD, .382 I	4.000 ea
XY3816A12	3/8-16 FINISHED NUT W/SERRATIONS	4.000 ea
09FH1500A01P	DRIP COVER, MACH W/EPOXY PRIMER	1.000 ea
10XN2520K30	STD.25X20 THD HEX HD CAP SCREW, GRADE 5	4.000 ea
HW1000A25	1/4 SAE FLAT WASHER (FS)	4.000 ea
12CB1503P	CONDUIT BOX LID, CAST W/EPOXY PRIMER	1.000 ea

12GS1002	GASKET, CONDUIT BOX LID, NEOP	1.000 ea
10XN3118K16	5/16-18 X 1' GRADE #5, STL, ZINC PLATE	2.000 ea
HW1001A31	LOCKWASHER 5/16, ZINC PLT.591 OD, .319 I	2.000 ea
HW2501E18	KEY, 1/4 SQ X 2.000	1.000 ea
MJ5001A27	32220KN GRAY SEALER *MIN BUY 4 QTS=1GAL	0.031 qt
MJ5001A14	DYNAPRO SEALANT, CP MTR VC#2508050 (603	0.023 ea
LB1002N	LABEL,MARINE DUTY (ON ROLLS)	1.000 ea
LB1182	WARNING LABEL FOR MOTORS WITH EYENUTS	2.000 ea
PK6014	STEEL STRAP FOR 309-312 BASELESS MOTORS	4.000 ea
19XW3118A08	.31-18 X .50 HEX WASHER HEAD TAPTITE II	4.000 ea
09EP1100A28LP5	FRONT ENDPLATE, MACH W/BLACK EPOXY PRIM	1.000 ea
HW4500A05	1669B ALEM/UNIV860 GR FTG X	1.000 ea
HW4500A17	317400 ALEMITE GREASE RELIEF	1.000 ea
HA4051A00	PLASTIC CAP FOR GREASE FITTING	1.000 ea
MJ1000A02	GREASE, POLYREX EM EXXON	0.080 lb
09EP1505A11P	PU ENDPLATE ENCL 213 BRG 309 254-256LP,	1.000 ea
HW4500A17	317400 ALEMITE GREASE RELIEF	1.000 ea
HW4500A03	GREASE FITTING, .125 NPT 1610(ALEMITE) 8	1.000 ea
HA4051A00	PLASTIC CAP FOR GREASE FITTING	1.000 ea
HW2500A25	WOODRUFF KEY USA #1008 #BLOW CARBON STEE	1.000 ea
MG1025N19	WILKOFAS, 778.50, RELIANCE BLUE-GREEN 8	0.050 ga
85XU0407S04	4X1/4 U DRIVE PIN STAINLESS	2.000 ea
LB1624	COMBINED WARNING LABEL, ISO/ANSI PICTOGR	1.000 ea
LC0181	CONNECTION LABEL	1.000 ea
NP1260	SS CP SUPER-E, CURUS-E, NEMA PREM, CC	1.000 ea
40PA1014	PACKAGING GROUP, 09 NO BASE	1.000 ea
MN416A01	TAG-INSTAL-MAINT no wire (2500bx)4/22	1.000 ea
LD7020E09	LEAD SET, 10AWG, 9 LEAD, 20" LONG LEADS	1.000 ea

**AC Induction Motor Performance Data**

Record # 67948

Typical performance - not guaranteed values

Winding: 09WGT459-R001		Type: 0960M	Enclosure: TEFC		
<b>Nameplate Data</b>			<b>460 V, 60 Hz: High Voltage Connection</b>		
Rated Output (HP)	20	Full Load Torque	59.27 LB-FT		
Volts	230/460	Start Configuration	direct on line		
Full Load Amps	48/24	Breakdown Torque	232 LB-FT		
R.P.M.	1770	Pull-up Torque	126 LB-FT		
Hz	60 Phase	3	Locked-rotor Torque	141 LB-FT	
NEMA Design Code	A	KVA Code	J	Starting Current	198 A
Service Factor (S.F.)	1.15		No-load Current	10.4 A	
NEMA Nom. Eff.	93	Power Factor	83	Line-line Res. @ 25°C	0.33814 Ω
Rating - Duty	40C AMB-CONT		Temp. Rise @ Rated Load	58°C	
S.F. Amps			Temp. Rise @ S.F. Load	70°C	
			Locked-rotor Power Factor	26.9	

**Load Characteristics 460 V, 60 Hz, 20 HP**

% of Rated Load	25	50	75	100	125	150	S.F.
Power Factor	45	67	78	83	86	87	85
Efficiency	89.2	93	93.7	93.6	93.1	92.4	93.3
Speed	1793.2	1786.4	1779.1	1771.9	1763.7	1755.3	1767
Line amperes	11.8	15	19.2	24	29.3	34.9	27.2



ABB Motors and Mechanical Inc.

WINDING # 09WGT459

Typical performance - not guaranteed values.

20 HP 3 PH 60 HZ 1770 RPM 460 V 0960M

TORQUES (LB-FT): PO=232 PU=126 LR=141 LRA=198

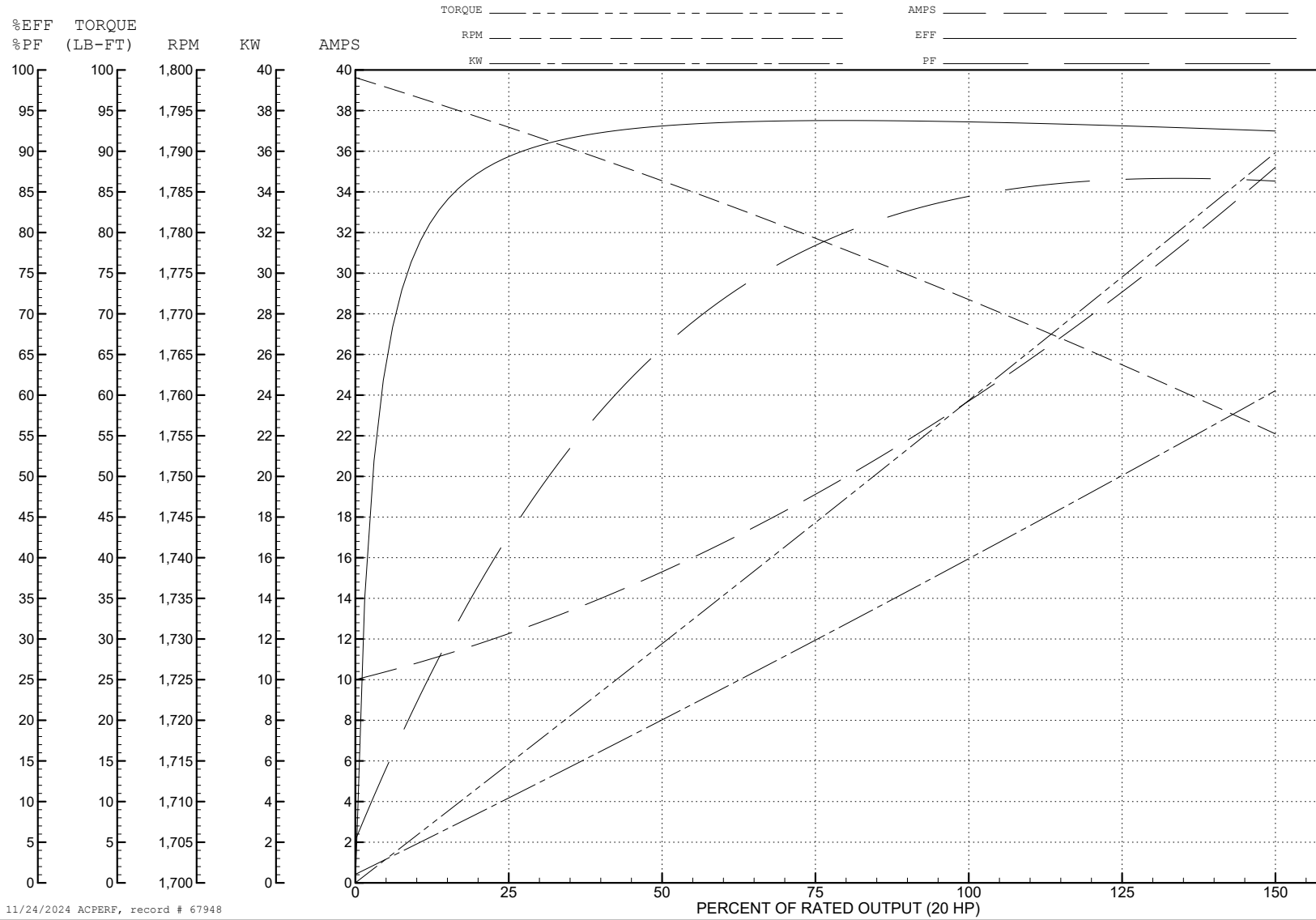

11/24/2024 ACPERF, record # 67948

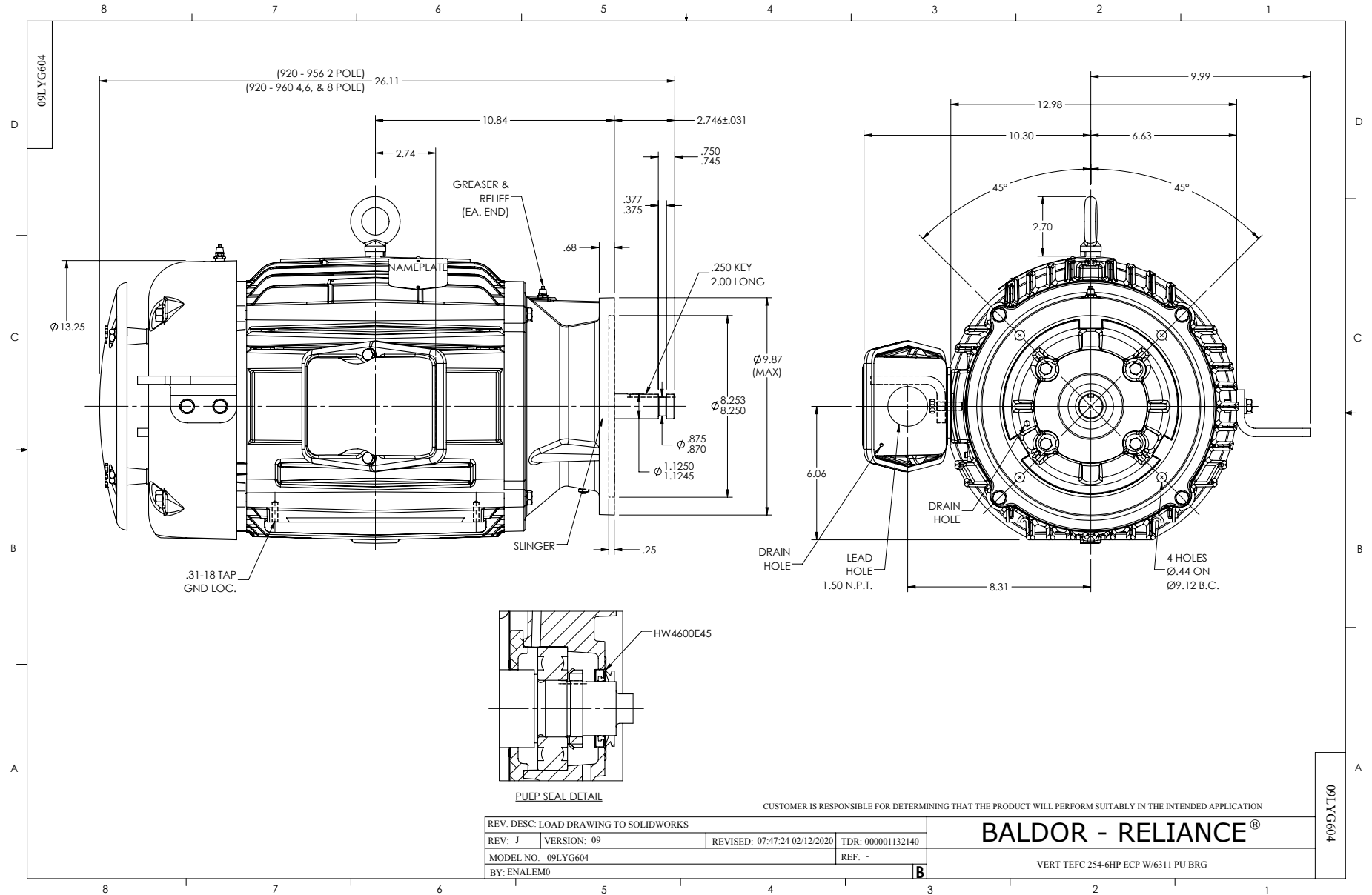

CD0180

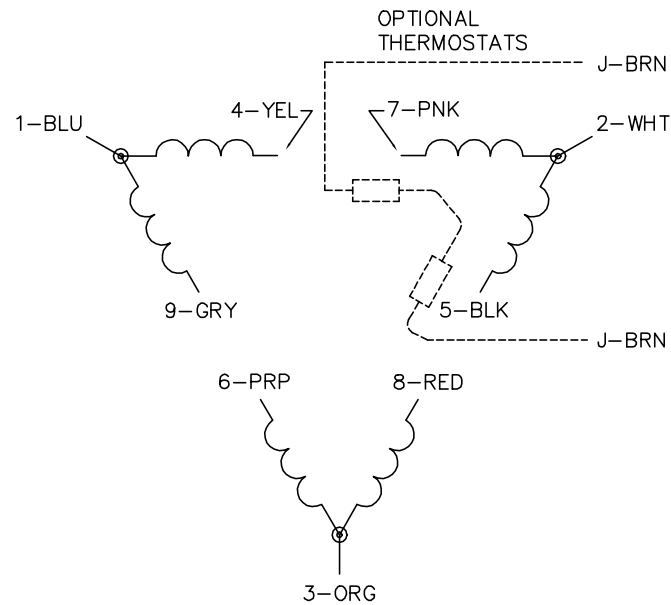

LOW VOLTAGE  
(2D)

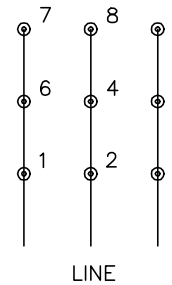

HIGH VOLTAGE  
(1D)

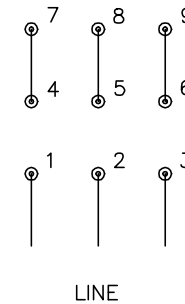

NOTES:

1. INTERCHANGE ANY TWO LINE LEADS TO REVERSE ROTATION.
2. OPTIONAL THERMOSTATS ARE PROVIDED WHEN SPECIFIED.
3. ACTUAL NUMBER OF INTERNAL PARALLEL CIRCUITS MAY BE A MULTIPLE OF THOSE SHOWN ABOVE.
4. LEAD COLORS ARE OPTIONAL. LEADS MUST ALWAYS BE NUMBERED AS SHOWN.

CD0180

REV. DESC: ADD CLASS CONN00000007		
REV. LTR: D	VERSION: 01	TDR: 000001099922
FILE: \AAA\00005\148	REVISED: 10: 25: 29 02/19/2019	BY: ENBRIRO
MTL: -	© □	

**BALDOR - RELIANCE®**

3PH, DV, 9 LEADS, DELTA CONNECTION

SH 1 of 1