

BALDOR • RELIANCE

Customer information packet

VHECP4108T

30HP, 3520RPM, 3PH, 60HZ, 286HP, 0950M, TEFC, F

Class - None

Division - Not Applicable

Specifications

Enclosure	TEFC
Frame	286HP
Frame Material	Iron
Frequency	60.00 Hz
Haz Area Class and Group	None
Haz Area Division	Not Applicable
Motor Letter Type	Three Phase
Output @ Frequency	30.000 HP @ 60 HZ
Phase	3
Synchronous Speed @ Frequency	3600 RPM @ 60 HZ
Voltage @ Frequency	460.0 V @ 60 HZ 230.0 V @ 60 HZ
Agency Approvals	CSA CSA EEV UR
Ambient Temperature	40 °C
Auxillary Box	No Auxillary Box
Auxillary Box Lead Termination	None
Base Indicator	No Mounting
Bearing Grease Type	Polyrex EM (-20F +300F)
Blower	None
Current @ Voltage	68.000 A @ 230.0 V 74.000 A @ 208.0 V 34.000 A @ 460.0 V
Design Code	A
Drip Cover	Drip Cover
Duty Rating	CONT
Efficiency @ 100% Load	91.7 %
Electrically Isolated Bearing	Not Electrically Isolated
Feedback Device	NO FEEDBACK
Front Face Code	Standard
Front Shaft Indicator	None

Part detail

Revision	K
Type	AC
Mech. spec.	09G614
Base	
Status	PRD/A
Elec. spec.	09WGT474
Layout	09LYG614
Eff. date	11-14-2023
CD Diagram	CD0180
Poles	02
Leads	9#10
Proprietary	False
Created date	11-09-2017

Heater Indicator	No Heater
High Voltage Full Load Amps	34.0 a
Insulation Class	F
Inverter Code	Inverter Ready
KVA Code	J
Lifting Lugs	Vertical Lifting Lugs
Locked Bearing Indicator	Locked Bearing
Motor Lead Exit	Ko Box
Motor Lead Quantity/Wire Size	9 @ 10 AWG
Motor Lead Termination	Flying Leads
Motor Standards	NEMA
Motor Type	0950M
Mounting Arrangement	F1
Number of Poles	2
Overall Length	25.72 IN
Power Factor	89
Product Family	Super-E Chemical Processing
Pulley End Bearing Type	Ball
Pulley Face Code	P-Base
Pulley Shaft Indicator	P-Base Groove & Key
Rodent Screen	None
Service Factor	1.15
Shaft Diameter	1.125 IN
Shaft Extension Location	Pulley End
Shaft Ground Indicator	No Shaft Grounding
Shaft Rotation	Reversible
Shaft Slinger Indicator	Shaft Slinger
Speed	3520 rpm
Speed Code	Single Speed
Starting Method	Direct on line
Thermal Device - Bearing	None
Thermal Device - Winding	None
Vibration Sensor Indicator	No Vibration Sensor
Winding Thermal 1	None

Winding Thermal 2

None

Nameplate

NP1260									
CAT.NO.	VHECP4108T								
SPEC.	09G614T474								
HP	30								
VOLTS	230/460								
AMP	68/34								
RPM	3520								
FRAME	286HP	HZ	60	PH	3				
SER.F.	1.15	CODE	J	DES	A	CL	F		
NEMA-NOM-EFF	91.7	PF	89						
RATING	40C AMB-CONT								
CC	010A								
DE	6311	ODE	6208						
ENCL	TEFC	SN							

Parts list

Part number	Description	Quantity
SA347593	SA 09G614T474	1.000 ea
RA336150	RA 09G614T474	1.000 ea
09FN3001D01SP	EXTERNAL FAN, PLASTIC (COMES W/SCREW FRO	1.000 ea
10CB1000A16P	KOBX, MACH 2.00 NPT W/#26 DRAIN W/PRIMER	1.000 ea
09GS1010	GASKET, DWG, LEADWIRE SEPERATOR	1.000 ea
10XN3118K16	5/16-18 X 1' GRADE #5, STL, ZINC PLATE	4.000 ea
HW1001A31	LOCKWASHER 5/16, ZINC PLT .591 OD, .319 I	4.000 ea
WD1000B16	T&B CX70TN OR L70P TERMINAL LUG	1.000 ea
10XN2520K06	1/4-20 X 3/8" HX HD SCREWGRADE 5, ZINC P	1.000 ea
HW1001A25	LOCKWASHER 1/4, ZINC PLT .493 OD, .255 I	1.000 ea
HA4051A00	PLASTIC CAP FOR GREASE FITTING	1.000 ea
HA3400A33	STUD- 3/8-16 X 4.96 HEX	4.000 ea
HW1001A38	LOCKWASHER 3/8, ZINC PLT .688 OD, .382 I	4.000 ea
HW4600B44	V-RING SLINGER 1.500 X 1.810 X .28 VITON	1.000 ea
HW5100A08	W3118-035 WVY WSHR (WB)	1.000 ea
10XN2520K28	1/4-20 X 1.75" HX HD SCRWGRADE 5, ZINC P	2.000 ea
10XN3118K56	5/16-18 X 3.50" HEX HD, GRADE 5	4.000 ea
09EP1505A11P	PU ENDPLATE ENCL 213 BRG 309 254-256LP,	1.000 ea
HA4051A00	PLASTIC CAP FOR GREASE FITTING	1.000 ea
10XN3816K24	3/8-16 X 1.50 HEX HD CAP SCREW, GRADE 5	4.000 ea
HW1001A38	LOCKWASHER 3/8, ZINC PLT .688 OD, .382 I	4.000 ea
HW4600E45	SKF 20596 DBL LIP VITON SEAL 2.063 I.D.	1.000 ea
HW4600B40	V-RING SLINGER 2.000 X 2.680 X .28 VITON	1.000 ea
09FH1000A11P	FAN COVER, MACH P-BASE W/EPOXY PRIMER	1.000 ea
HW1001A38	LOCKWASHER 3/8, ZINC PLT .688 OD, .382 I	4.000 ea
XY3816A12	3/8-16 FINISHED NUT W/SERRATIONS	4.000 ea
HA6387P	EYE BRACKET PRIMED	2.000 ea
10XN3816K20	3/8-16 X 1.25 HEX HD CAP GRADE 5	4.000 ea
HW1001A38	LOCKWASHER 3/8, ZINC PLT .688 OD, .382 I	4.000 ea
XY3816A12	3/8-16 FINISHED NUT W/SERRATIONS	4.000 ea
09FH1500A01P	DRIP COVER, MACH W/EPOXY PRIMER	1.000 ea

10XN2520K30	STD.25X20 THD HEX HD CAP SCREW, GRADE 5	4.000 ea
HW1000A25	1/4 SAE FLAT WASHER (FS)	4.000 ea
HW1001A25	LOCKWASHER 1/4, ZINC PLT .493 OD, .255 I	4.000 ea
10CB1503A01P	CONDUIT BOX LIPPED LID, MACH W/EPXY PRMR	1.000 ea
14GS1003	GASKET CONDUIT BOX LID, NEOP	1.000 ea
10XN2520K16	1/4-20 X 1" HX HD SCRW GRADE 5, ZINC P	2.000 ea
HW1001A25	LOCKWASHER 1/4, ZINC PLT .493 OD, .255 I	2.000 ea
HW2501E11	KEY, 1/4 SQ X 1.125	1.000 ea
MJ5001A27	32220KN GRAY SEALER *MIN BUY 4 QTS=1GAL	0.031 qt
MJ5001A14	DYNAPRO SEALANT, CP MTR VC#2508050 (603	0.023 ea
LB1002N	LABEL,MARINE DUTY (ON ROLLS)	1.000 ea
LB1182	WARNING LABEL FOR MOTORS WITH EYENUTS	2.000 ea
10XN3816K10	BOLT, 3/8-16 X 5/8 HHCS YZ	3.000 ea
09EP1100A28LP5	FRONT ENDPLATE, MACH W/BLACK EPOXY PRIM	1.000 ea
HW4500A05	1669B ALEM/UNIV860 GR FTG X	1.000 ea
HW4500A17	317400 ALEMITE GREASE RELIEF	1.000 ea
MJ1000A02	GREASE, POLYREX EM EXXON	0.080 lb
HW4500A03	GREASE FITTING, .125 NPT 1610(ALEMITE) 8	1.000 ea
HW4500A17	317400 ALEMITE GREASE RELIEF	1.000 ea
HW2500A25	WOODRUFF KEY USA #1008 #BLOW CARBON STEE	1.000 ea
MG1025N19	WILKOFASST, 778.50, RELIANCE BLUE-GREEN 8	0.050 ga
85XU0407S04	4X1/4 U DRIVE PIN STAINLESS	2.000 ea
LB1624	COMBINED WARNING LABEL, ISO/ANSI PICTOGR	1.000 ea
LC0181	CONNECTION LABEL	1.000 ea
NP1260	SS CP SUPER-E, CURUS-E, NEMA PREM, CC	1.000 ea
40PA1019	WOODBASE 310 RISER SIDE LUG WITH PK1023	1.000 ea
MN416A01	TAG-INSTAL-MAINT no wire (2500bx)4/22	1.000 ea

AC Induction Motor Performance Data

Record # 67631

Typical performance - not guaranteed values

Winding: 09WGT474-R001		Type: 0950M		Enclosure: TEFC	
Nameplate Data			460 V, 60 Hz: High Voltage Connection		
Rated Output (HP)	30	Full Load Torque	44.65 LB-FT		
Volts	230/460	Start Configuration	direct on line		
Full Load Amps	68/34	Breakdown Torque	173 LB-FT		
R.P.M.	3520	Pull-up Torque	87.6 LB-FT		
Hz	60 Phase	3	Locked-rotor Torque	104 LB-FT	
NEMA Design Code	A KVA Code	J	Starting Current	283 A	
Service Factor (S.F.)		1.15	No-load Current	10.9 A	
NEMA Nom. Eff.	91.7 Power Factor	90	Line-line Res. @ 25°C	0.2527 Ω	
Rating - Duty		40C AMB-CONT	Temp. Rise @ Rated Load	79°C	
S.F. Amps			Temp. Rise @ S.F. Load	97°C	
			Locked-rotor Power Factor	28	

Load Characteristics 460 V, 60 Hz, 30 HP

% of Rated Load	25	50	75	100	125	150	S.F.
Power Factor	58	78	86	89	90	91	90
Efficiency	87.7	91.8	92.4	92.1	91.3	90.2	91.6
Speed	3580.7	3562.2	3542.3	3521	3497.7	3471	3507
Line amperes	13.7	19.4	26.4	34.2	42.4	51.3	39.1

ABB Motors and Mechanical Inc.

WINDING # 09WGT474

30 HP 3 PH 60 HZ 3520 RPM 460 V 0950M

Typical performance - not guaranteed values.

TORQUES (LB-FT): PO=173 PU=87.6 LR=104 LRA=283

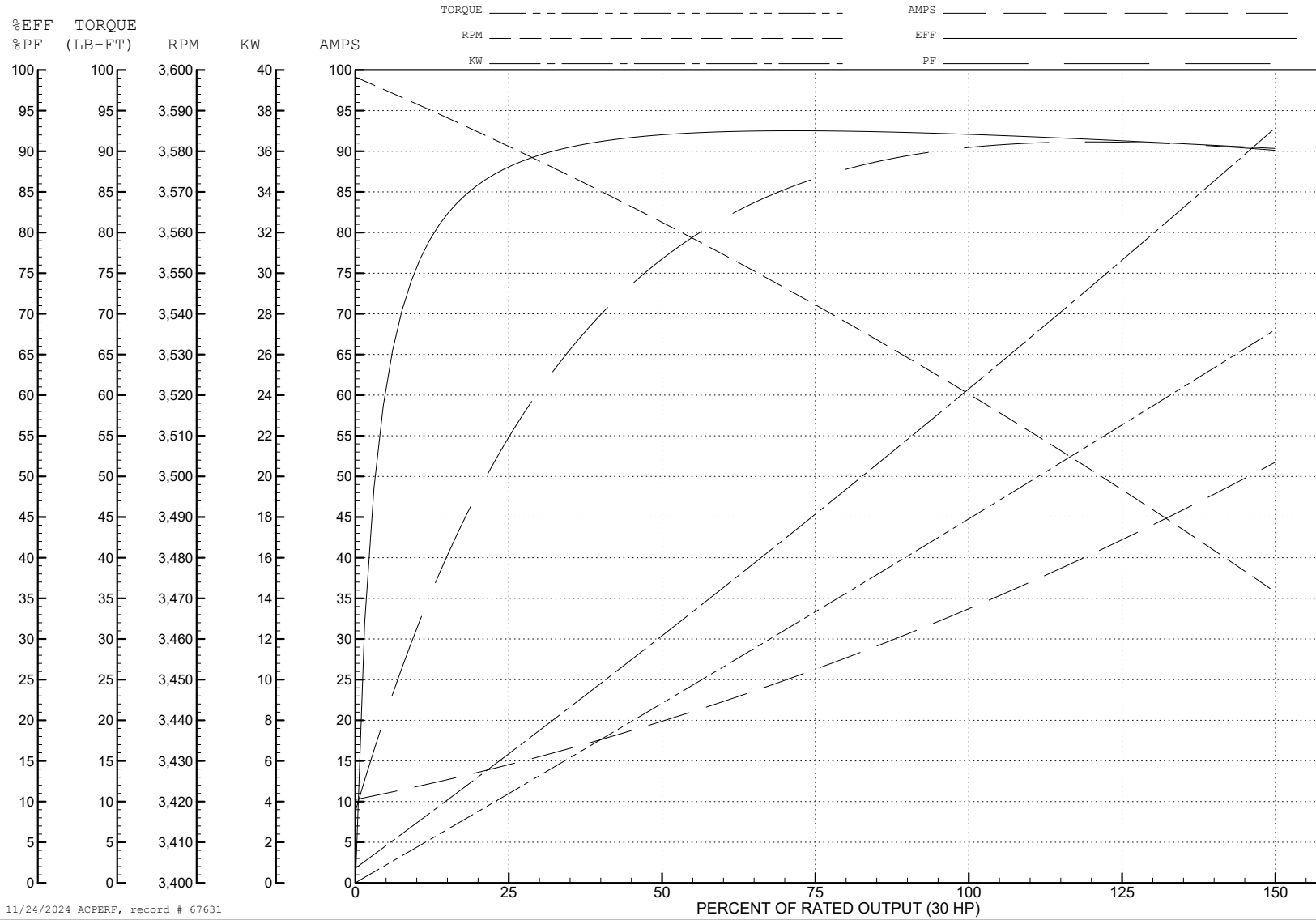

11/24/2024 ACPERF, record # 67631

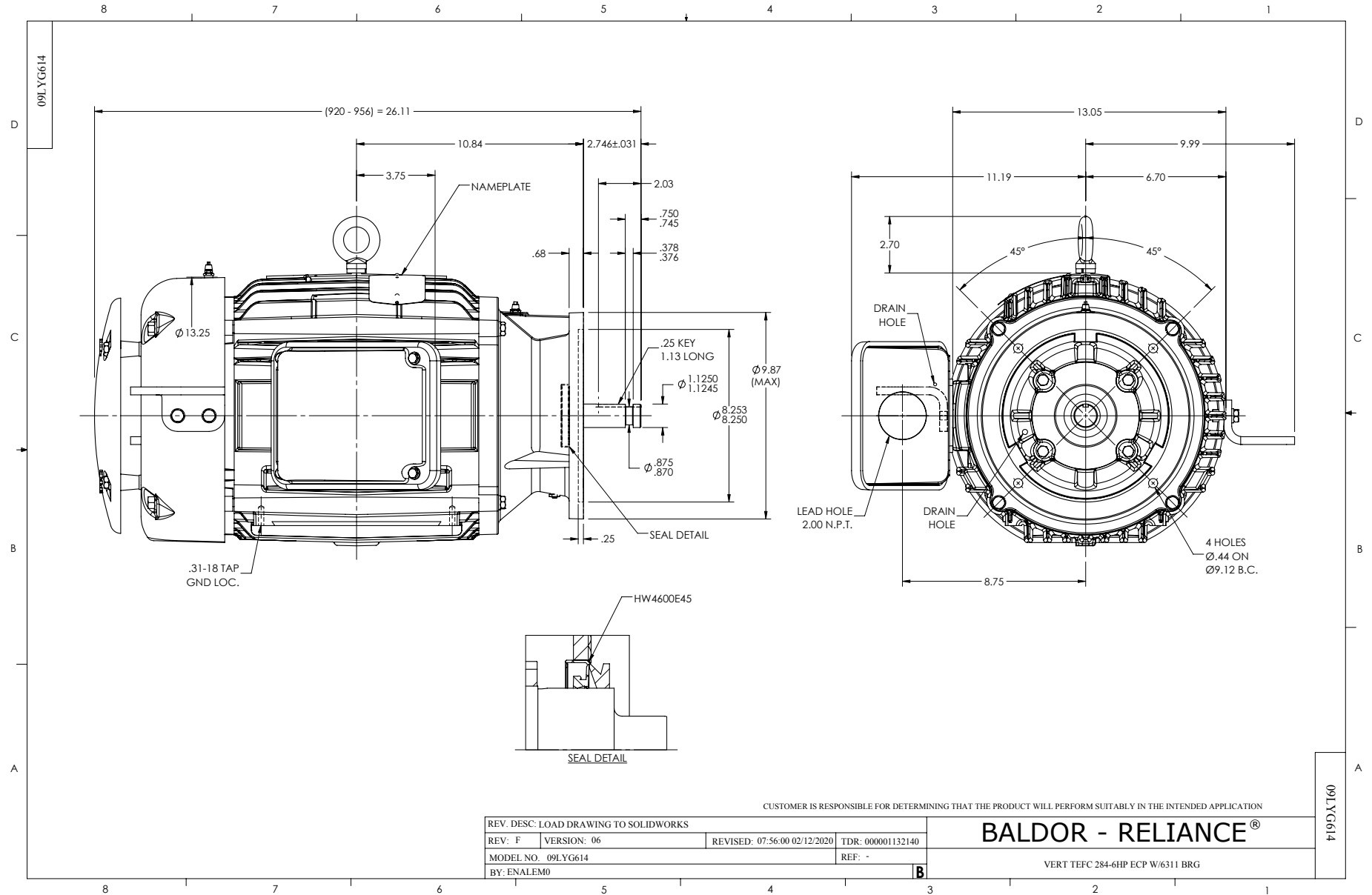

CD0180



LOW VOLTAGE
(2D)



HIGH VOLTAGE
(1D)



NOTES:

1. INTERCHANGE ANY TWO LINE LEADS TO REVERSE ROTATION.
2. OPTIONAL THERMOSTATS ARE PROVIDED WHEN SPECIFIED.
3. ACTUAL NUMBER OF INTERNAL PARALLEL CIRCUITS MAY BE A MULTIPLE OF THOSE SHOWN ABOVE.
4. LEAD COLORS ARE OPTIONAL. LEADS MUST ALWAYS BE NUMBERED AS SHOWN.

CD0180

REV. DESC: ADD CLASS CONN00000007		
REV. LTR: D	VERSION: 01	TDR: 000001099922
FILE: \AAA\00005\148	REVISED: 10: 25: 29 02/19/2019	BY: ENBRIRO
MTL: -	© □	

BALDOR - RELIANCE®

3PH, DV, 9 LEADS, DELTA CONNECTION

SH 1 of 1