

BALDOR • RELIANCE

Customer information packet

VHEM2534T

30HP, 3525RPM, 3PH, 60HZ, 284HP, 1048M, OPEN, F

Class - None

Division - Not Applicable

Copyright © All product information within this document is subject to ABB Motors and Mechanical Inc. copyright © protection, unless otherwise noted.

11/24/2024 12:44:44 PM

Specifications

Enclosure	OPEN
Frame	284HP
Frame Material	Iron
Frequency	60.00 Hz
Haz Area Class and Group	None
Haz Area Division	Not Applicable
Motor Letter Type	Three Phase
Output @ Frequency	30.000 HP @ 60 HZ
Phase	3
Synchronous Speed @ Frequency	3600 RPM @ 60 HZ
Voltage @ Frequency	230.0 V @ 60 HZ 460.0 V @ 60 HZ
Agency Approvals	UR CSA CSA EEV
Ambient Temperature	40 °C
Auxillary Box	No Auxillary Box
Auxillary Box Lead Termination	None
Base Indicator	No Mounting
Bearing Grease Type	Polyrex EM (-20F +300F)
Blower	None
Current @ Voltage	68.000 A @ 230.0 V 34.000 A @ 460.0 V
Design Code	B
Drip Cover	Drip Cover
Duty Rating	CONT
Efficiency @ 100% Load	91.7 %
Electrically Isolated Bearing	Not Electrically Isolated
Feedback Device	NO FEEDBACK
Front Face Code	Drip Cover Mounting
Front Shaft Indicator	None
Heater Indicator	No Heater

Part detail

Revision	C
Type	AC
Mech. spec.	10F886
Base	
Status	NLA/A
Elec. spec.	10WGZ682
Layout	10LYF886
Eff. date	02-21-2022
CD Diagram	CD0180
Poles	02
Leads	9#10
Proprietary	False
Created date	08-31-2017

High Voltage Full Load Amps	34.0 a
Insulation Class	F
Inverter Code	Inverter Ready
KVA Code	G
Lifting Lugs	Standard Lifting Lugs
Locked Bearing Indicator	Locked Bearing
Motor Lead Exit	Ko Box
Motor Lead Quantity/Wire Size	9 @ 10 AWG
Motor Lead Termination	Flying Leads
Motor Standards	NEMA
Motor Type	1048M
Mounting Arrangement	F1
Number of Poles	2
Overall Length	29.93 IN
Power Factor	90
Product Family	General Purpose
Pulley End Bearing Type	Ball
Pulley Face Code	P-Base
Pulley Shaft Indicator	P-Base Groove & Key
Rodent Screen	None
Service Factor	1.15
Shaft Diameter	1.125 IN
Shaft Extension Location	Pulley End
Shaft Ground Indicator	No Shaft Grounding
Shaft Rotation	Reversible
Shaft Slinger Indicator	Shaft Slinger
Speed	3525 rpm
Speed Code	Single Speed
Starting Method	Direct on line
Thermal Device - Bearing	NONE (OLD)
Thermal Device - Winding	None
Vibration Sensor Indicator	No Vibration Sensor
Winding Thermal 1	None
Winding Thermal 2	None

Nameplate

NP2138L

CAT.NO.	VHEM2534T	P/N		ENCLOSURE	OPEN		
SPEC.	10F886Z682G1	CC	010A	FRAME	284HP	S/N	
HP	30	CLASS	F	HZ	60		
RPM	3525	PH	3	DES	B		
VOLT	230/460	KVA-CODE	G	ODE BRG	6309	DE BRG	6312
AMP	68/34						
RATING	40C AMB-CONT	GREASE	POLYREX EM				
NEMA-NOM-EFF	91.7	PF	90	SER.F.	1.15		
HTR-VOLTS		HTR-AMPS					

Parts list

Part number	Description	Quantity
SA344153	SA 10F886Z682G1	1.000 ea
RA332629	RA 10F886Z682G1	1.000 ea
10CB3003A04	KO BOX, MACH W/2.00 NPT LD HL & #26 DRAI	1.000 ea
09GS1000	GASKET-CONDUIT BOX, 1/16 THICK LEXIDE	1.000 ea
10XN3118K16	5/16-18 X 1' GRADE #5, STL, ZINC PLATE	4.000 ea
HW1001A31	LOCKWASHER 5/16, ZINC PLT.591 OD, .319 I	4.000 ea
WD1000B16	T&B CX70TN OR L70P TERMINAL LUG	1.000 ea
51XF2520A08	SCREW, HEX SER SLT HD, ZN 1/4-20 X .50 L	1.000 ea
10EP1201A01	FREP, MACH W/309 BRG	1.000 ea
10AD2002	AIR DEFLECTOR, 310 OPEN P-BASE	1.000 ea
12XN1032A08	10-32X1/2 HEX HD SLTD	3.000 ea
HW1001A10	WASHER, #10 SPLT LK, ZN X	3.000 ea
10XN3816K52	3/8-16 X 3-1/4 HEX HEAD CAP SCREW GRD 5	4.000 ea
HW1001A38	LOCKWASHER 3/8, ZINC PLT .688 OD, .382 I	4.000 ea
HW5100A11	W3917-042 WVY WSHR (WB)	1.000 ea
10XN3118K80	.31-18 X 5.0 HEX HD CAP SCREW, GRADE 5	4.000 ea
HW1001A31	LOCKWASHER 5/16, ZINC PLT.591 OD, .319 I	4.000 ea
10EP1507A02	ENDPLATE, MACH W/312 BRG W/SLINGER RECES	1.000 ea
10XN3816K44	3/8-16 X 2.75 HEX HD CAP SCREW, GRADE 5	4.000 ea
HW1001A38	LOCKWASHER 3/8, ZINC PLT .688 OD, .382 I	4.000 ea
HW4600B41	V-RING SLINGER 2.125 X 2.880 X 0.280	1.000 ea
10FH1500A01	DRIP COVER, MACH	1.000 ea
HW3201A12	.50-13 EYEBOLT W/2.25 SHANK	2.000 ea
HW1001A50	LOCKWASHER 1/2, ZINC PLT,.879 OD, .509 I	2.000 ea
HW1000A50	1/2 SAE FLAT WASHERS	2.000 ea
10CB3501	CONDUIT BOX LID FOR 10CB3003, 10CB3004 &	1.000 ea
14GS1001	GASKET, CONDUIT BOX LID 314 FRAME	1.000 ea
10XN2520K16	1/4-20 X 1" HX HD SCRW GRADE 5, ZINC P	4.000 ea
HW1001A25	LOCKWASHER 1/4, ZINC PLT .493 OD, .255 I	4.000 ea
HW2501E11	KEY, 1/4 SQ X 1.125	1.000 ea
LB1182	WARNING LABEL FOR MOTORS WITH EYENUTS	2.000 ea

HW4500A03	GREASE FITTING, .125 NPT 1610(ALEMITE) 8	1.000 ea
HW4500A17	317400 ALEMITE GREASE RELIEF	1.000 ea
HA4051A00	PLASTIC CAP FOR GREASE FITTING	1.000 ea
MJ1000A02	GREASE, POLYREX EM EXXON	0.130 lb
HW4500A03	GREASE FITTING, .125 NPT 1610(ALEMITE) 8	1.000 ea
HW4500A17	317400 ALEMITE GREASE RELIEF	1.000 ea
HA4051A00	PLASTIC CAP FOR GREASE FITTING	1.000 ea
MG1025G05	WILKOFAST, 789.227, MED. GRAY CHAR. MET.	0.200 ga
85XU0407S04	4X1/4 U DRIVE PIN STAINLESS	4.000 ea
LB1624	WARNING LABEL	1.000 ea
LC0181	CONNECTION LABEL	1.000 ea
NP2138L	ALUM SUPER-E UL PREM CC (300	1.000 ea
12PA1030	PACKAGING GROUP PRINT PK1024A07	1.000 ea
PK6562A07	2X4 X 11 SPACER	2.000 ea
MN416A01	TAG-INSTAL-MAINT no wire (2500bx)4/22	1.000 ea

AC Induction Motor Performance Data

Record # 66627

Typical performance - not guaranteed values

Winding: 10WGZ682-R001		Type: 1048M		Enclosure: OPEN	
Nameplate Data			460 V, 60 Hz: High Voltage Connection		
Rated Output (HP)	30	Full Load Torque	44.8 LB-FT		
Volts	230/460	Start Configuration	direct on line		
Full Load Amps	68/34	Breakdown Torque	135 LB-FT		
R.P.M.	3520	Pull-up Torque	47 LB-FT		
Hz	60 Phase	3	Locked-rotor Torque	65.2 LB-FT	
NEMA Design Code	B KVA Code	G	Starting Current	212 A	
Service Factor (S.F.)		1.15	No-load Current	8.74 A	
NEMA Nom. Eff.	91.7 Power Factor	90	Line-line Res. @ 25°C	0.24052 Ω	
Rating - Duty		40C AMB-CONT	Temp. Rise @ Rated Load	69°C	
S.F. Amps			Temp. Rise @ S.F. Load	85°C	
			Locked-rotor Power Factor	23.2	

Load Characteristics 460 V, 60 Hz, 30 HP

% of Rated Load	25	50	75	100	125	150	S.F.
Power Factor	67	83	88	90	90	90	90
Efficiency	87	91.3	92	91.7	90.9	89.7	91.2
Speed	3583	3565.7	3547.3	3526.7	3504.4	3479.1	3513
Line amperes	12.4	18.7	26.1	34.1	43.1	52.5	39.5

ABB Motors and Mechanical Inc.

WINDING # 10WGZ682

30 HP 3 PH 60 HZ 3520 RPM 460 V 1048M

Typical performance - not guaranteed values.

TORQUES (LB-FT): PO=135 PU=47 LR=65.2 LRA=212

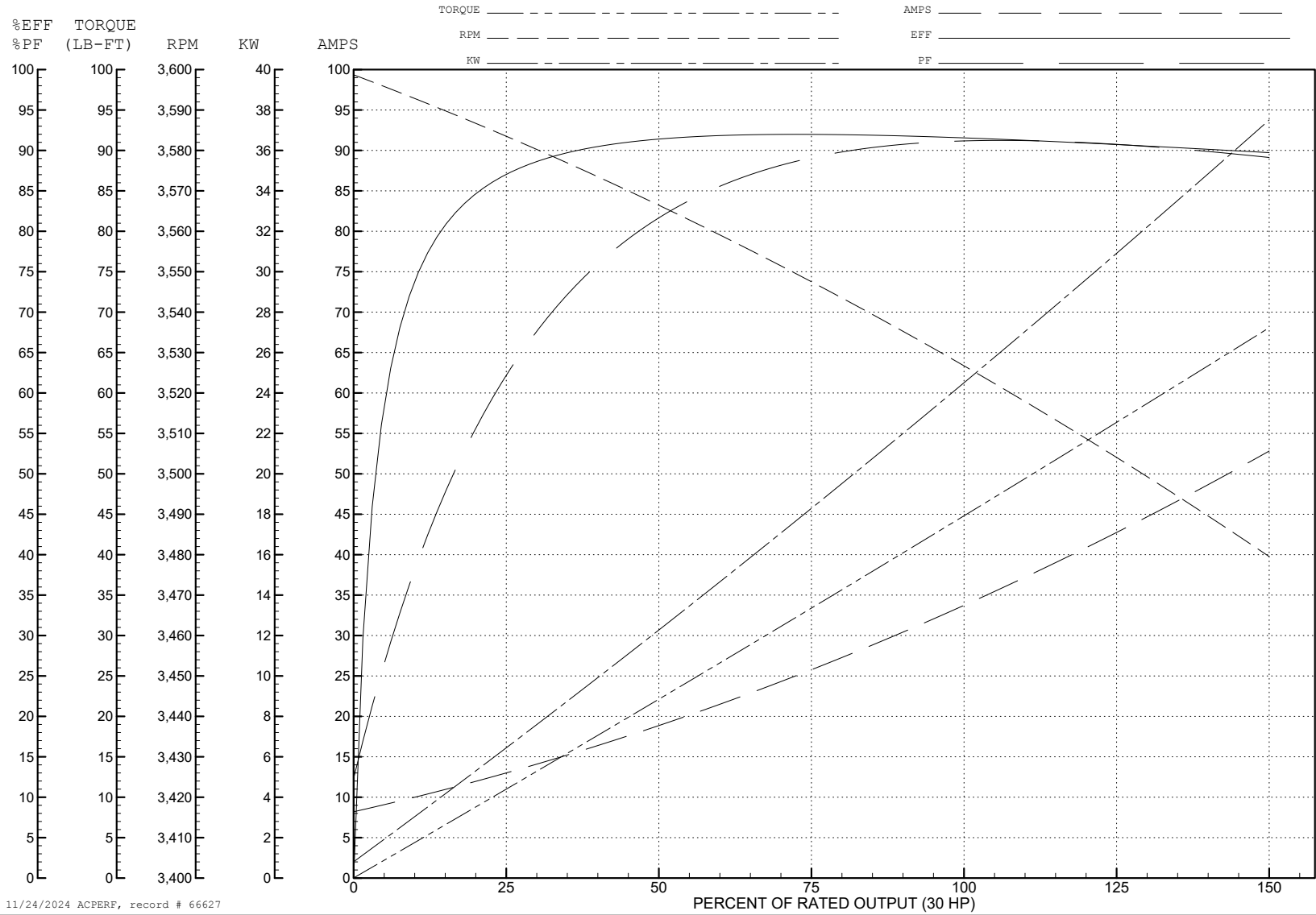

11/24/2024 ACPERF, record # 66627

10LYF886

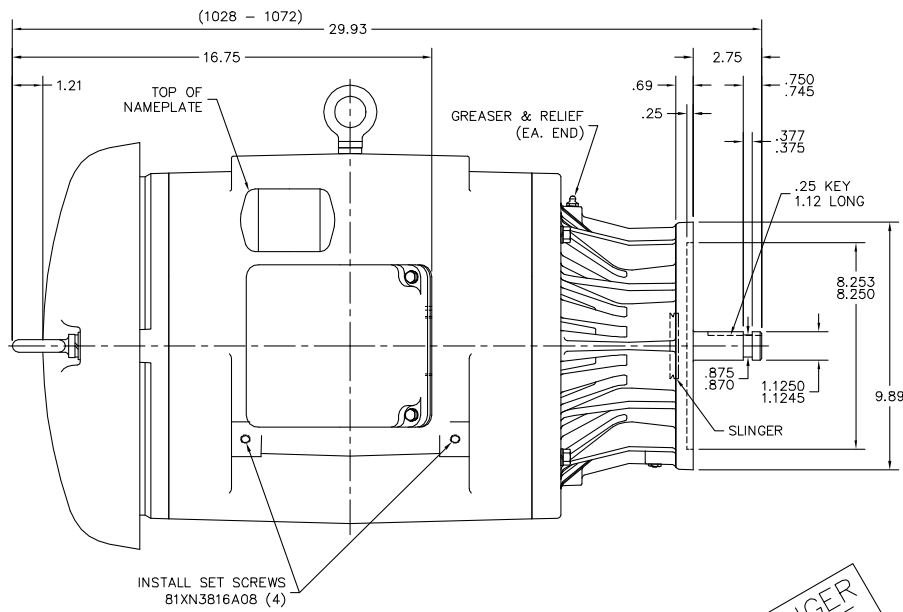

NO LONGER AVAILABLE

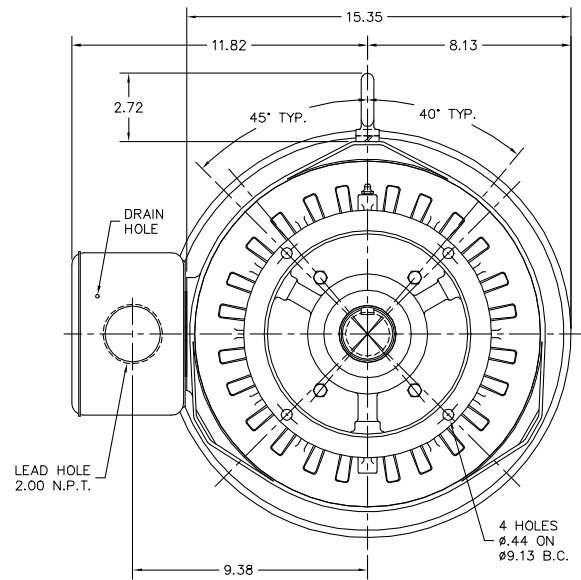

10LYF886

CUSTOMER IS RESPONSIBLE FOR DETERMINING THAT THE PRODUCT WILL PERFORM SUITABLY IN THE INTENDED APPLICATION.

REV. DESC: NLA, PRODUCT LIFECYCLE		
REV. LTR: D	VERSION: 04	TDR: 000001189930
FILE: \AAA\00123\482	REVISED: 04:24:04 04/26/2022	BY: USODDIL
MTL: -		

BALDOR - RELIANCE®

VERT OPEN 284-6HP W/312 BRG

SH 1 of 1

CD0180

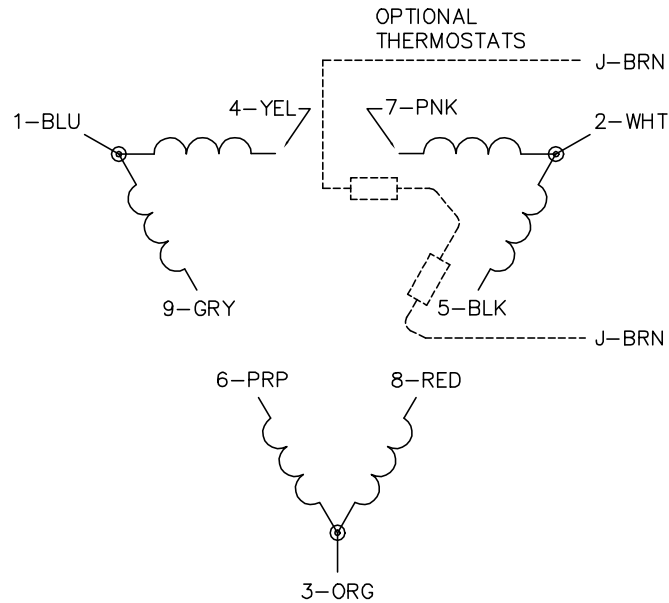

LOW VOLTAGE
(2D)

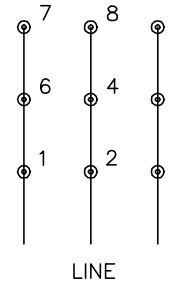

HIGH VOLTAGE
(1D)

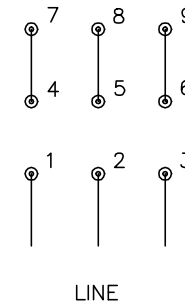

NOTES:

1. INTERCHANGE ANY TWO LINE LEADS TO REVERSE ROTATION.
2. OPTIONAL THERMOSTATS ARE PROVIDED WHEN SPECIFIED.
3. ACTUAL NUMBER OF INTERNAL PARALLEL CIRCUITS MAY BE A MULTIPLE OF THOSE SHOWN ABOVE.
4. LEAD COLORS ARE OPTIONAL. LEADS MUST ALWAYS BE NUMBERED AS SHOWN.

CD0180

REV. DESC: ADD CLASS CONN00000007		
REV. LTR: D	VERSION: 01	TDR: 000001099922
FILE: \AAA\00005\148	REVISED: 10: 25: 29 02/19/2019	BY: ENBRIRO
MTL: -	© □	

BALDOR - RELIANCE®

3PH, DV, 9 LEADS, DELTA CONNECTION

SH 1 of 1