

BALDOR • RELIANCE

Customer information packet

VHEM2546T

60HP, 3550RPM, 3PH, 60HZ, 326HP, 1268M, OPEN, F

Class - None

Division - Not Applicable

Specifications

Enclosure	OPEN
Frame	326HP
Frame Material	Iron
Frequency	60.00 Hz
Haz Area Class and Group	None
Haz Area Division	Not Applicable
Motor Letter Type	Three Phase
Output @ Frequency	60.000 HP @ 60 HZ
Phase	3
Synchronous Speed @ Frequency	3600 RPM @ 60 HZ
Voltage @ Frequency	460.0 V @ 60 HZ 230.0 V @ 60 HZ
Agency Approvals	CSA CSA EEV UR
Ambient Temperature	40 °C
Auxillary Box	No Auxillary Box
Auxillary Box Lead Termination	None
Base Indicator	No Mounting
Bearing Grease Type	Polyrex EM (-20F +300F)
Blower	None
Current @ Voltage	144.000 A @ 208.0 V 66.000 A @ 460.0 V 132.000 A @ 230.0 V
Design Code	A
Drip Cover	Drip Cover
Duty Rating	CONT
Efficiency @ 100% Load	93.6 %
Electrically Isolated Bearing	Not Electrically Isolated
Feedback Device	NO FEEDBACK
Front Face Code	Drip Cover Mounting
Front Shaft Indicator	None

Part detail

Revision	L
Type	AC
Mech. spec.	12E671
Base	
Status	NLA/A
Elec. spec.	12WGY164
Layout	12LYE671
Eff. date	02-21-2022
CD Diagram	CD0180
Poles	02
Leads	9#6
Proprietary	False
Created date	07-13-2015

Heater Indicator	No Heater
High Voltage Full Load Amps	66.0 a
Insulation Class	F
Inverter Code	Inverter Ready
KVA Code	J
Lifting Lugs	Vertical Lifting Lugs
Locked Bearing Indicator	Locked Bearing
Motor Lead Exit	Ko Box
Motor Lead Quantity/Wire Size	9 @ 6 AWG
Motor Lead Termination	Flying Leads
Motor Standards	NEMA
Motor Type	1268M
Mounting Arrangement	F1
Number of Poles	2
Overall Length	33.87 IN
Power Factor	88
Product Family	General Purpose
Pulley End Bearing Type	Ball
Pulley Face Code	P-Base
Pulley Shaft Indicator	P-Base Groove & Key
Rodent Screen	None
Service Factor	1.15
Shaft Diameter	1.625 IN
Shaft Extension Location	Pulley End
Shaft Ground Indicator	No Shaft Grounding
Shaft Rotation	Reversible
Shaft Slinger Indicator	Shaft Slinger
Speed	3550 rpm
Speed Code	Single Speed
Starting Method	Direct on line
Thermal Device - Bearing	NONE (OLD)
Thermal Device - Winding	None
Vibration Sensor Indicator	No Vibration Sensor
Winding Thermal 1	None

Winding Thermal 2

None

Nameplate

NP2138L

CAT.NO.	VHEM2546T	P/N		ENCLOSURE	OPEN		
SPEC.	12E671Y164G1	CC	010A	FRAME	326HP	S/N	
HP	60	CLASS	F	HZ	60		
RPM	3550	PH	3	DES	A		
VOLT	230/460	KVA-CODE	J	ODE BRG	6311	DE BRG	6313
AMP	132/66						
RATING	40C AMB-CONT	GREASE	POLYREX EM				
NEMA-NOM-EFF	93.6	PF	88	SER.F.	1.15		
HTR-VOLTS		HTR-AMPS					

Parts list

Part number	Description	Quantity
SA303902	SA 12E671Y164G1	1.000 ea
RA291054	RA 12E671Y164G1	1.000 ea
10CB3000A52	KOBX MACH W/2.00 NPT, #26	1.000 ea
14GS1000SP	GASKET, CONDUIT BOX	1.000 ea
10XN3118K12	5/16-18 X .75 GRADE 5, ZINC PLATED	4.000 ea
HW1001A31	LOCKWASHER 5/16, ZINC PLT.591 OD, .319 I	4.000 ea
WD1000B25	GND LUG, BURNDY L125HP OR T&B L125HP-BB	1.000 ea
19XW3118G08	.31-18X.50,HEX WSHR HD,TAPTITE 2,GREEN	1.000 ea
12EP1205A01	FREP, MACH - 311 BRG	1.000 ea
12AD2000A01	AIR DEFLECTOR	1.000 ea
51XF2520A08	SCREW, HEX SER SLT HD, ZN 1/4-20 X .50 L	3.000 ea
10XN5013K64	HEX HD SCREW, 1/2-13X4.00GRADE 5, ZINC P	4.000 ea
HW1001A50	LOCKWASHER 1/2, ZINC PLT,.879 OD, .509 I	4.000 ea
HW4600B42	V-RING SLINGER 2.375 X 3.070 X .28 VITON	1.000 ea
HW5100A13	W4627-047 WVY WSHR	1.000 ea
10XN3816K80	3/8-16 X 5.00 HEX HD CAP SCREW GRADE 5 Z	4.000 ea
HW1001A38	LOCKWASHER 3/8, ZINC PLT .688 OD, .382 I	4.000 ea
12EP1506A02	PUEP, MACH - 313 BRG	1.000 ea
10XN5013K44	1/2-13 X 2.75 HEX HD GRADE 5	4.000 ea
HW1001A50	LOCKWASHER 1/2, ZINC PLT,.879 OD, .509 I	4.000 ea
12FH1501A01	DRIP COVER, MACH	1.000 ea
HW3201A13	.62-11 EYEBOLT W/2.00 SHANK	2.000 ea
HW1000A62	WASHER, 5/8" FLAT USS	2.000 ea
HW1001A63	WASHER, 5/8 SPLIT LK, ZN	2.000 ea
10CB3500SP	CONDUIT BOX LID, CAST	1.000 ea
10GS1000SP	GASKET, CONDUIT BOX LID	1.000 ea
51XW2520A12	.25-20 X .75, TAPTITE II, HEX WSHR SLTD	4.000 ea
HW1001A25	LOCKWASHER 1/4, ZINC PLT .493 OD, .255 I	4.000 ea
HW2501G32	KEY, 3/8 SQ X 3.750	1.000 ea
LB1182	WARNING LABEL FOR MOTORS WITH EYENUTS	2.000 ea
HW4500A03	GREASE FITTING, .125 NPT 1610(ALEMITE) 8	1.000 ea

HW4500A17	317400 ALEMITE GREASE RELIEF	1.000 ea
HA4051A00	PLASTIC CAP FOR GREASE FITTING	1.000 ea
MG1025G05	WILKOFAST, 789.227, MED. GRAY CHAR. MET.	0.080 ga
MJ1000A02	GREASE, POLYREX EM EXXON	0.200 lb
HW4500A03	GREASE FITTING, .125 NPT 1610(ALEMITE) 8	1.000 ea
HW4500A17	317400 ALEMITE GREASE RELIEF	1.000 ea
HA4051A00	PLASTIC CAP FOR GREASE FITTING	1.000 ea
85XU0407S04	4X1/4 U DRIVE PIN STAINLESS	4.000 ea
LB1624	WARNING LABEL	1.000 ea
LC0181	CONNECTION LABEL	1.000 ea
NP2138L	ALUM SUPER-E UL PREM CC (300	1.000 ea
14PA1064	PKGP 310-316 FRAME 38X31 1X4 RISER	1.000 ea
MN416A01	TAG-INSTAL-MAINT no wire (2500bx)4/22	1.000 ea

AC Induction Motor Performance Data

Record # 79481

Typical performance - not guaranteed values

Winding: 12WGY164-R001		Type: 1268M	Enclosure: OPEN	
Nameplate Data			460 V, 60 Hz: High Voltage Connection	
Rated Output (HP)	60	Full Load Torque	88.66 LB-FT	
Volts	230/460	Start Configuration	direct on line	
Full Load Amps	132/66	Breakdown Torque	422 LB-FT	
R.P.M.	3550	Pull-up Torque	166 LB-FT	
Hz	60 Phase	Locked-rotor Torque	212 LB-FT	
NEMA Design Code	A KVA Code	Starting Current	707 A	
Service Factor (S.F.)	1.15	No-load Current	25 A	
NEMA Nom. Eff.	93.6 Power Factor	Line-line Res. @ 25°C	0.0732 Ω	
Rating - Duty	40C AMB-CONT	Temp. Rise @ Rated Load	79°C	
S.F. Amps		Temp. Rise @ S.F. Load	94°C	
		Locked-rotor Power Factor	20.7	
		Rotor inertia	5.32 lb-ft ²	

Load Characteristics 460 V, 60 Hz, 60 HP

% of Rated Load	25	50	75	100	125	150	S.F.
Power Factor	54	75	84	88	89	90	89
Efficiency	88.6	92.9	94.1	94.4	94.1	93.9	94.2
Speed	3585	3577	3569	3560	3550	3540	3554
Line amperes	30.2	40.8	53.5	67.9	83.4	100	77.2

ABB Motors and Mechanical Inc.

WINDING # 12WGY164

Typical performance - not guaranteed values.

60 HP 3 PH 60 HZ 3550 RPM 460 V 1268M

TORQUES (LB-FT): PO=422 PU=166 LR=212 LRA=707

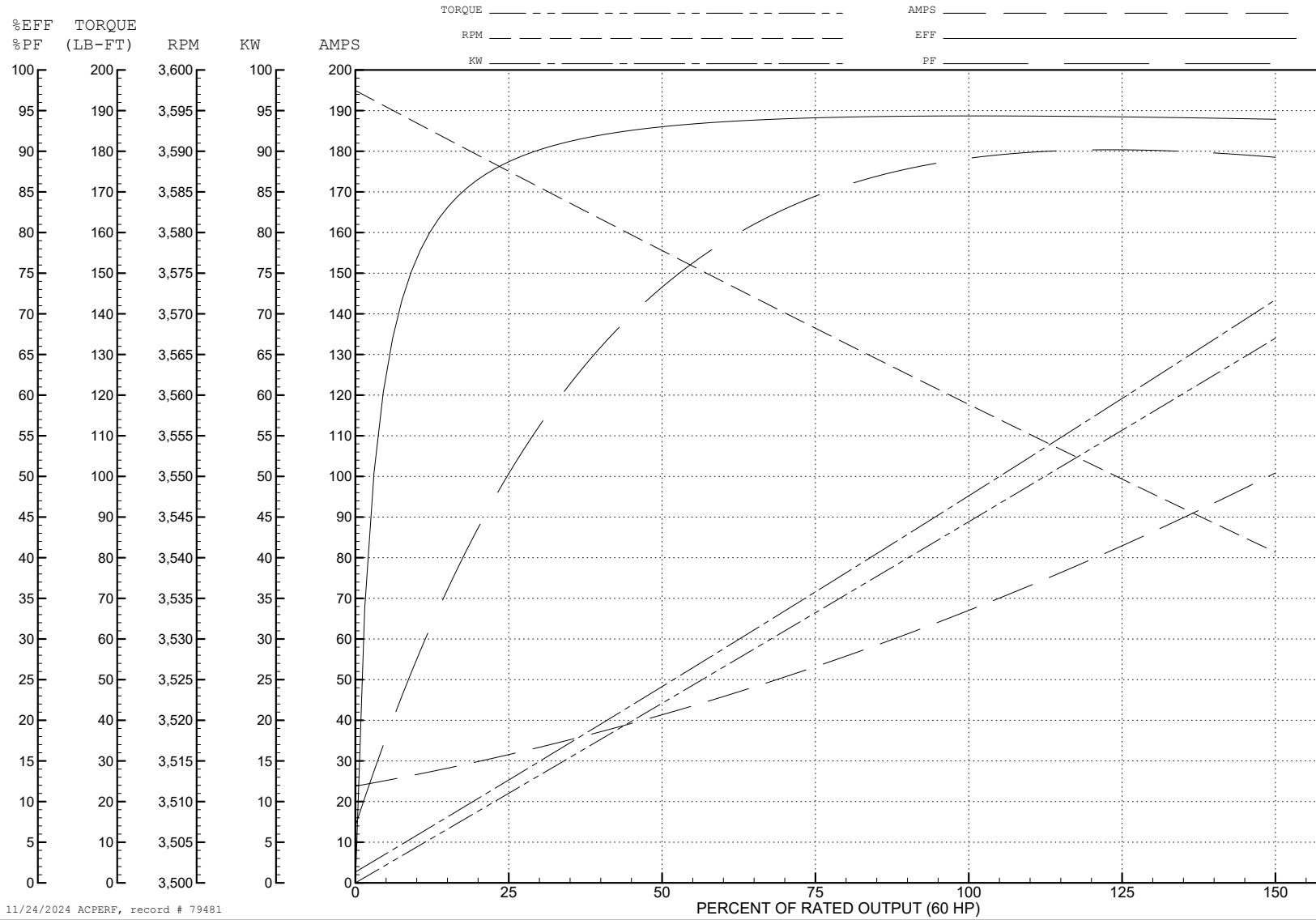

11/24/2024 ACPERF, record # 79481

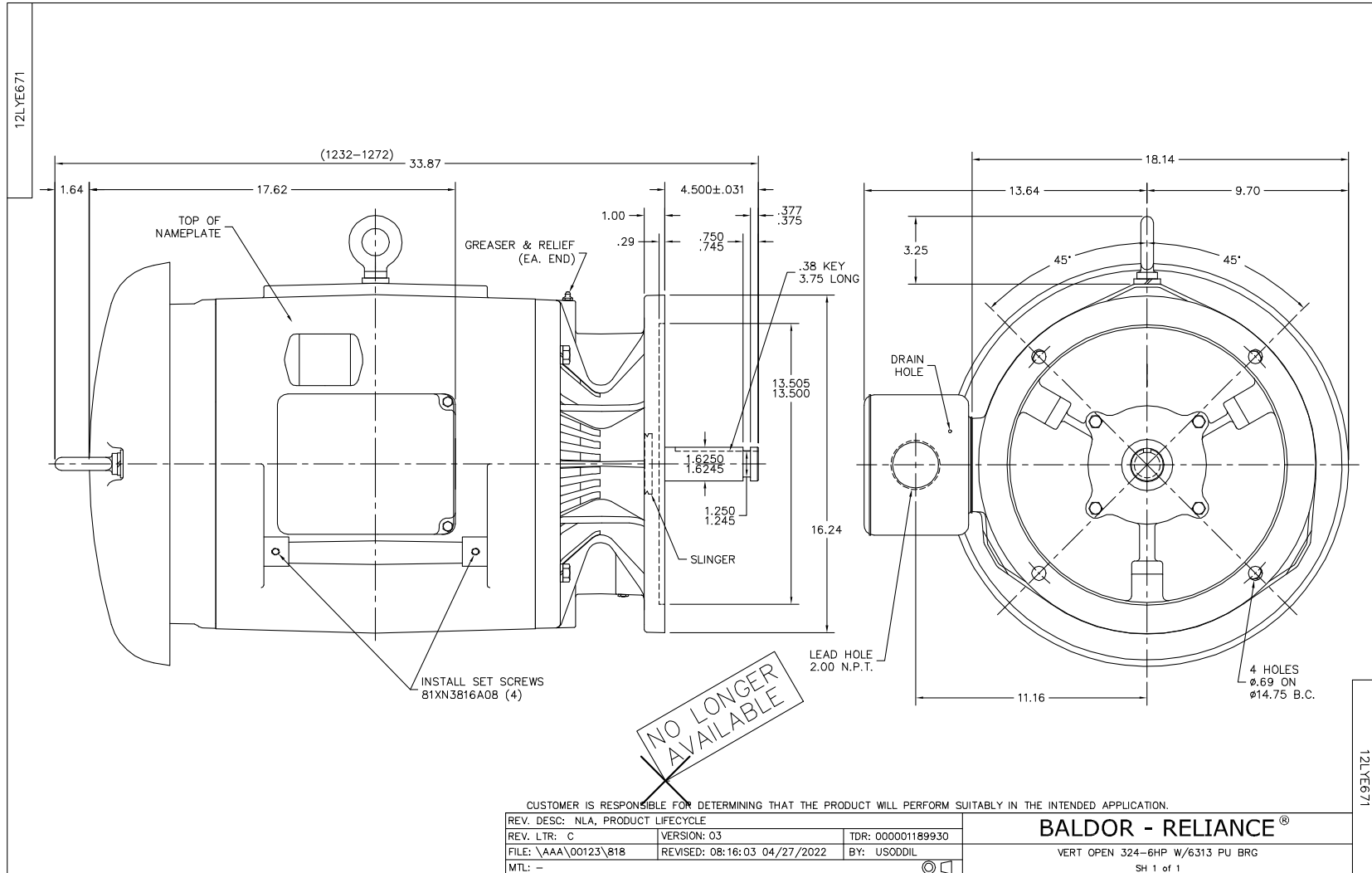

CD0180

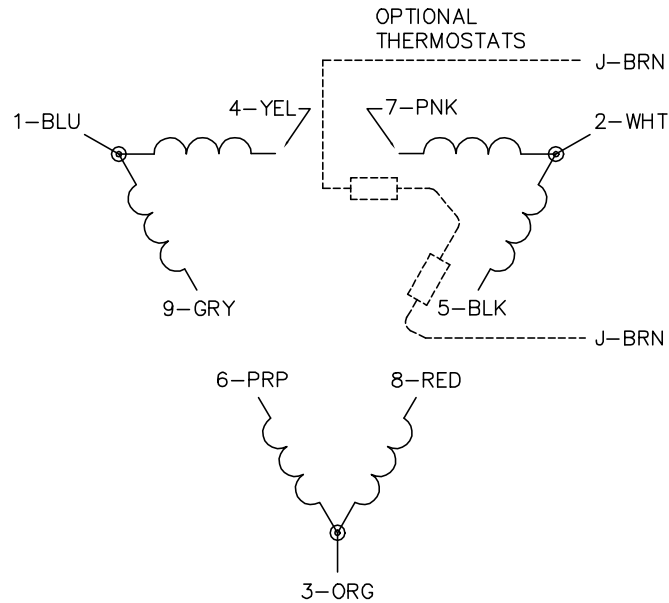

LOW VOLTAGE
(2D)



HIGH VOLTAGE
(1D)



NOTES:

1. INTERCHANGE ANY TWO LINE LEADS TO REVERSE ROTATION.
2. OPTIONAL THERMOSTATS ARE PROVIDED WHEN SPECIFIED.
3. ACTUAL NUMBER OF INTERNAL PARALLEL CIRCUITS MAY BE A MULTIPLE OF THOSE SHOWN ABOVE.
4. LEAD COLORS ARE OPTIONAL. LEADS MUST ALWAYS BE NUMBERED AS SHOWN.

CD0180

REV. DESC: ADD CLASS CONN00000007		
REV. LTR: D	VERSION: 01	TDR: 000001099922
FILE: \AAA\00005\148	REVISED: 10: 25: 29 02/19/2019	BY: ENBRIRO
MTL: -	© □	

BALDOR - RELIANCE®

3PH, DV, 9 LEADS, DELTA CONNECTION

SH 1 of 1