

BALDOR • RELIANCE

Customer information packet

VHEM3211T

3HP, 1765RPM, 3PH, 60HZ, 182HP, 0630M, ODP, W6

Class - None

Division - Not Applicable

Copyright © All product information within this document is subject to ABB Motors and Mechanical Inc. copyright © protection, unless otherwise noted.

11/24/2024 10:46:42 AM

Specifications

Enclosure	ODP
Frame	182HP
Frame Material	Iron
Frequency	60.00 Hz
Haz Area Class and Group	None
Haz Area Division	Not Applicable
Motor Letter Type	Three Phase
Output @ Frequency	3.000 HP @ 60 HZ
Phase	3
Synchronous Speed @ Frequency	1800 RPM @ 60 HZ
Voltage @ Frequency	460.0 V @ 60 HZ 230.0 V @ 60 HZ
Agency Approvals	CSA CSA EEV UR
Ambient Temperature	40 °C
Auxillary Box	No Auxillary Box
Auxillary Box Lead Termination	None
Base Indicator	No Mounting
Bearing Grease Type	Polyrex EM (-20F +300F)
Blower	None
Current @ Voltage	8.400 A @ 230.0 V 8.500 A @ 208.0 V 4.200 A @ 460.0 V
Design Code	B
Drip Cover	Drip Cover
Duty Rating	CONT
Efficiency @ 100% Load	89.5 %
Electrically Isolated Bearing	Not Electrically Isolated
Feedback Device	NO FEEDBACK
Front Face Code	Standard
Front Shaft Indicator	None

Part detail

Revision	F
Type	AC
Mech. spec.	06F867
Base	
Status	NLA/A
Elec. spec.	06WGY462
Layout	06LYF867
Eff. date	04-05-2022
CD Diagram	CD0005
Poles	04
Leads	9#16
Proprietary	False
Created date	07-07-2015

Heater Indicator	No Heater
High Voltage Full Load Amps	4.2 a
Insulation Class	F
Inverter Code	Inverter Ready
KVA Code	K
Lifting Lugs	Vertical Lifting Lugs
Locked Bearing Indicator	Locked Bearing
Motor Lead Exit	Ko Box
Motor Lead Quantity/Wire Size	9 @ 16 AWG
Motor Lead Termination	Flying Leads
Motor Standards	NEMA
Motor Type	0630M
Mounting Arrangement	W6
Number of Poles	4
Overall Length	21.33 IN
Power Factor	74
Product Family	Weather Proof
Pulley End Bearing Type	Ball
Pulley Face Code	P-Base
Pulley Shaft Indicator	Standard
Rodent Screen	None
Service Factor	1.15
Shaft Diameter	1.125 IN
Shaft Extension Location	Pulley End
Shaft Ground Indicator	No Shaft Grounding
Shaft Rotation	Reversible
Shaft Slinger Indicator	Shaft Slinger
Speed	1765 rpm
Speed Code	Single Speed
Starting Method	Direct on line
Thermal Device - Bearing	None
Thermal Device - Winding	None
Vibration Sensor Indicator	No Vibration Sensor
Winding Thermal 1	None

Winding Thermal 2

None

Nameplate

NP1267L									
CAT.NO.	VHEM3211T								
SPEC.	06F867Y462G1								
HP	3								
VOLTS	230/460								
AMP	8.4/4.2								
RPM	1765								
FRAME	182HP	HZ	60	PH	3				
SER.F.	1.15	CODE	K	DES	B	CL	F		
NEMA-NOM-EFF	89.5	PF	74						
RATING	40C AMB-CONT								
CC	010A								
DE	6308	ODE	6205						
ENCL	ODP	SN							

Parts list

Part number	Description	Quantity
SA303717	SA 06F867Y462G1	1.000 ea
RA290859	RA 06F867Y462G1	1.000 ea
HW3201A05	3/8-16 EYEBOLT	1.000 ea
06CB3000B01	KO BOX MACH. W/.75 NPT. HOLE @ 6:00	1.000 ea
06GS1000	GASKET,CONDUIT BOX	1.000 ea
51XW2520A12	SCREW, HEX SER SLT HD, ZN, 1/4-20 X .75	4.000 ea
WD1000B17	T&B CX35TN OR L35P TERMINAL LUG	1.000 ea
10XN2520G06	1/4 20X3/8 HX HD CAP, GREEN	1.000 ea
HW1001A25	LOCKWASHER 1/4, ZINC PLT .493 OD, .255 I	1.000 ea
06EP1200A01	FREP MACH OPEN	1.000 ea
10XN2520A44	1/4 -20 X 2 3/4 HS WS SL SR	4.000 ea
HW1001A25	LOCKWASHER 1/4, ZINC PLT .493 OD, .255 I	4.000 ea
HW4500A03	GREASE FITTING, .125 NPT 1610(ALEMITE) 8	1.000 ea
HW4500A17	317400 ALEMITE GREASE RELIEF	1.000 ea
06AD2000G	AIR DEFLECTOR, 306 OPEN, GREY EPOXY POWD	1.000 ea
51XT0832A08	8-32 X 1/2 TY23 HXWS SLDSR	3.000 ea
HW1001A08	WASHER, #8 SPLT LK, ZN	3.000 ea
HW5100A05	WVY WSHR F/205 & 304 BRGS	1.000 ea
10XN2520A56	1/4-20X 3 1/2 HEX HD CAP X	2.000 ea
HW1001A25	LOCKWASHER 1/4, ZINC PLT .493 OD, .255 I	2.000 ea
06EP1503A02	SPL PU E.P. MACH, W/6308 BRG.	1.000 ea
HW4600A47	CR#13535--NAT#472354 OR TRANSCOM	1.000 ea
10XN2520A36	1/4-20X 2 1/4 HEX HD X	4.000 ea
HW1001A25	LOCKWASHER 1/4, ZINC PLT .493 OD, .255 I	4.000 ea
HW4500A03	GREASE FITTING, .125 NPT 1610(ALEMITE) 8	1.000 ea
HW4500A17	317400 ALEMITE GREASE RELIEF	1.000 ea
HW4500A20	1/8NPT SL PIPE PLUG	1.000 ea
06CB3500	BALDOR CONDUIT BOX LID	1.000 ea
06GS1001	BALDOR CONDUIT BOX GASKET	1.000 ea
51XW2520A12	SCREW, HEX WS SLT, ZN	2.000 ea
HW1001A25	LOCKWASHER 1/4, ZINC PLT .493 OD, .255 I	2.000 ea

06FH1500A01	DRIP COVER FOR 306 OPEN	1.000 ea
HW3201A15	.38-16 EYEBOLT W/1.25 SHANK	2.000 ea
HW1000A38	WASHER, 3/8" FLAT, SAE Z/P	2.000 ea
HW4600C51	31X39X7.5MM FACE SEAL FOR 1.375 DIA. SH	1.000 ea
HW2501E16	KEY, 1/4 SQ X 1.750	1.000 ea
HA7000A02	KEY RETAINER RING, 1 1/8 DIA, 1 3/8 DIA	1.000 ea
LB1386	WARNING LABEL FOR MOTORS WITH EYENUTS	1.000 ea
85XU0407S04	4X1/4 U DRIVE PIN STAINLESS	2.000 ea
LB1115N	LABEL,LIFTING DEVICE (ON ROLLS)	1.000 ea
MJ1000A02	GREASE, POLYREX EM EXXON	0.050 lb
MG1025G29	WILKOFAS, 789.229, DARK CHARCOAL GRAY	0.028 ga
LC0005E01	CONN.DIA./WARNING LABEL (LC0005/LB1119N)	1.000 ea
NP1267L	SS SUPER-E UL EEV CC NEMA PREM LASER ETC	1.000 ea
GOPA1000	PKG GRP, PRINT PK1026A06	1.000 ea
MN416A01	TAG-INSTAL-MAINT no wire (2500bx)4/22	1.000 ea

AC Induction Motor Performance Data

Record # 51698

Typical performance - not guaranteed values

Winding: 06WGY462-R001		Type: 0630M		Enclosure: ODP	
Nameplate Data			460 V, 60 Hz: High Voltage Connection		
Rated Output (HP)		3	Full Load Torque		8.87 LB-FT
Volts		230/460	Start Configuration		direct on line
Full Load Amps		8.4/4.2	Breakdown Torque		37.4 LB-FT
R.P.M.		1765	Pull-up Torque		17.3 LB-FT
Hz	60 Phase	3	Locked-rotor Torque		21.2 LB-FT
NEMA Design Code	B KVA Code	K	Starting Current		32.3 A
Service Factor (S.F.)		1.15	No-load Current		2.43 A
NEMA Nom. Eff.	89.5 Power Factor	74	Line-line Res. @ 25°C		3.77 Ω
Rating - Duty		40C AMB-CONT	Temp. Rise @ Rated Load		24°C
S.F. Amps			Temp. Rise @ S.F. Load		28°C
			Locked-rotor Power Factor		42.9
			Rotor inertia		0.279 LB-FT ²

Load Characteristics 460 V, 60 Hz, 3 HP

% of Rated Load	25	50	75	100	125	150	S.F.
Power Factor	33	53	66	73	79	81	77
Efficiency	80.1	87.6	89.6	89.9	89.7	88.5	89.8
Speed	1791	1783	1775	1766	1756	1745	1760
Line amperes	2.6	2.99	3.54	4.25	4.97	5.83	4.68

ABB Motors and Mechanical Inc.

WINDING # 06WGY462

3 HP 3 PH 60 HZ 1765 RPM 460 V 0630M

Typical performance - not guaranteed values.

TORQUES (LB-FT): PO=37.4 PU=17.3 LR=21.2 LRA=32.3

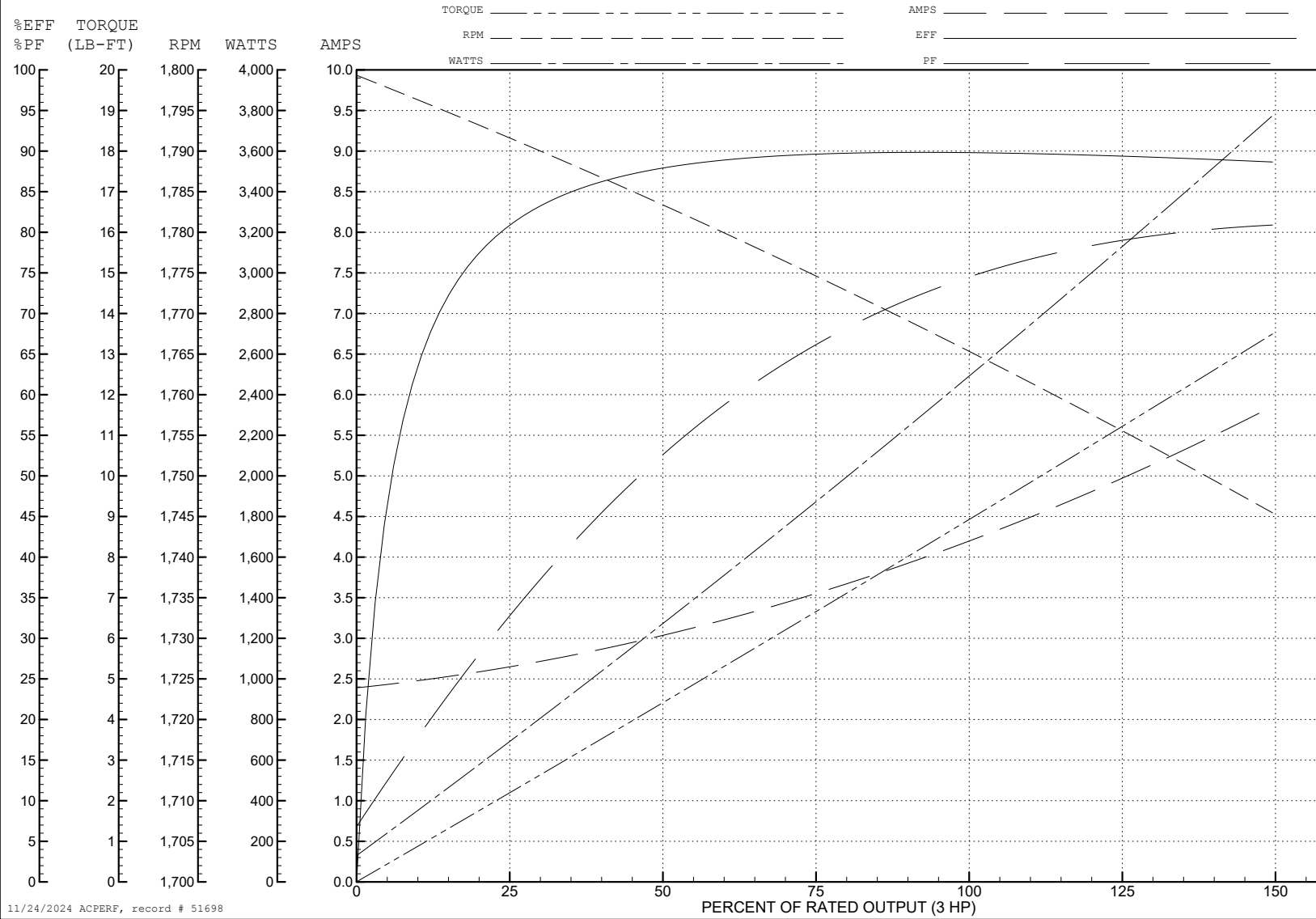

11/24/2024 ACPERF, record # 51698

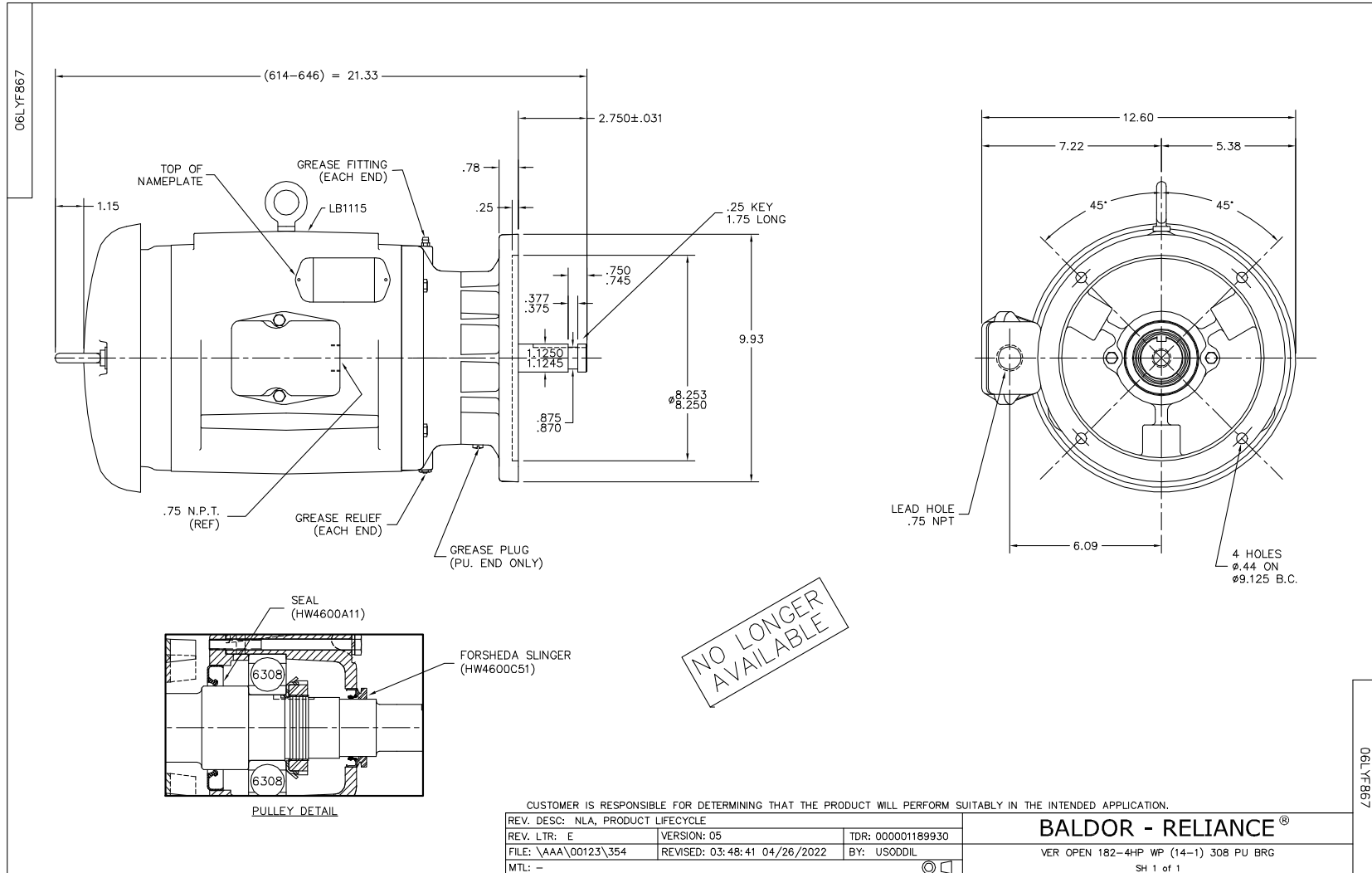

CD0005

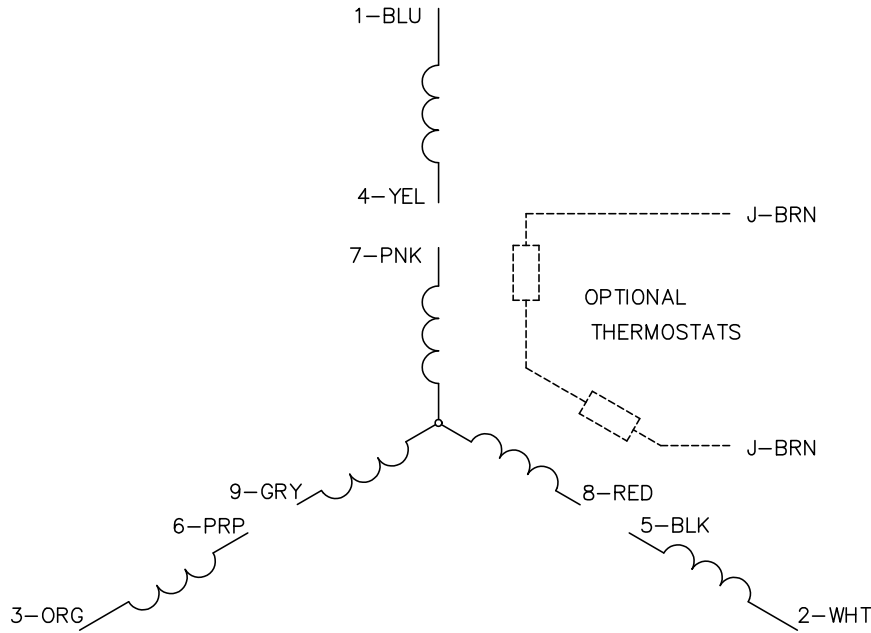

LOW VOLTAGE (2Y)

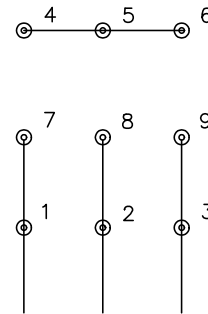

LINE

HIGH VOLTAGE (1Y)

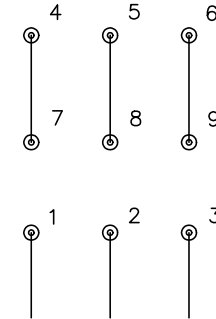

LINE

NOTES:

1. INTERCHANGE ANY TWO LINE LEADS TO REVERSE ROTATION.
2. OPTIONAL THERMOSTATS ARE PROVIDED WHEN SPECIFIED.
3. ACTUAL NUMBER OF INTERNAL PARALLEL CIRCUITS MAY BE A MULTIPLE OF THOSE SHOWN ABOVE.
4. LEAD COLORS ARE OPTIONAL. LEADS MUST ALWAYS BE NUMBERED AS SHOWN.

CD0005

REV. DESC: REVISE TO SHOW OPTIONAL COLORS			
REV. LTR: E	BY: JLP	REVISED: 01/19/99 10:15	TDR: 0171435
S00000		FILE: AAA00005140	MDL: -
		MTL: -	

BALDOR ELECTRIC Co.

3PH, DV, 9 LEADS