



Customer information packet

VUHM3538-5

.5/37KWHP, 1770RPM, 3PH, 60HZ, 56C, 3512M, TEF

Class - None

Division - Not Applicable

Specifications

Enclosure	TEFC
Frame	56C
Frame Material	Steel
Frequency	60.00 Hz
Haz Area Class and Group	None
Haz Area Division	Not Applicable
Motor Letter Type	Three Phase
Output @ Frequency	.500 HP @ 60 HZ
Phase	3
Synchronous Speed @ Frequency	1800 RPM @ 60 HZ
Voltage @ Frequency	575.0 V @ 60 HZ
Agency Approvals	CSA UR WEEE CE
Ambient Temperature	40 °C
Auxillary Box	No Auxillary Box
Auxillary Box Lead Termination	None
Base Indicator	No Mounting
Bearing Grease Type	Polyrex EM (-20F +300F)
Blower	None
Current @ Voltage	.770 A @ 575.0 V
Design Code	B
Drip Cover	No Drip Cover
Duty Rating	CONT
Efficiency @ 100% Load	80.0 %
Electrically Isolated Bearing	Not Electrically Isolated
Feedback Device	NO FEEDBACK
Front Shaft Indicator	None
Heater Indicator	No Heater
High Voltage Full Load Amps	0.8 a
Insulation Class	F

Part detail

Revision	B
Type	AC
Mech. spec.	35X042
Base	
Status	PRD/A
Elec. spec.	35WGG200
Layout	35LYX042
Eff. date	04-16-2024
CD Diagram	CD0006
Poles	04
Leads	3#18
Proprietary	False
Created date	03-11-2022

Inverter Code	Not Inverter
KVA Code	M
Lifting Lugs	No Lifting Lugs
Locked Bearing Indicator	Locked Bearing
Motor Lead Quantity/Wire Size	3 @ 18 AWG
Motor Lead Termination	Flying Leads
Motor Standards	NEMA
Motor Type	3512M
Mounting Arrangement	F3
Number of Poles	4
Overall Length	13.23 IN
Power Factor	62
Product Family	General Purpose
Pulley End Bearing Type	Ball
Pulley Face Code	C-Face
Pulley Shaft Indicator	Standard
Rodent Screen	None
Service Factor	1.15
Shaft Diameter	0.625 IN
Shaft Ground Indicator	No Shaft Grounding
Shaft Rotation	Reversible
Shaft Slinger Indicator	No Slinger
Speed	1770 rpm
Speed Code	Single Speed
Starting Method	Direct on line
Thermal Device - Bearing	None
Thermal Device - Winding	None
Vibration Sensor Indicator	No Vibration Sensor
Winding Thermal 1	None
Winding Thermal 2	None

Nameplate

NP1372L										
CAT.NO.	VUHM3538-5									
SPEC.	35X042G200G1									
HP	.5/37KW									
VOLTS	575									
AMP	0.77									
R.P.M. (1/MIN)	1770									
FRAME	56C		HZ	60		PH	3			
SER.F.	1.15	CODE	M	DES	B	CL	F			
NEMA-NOM-EFF	80	PF	62							
RATING	40C AMB-CONT									
CC			IP44 IC411 16KG							
DE	6205		ODE	6203						
ENCL	TEFC	SN								
	SFA .83									

Parts list

Part number	Description	Quantity
SA409083	SA 35X042G200G1	1.000 ea
RA400629	RA 35X042G200G1	1.000 ea
34FN3002B01	EXTERNAL FAN, PLASTIC, .637/.639 HUB W/	1.000 ea
S/P111-000-002	CORONA TEST, SUPER E MOTORS - FT. SMITH	1.000 ea
NS2512A01	INSULATOR, CONDUIT BOX X	1.000 ea
35CB4007	KOBX,W/PRIMER (WAS REL# 79097-49-C)	1.000 ea
35GS3023	GASKET FOR KOBX 35CB4007, CLSD CELL NEOP	1.000 ea
WD4101A13	STEEL CAPLUG,BP-1 1/8, PLUG D3561S	2.000 ea
51XB1016A05	10-16X5/16HX WA SL SR TYB (F/S)	2.000 ea
11XT1032G04	10-32 X 1/4" GRD SCREW	1.000 ea
HW3001B01	BRASS CUP WASHER, FOR #10 SCREW	1.000 ea
35EP3122K00	MASTER ODE,203 BRG,.683SH,#26 DRN,FH MTG	1.000 ea
HW5100A03	WAVY WASHER (W1543-017)	1.000 ea
35EP3307F00	MASTER DE,205 BRG,.998SH,#26 DRN	1.000 ea
51XN1032A20	10-32 X 1 1/4 HX WS SL SR	2.000 ea
51XB1214A16	12-14X1.00 HXWSSLD SERTYB	1.000 ea
35FH4005A32SP	IEC FH NO GRSR W/3 HOLES - PRIMED	1.000 ea
51XW1032A06	10-32 X .38, TAPTITE II, HEX WSHR SLTD S	3.000 ea
35CB4519	CB LID W/BLACK PRIMER	1.000 ea
35GS3019A01	LEXIDE GASKET, FOR KOBX LID 35CB4519	1.000 ea
51XW0832A07	8-32 X .44, TAPTITE II, HEX WSHR SLTD SE	4.000 ea
HW2501D13	KEY, 3/16 SQ X 1.375	1.000 ea
HA7000A04	KEY RETAINER 0.625 DIA SHAFTS	1.000 ea
85XU0407S04	4X1/4 U DRIVE PIN STAINLESS	2.000 ea
MJ1000A02	GREASE, POLYREX EM EXXON	0.050 lb
MG1025N19	MUNSELL 8.5BG 3.57/2.0, GLOSS 30, B/G,	0.017 ga
HA3100A15	THRUBOLT 10-32 X 8.375	4.000 ea
LB1624	COMBINED WARNING LABEL, ISO/ANSI PICTOGR	1.000 ea
LC0006	CONNECTION LABEL	1.000 ea
MN416A01	TAG-INSTAL-MAINT no wire (2500bx)4/22	1.000 ea
NP1372L	ALUM UL CE UKCA WEEE CC, A60	1.000 ea

36PA1000	PKG GRP, PRINT PK1016A06	1.000 ea
PK3082	STYROFOAM CRADLE	1.000 ea
FE-0000001	ZRTG FE ASSEMBLY	1.000 ea
PE-0000001	ZRTG PE ASSEMBLY	1.000 ea

AC Induction Motor Performance Data

Record # 82252

Typical performance - not guaranteed values

Winding: 35WGG200-R002		Type: 3512M	Enclosure: TEFC			
Nameplate Data			575 V, 60 Hz: Single Voltage Motor			
Rated Output (HP)	.5	Full Load Torque	1.49 LB-FT			
Volts	575	Start Configuration	direct on line			
Full Load Amps	.77	Breakdown Torque	6.26 LB-FT			
R.P.M.	1770	Pull-up Torque	3.25 LB-FT			
Hz	60	Phase	3	Locked-rotor Torque	4.02 LB-FT	
NEMA Design Code	B	KVA Code	M	Starting Current	5.36 A	
Service Factor (S.F.)	1.25	No-load Current	0.636 A			
NEMA Nom. Eff.	80	Power Factor	62	Line-line Res. @ 25°C	68 Ω	
Rating - Duty	40C	AMB-CONT	Temp. Rise @ Rated Load			22°C
S.F. Amps	.87	Temp. Rise @ S.F. Load			27°C	
			Locked-rotor Power Factor	71		
			Rotor inertia	0.0866 lb-ft ²		

Load Characteristics 575 V, 60 Hz, 0.5 HP

% of Rated Load	25	50	75	100	125	150	S.F.
Power Factor	27	41	52	62	69	75	69
Efficiency	56.2	70.6	76.3	78.9	79.9	79.8	79.9
Speed	1792	1786	1779	1771	1763	1755	1763
Line amperes	0.638	0.664	0.713	0.774	0.85	0.946	0.85

ABB Motors and Mechanical Inc.

WINDING # 35WGG200

0.5 HP 3 PH 60 HZ 1770 RPM 575 V 3512M

Typical performance - not guaranteed values.

TORQUES (LB-FT): PO=6.26 PU=3.25 LR=4.02 LRA=5.36

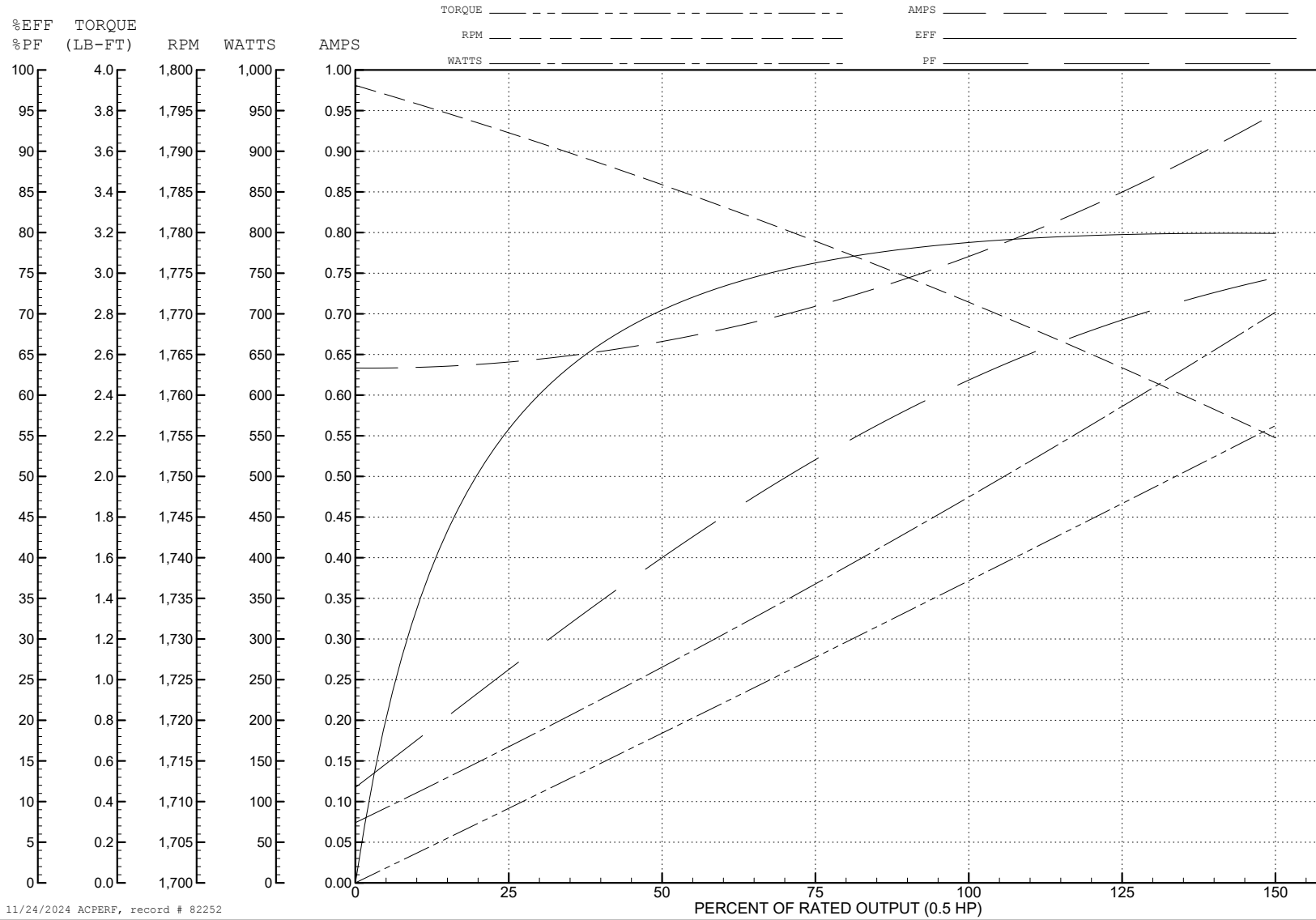

11/24/2024 ACPERF, record # 82252

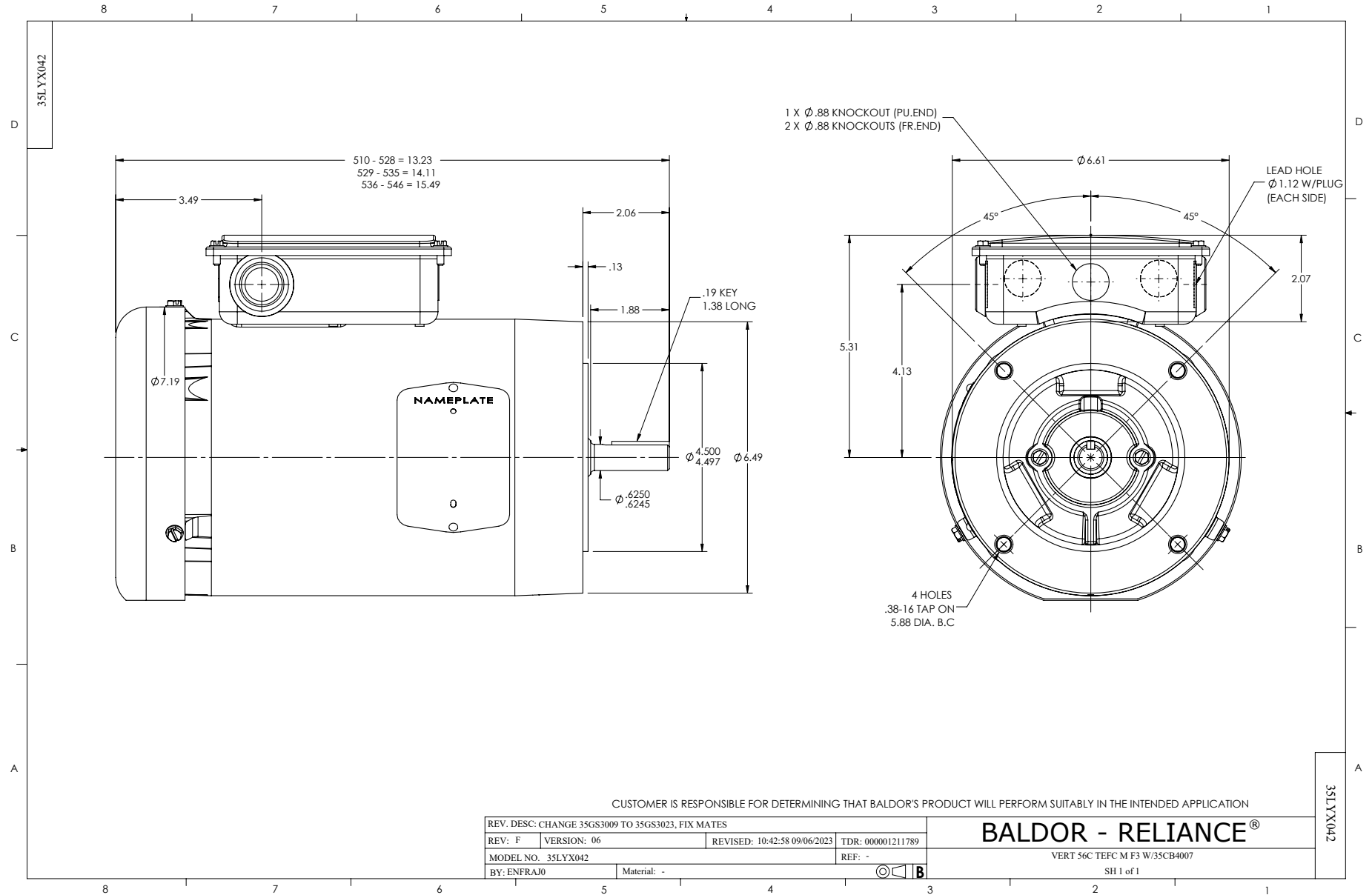

CD0006

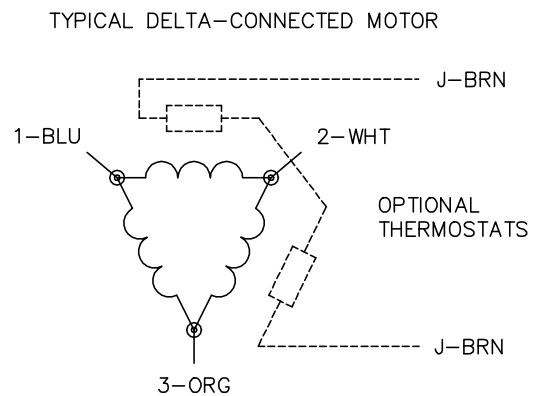

NOTES:

1. THREE LEAD MOTOR MAY BE EITHER WYE CONNECTED OR DELTA CONNECTED.
2. INTERCHANGE ANY TWO LINE LEADS TO REVERSE ROTATION.
3. OPTIONAL THERMOSTATS ARE PROVIDED WHEN SPECIFIED.
4. ACTUAL NUMBER OF INTERNAL PARALLEL CIRCUITS MAY VARY.
5. LEAD COLORS ARE OPTIONAL. LEADS MUST BE NUMBERED AS SHOWN.

CD0006

REV. DESC: ADD CLASS CONN00000007		
REV. LTR: E	VERSION: 01	TDR: 000001099922
FILE: \AAA\00005\141	REVISED: 10:24:49 02/19/2019	BY: ENBRIRO
MTL: -	© □	

BALDOR - RELIANCE®

3PH, SV, 3 LEADS, WYE OR DELTA CONNECTED

SH 1 of 1