



---

# Customer information packet

## VXT3024T

2HP, 1765RPM, 3PH, 60HZ, 145TC, 0530M, TEFC, F1

Class - CLI GP A,B,C,D

Division - Division II

## Specifications

Enclosure	TEFC
Frame	145TC
Frame Material	Iron
Frequency	60.00 Hz
Haz Area Class and Group	CL I GP A,B,C,D
Haz Area Division	Division II
Motor Letter Type	Three Phase
Output @ Frequency	2.000 HP @ 60 HZ
Phase	3
Synchronous Speed @ Frequency	1800 RPM @ 60 HZ
Voltage @ Frequency	208.0 V @ 60 HZ 230.0 V @ 60 HZ 460.0 V @ 60 HZ
Agency Approvals	CCSA US CSA EEV NEMA PREMIUM UR
Ambient Temperature	40 °C
Auxillary Box	No Auxillary Box
Auxillary Box Lead Termination	None
Base Indicator	No Mounting
Bearing Grease Type	Polyrex EM (-20F +300F)
Blower	None
Constant Torque Speed Range	3
Current @ Voltage	5.700 A @ 208.0 V 5.600 A @ 230.0 V 2.800 A @ 460.0 V
Design Code	B
Drip Cover	No Drip Cover
Duty Rating	CONT
Efficiency @ 100% Load	86.5 %
Electrically Isolated Bearing	Not Electrically Isolated

## Part detail

Revision	B
Type	AC
Mech. spec.	05E6082
Base	
Status	PRD/A
Elec. spec.	05WGX904
Layout	05LYE6082
Eff. date	06-28-2024
CD Diagram	CD0005
Poles	04
Leads	9#18
Proprietary	False
Created date	02-20-2023

Feedback Device	NO FEEDBACK
Front Shaft Indicator	None
Haz Area Temp Code	T4
Heater Indicator	No Heater
High Voltage Full Load Amps	2.8 a
Insulation Class	F
Inverter Code	Inverter Ready
KVA Code	L
Lifting Lugs	No Lifting Lugs
Locked Bearing Indicator	Locked Bearing
Motor Lead Quantity/Wire Size	9 @ 18 AWG
Motor Lead Termination	Flying Leads
Motor Standards	NEMA
Motor Type	0530M
Mounting Arrangement	F1
Number of Poles	4
Overall Length	12.54 IN
Power Factor	77
Product Family	General Purpose
Pulley End Bearing Type	Sealed Bearing
Pulley Face Code	C-Face
Pulley Shaft Indicator	Standard
Rodent Screen	None
Service Factor	1.15
Shaft Diameter	0.875 IN
Shaft Ground Indicator	No Shaft Grounding
Shaft Rotation	Reversible
Shaft Slinger Indicator	No Slinger
Speed	1765 rpm
Speed Code	Single Speed
Starting Method	Direct on line
Thermal Device - Bearing	None
Thermal Device - Winding	None
Vibration Sensor Indicator	No Vibration Sensor

Winding Thermal 1

None

---

Winding Thermal 2

None

---

**Nameplate**

<b>NP4163L</b>										
<b>CAT.NO.</b>	VXT3024T					<b>I.P.</b>	54			
<b>SPEC.</b>	05E6082X904G1					<b>ENCL</b>	TEFC			
<b>FRAME</b>	145TC		<b>H.P.</b>	2						
<b>VOLTS</b>	208-230/460		<b>P.F.</b>	77						
<b>F.L. AMPS</b>	5.7-5.6/2.8		<b>RATING</b>	40C AMB-CONT						
<b>R.P.M.</b>	1765									
<b>HZ.</b>	60		<b>PH.</b>	3		<b>CLASS</b>	F			
<b>SER.F.</b>	1.15		<b>DES.</b>	B		<b>SL HZ</b>	1.07			
<b>NEMA NOM. EFF.</b>	86.5		<b>WK2</b>	0.217						
<b>DE</b>	6205		<b>ODE</b>	6203						
<b>MAG. CUR.</b>	2.8-3.3/1.65									
<b>INV TYPE</b>	PWM	<b>CHP</b>	60	<b>TO</b>	90	<b>T. CODE</b>	T4			
<b>CT</b>	3	<b>TO</b>	60	<b>VT</b>	3	<b>TO</b>	60			
<b>CC</b>	010A		<b>SN</b>							
	SFA 6.5-6.3/3.15									
	5.2/2.6A									

## Parts list

Part number	Description	Quantity
SA414846	SA 05E6082X904G1	1.000 ea
RA406615	RA 05E6082X904G1	1.000 ea
06CB3000	BALDOR CONDUIT BOX CAST	1.000 ea
06GS1000	GASKET,CONDUIT BOX	1.000 ea
51XW2520A12	SCREW, HEX SER SLT HD, ZN, 1/4-20 X .75	2.000 ea
11XW1032G06	10-32 X .38, TAPTITE II, HEX WSHR SLTD U	1.000 ea
HW3001B02	BRASS CUP WASHER W/GROUND SYMBOL TAB,	1.000 ea
35EP3122K00	MASTER ODE,203 BRG.,683SH,#26 DRN,FH MTG	1.000 ea
HW5100A03	WAVY WASHER (W1543-017)	1.000 ea
35EP3307F11	F00 W/SLINGER	1.000 ea
51XN1032A20	10-32 X 1 1/4 HX WS SL SR	2.000 ea
HA3100A47	THRUBOLT 10-32 X 7.625	4.000 ea
51XB1214A16	12-14X1.00 HXWSSLD SERTYB	1.000 ea
35FH4005A32SP	IEC FH NO GRSR W/3 HOLES - PRIMED	1.000 ea
51XW1032A06	10-32 X .38, TAPTITE II, HEX WSHR SLTD S	3.000 ea
06CB3500	BALDOR CONDUIT BOX LID	1.000 ea
06GS1001	BALDOR CONDUIT BOX GASKET	1.000 ea
51XW2520A12	.25-20 X .75, TAPTITE II, HEX WSHR SLTD	2.000 ea
HW4600B39SP	V-RING SLINGER 0.550 X 0.790 X .18 VITON	1.000 ea
HW4600B32SP	V-RING SLINGER 1.000 X 1.540 X .24 VITON	1.000 ea
HW2501D13	KEY, 3/16 SQ X 1.375	1.000 ea
HA7000A01	KEY RETAINER 7/8" DIA SHAFT	1.000 ea
85XU0407S04	4X1/4 U DRIVE PIN STAINLESS	2.000 ea
MJ1000A02	GREASE, POLYREX EM EXXON	0.050 lb
35FN3002A05SP	EXFN, PLASTIC, 6.376 OD, .638 ID	1.000 ea
MG1025L14	WILKOFASST, 776.14, GRUNDFOS BLACK	0.022 ga
NP4163L	SS CP INV DIV-2 UL CSA-C US EEV PREM, DI	1.000 ea
LC0005E01	CONN.DIA./WARNING LABEL (LC0005/LB1119N)	1.000 ea
LB1449	DIV-2/NEC WARNING LABEL	1.000 ea
36PA1000	PKG GRP, PRINT PK1016A06	1.000 ea
PK3082	STYROFOAM CRADLE	1.000 ea

---

MN416A01	TAG-INSTAL-MAINT no wire (2500bx)4/22	1.000 ea
FE-0000001	ZRTG FE ASSEMBLY	1.000 ea

---

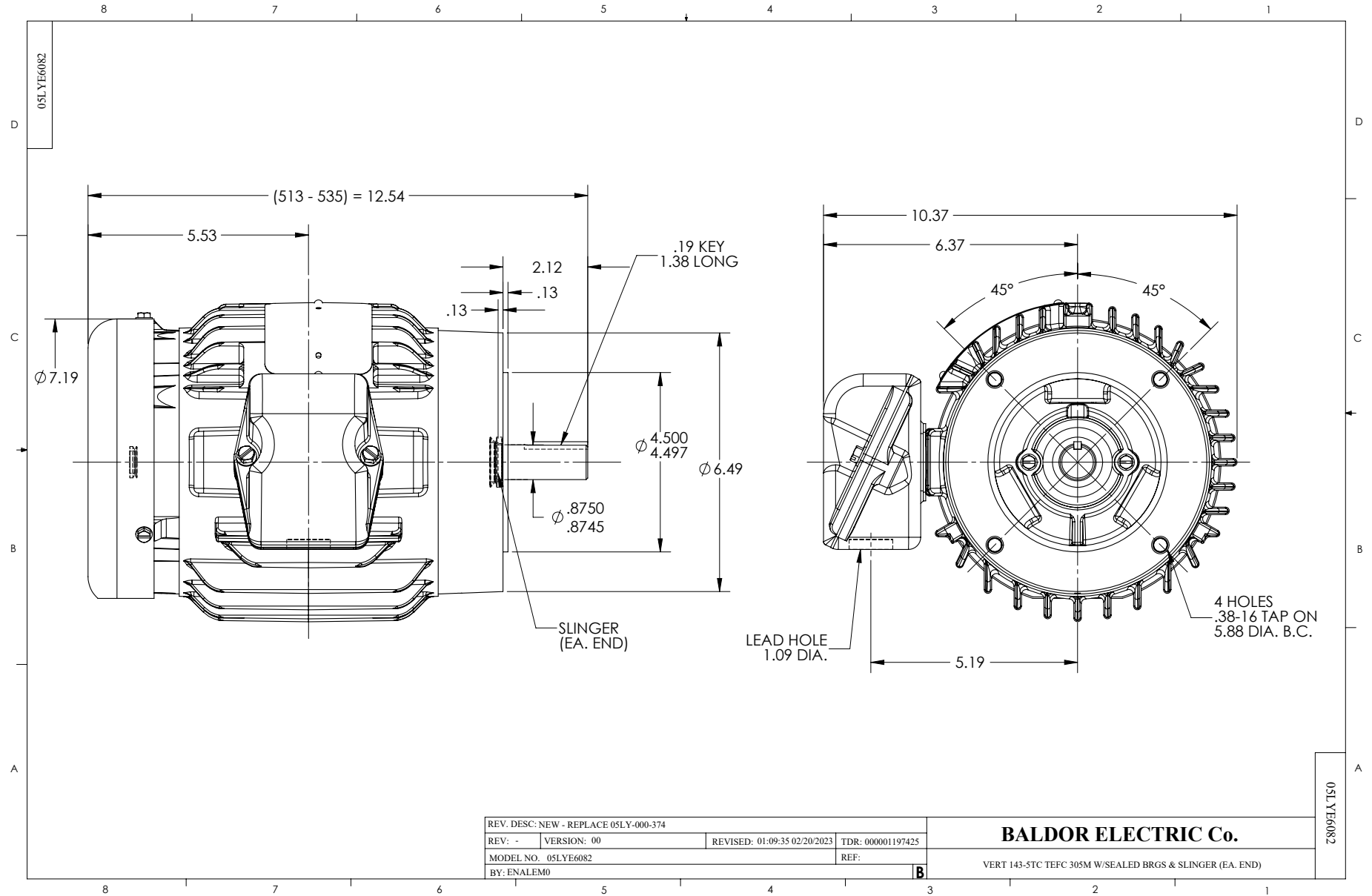



CD0005

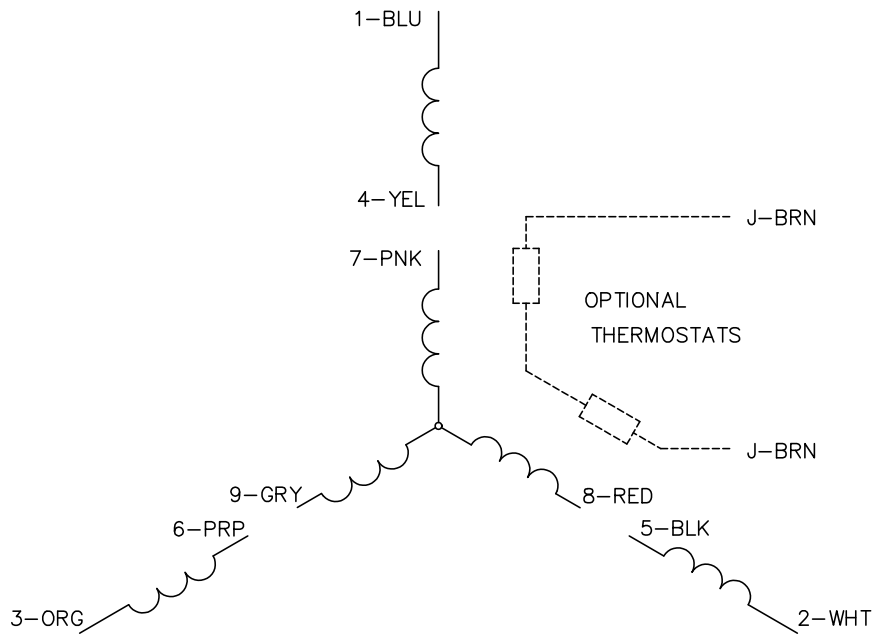

LOW VOLTAGE  
(2Y)



LINE

HIGH VOLTAGE  
(1Y)



LINE

NOTES:

1. INTERCHANGE ANY TWO LINE LEADS TO REVERSE ROTATION.
2. OPTIONAL THERMOSTATS ARE PROVIDED WHEN SPECIFIED.
3. ACTUAL NUMBER OF INTERNAL PARALLEL CIRCUITS MAY BE A MULTIPLE OF THOSE SHOWN ABOVE.
4. LEAD COLORS ARE OPTIONAL. LEADS MUST ALWAYS BE NUMBERED AS SHOWN.

CD0005

REV. DESC: REVISE TO SHOW OPTIONAL COLORS			
REV. LTR: E	BY: JLP	REVISED: 01/19/99 10:15	TDR: 0171435
S00000		FILE: AAA00005140	MDL: -
		MTL: -	

**BALDOR ELECTRIC Co.**

3PH, DV, 9 LEADS