



---

# Customer information packet

## XT31504T-4

150HP, 1785RPM, 3PH, 60HZ, 445T, A4488M, TEFC

Class - CLI GP A,B,C,D

Division - Division II

## Specifications

Enclosure	TEFC
Frame	445T
Frame Material	Iron
Frequency	60.00 Hz
Haz Area Class and Group	CLI GP A,B,C,D
Haz Area Division	Division II
Motor Letter Type	Three Phase
Output @ Frequency	150.000 HP @ 60 HZ
Phase	3
Synchronous Speed @ Frequency	1800 RPM @ 60 HZ
Voltage @ Frequency	460.0 V @ 60 HZ
Agency Approvals	UR NEMA_PREMIUM NEMA PREMIUM CCSAUSEEV
Ambient Temperature	40 °C
Auxillary Box	No Auxillary Box
Base Indicator	Rigid
Bearing Grease Type	Polyrex EM (-20F +300F)
Current @ Voltage	169.000 A @ 460.0 V
Design Code	B
Drip Cover	No Drip Cover
Duty Rating	CONT
Efficiency @ 100% Load	95.8 %
Feedback Device	NO FEEDBACK
Heater Indicator	No Heater
High Voltage Full Load Amps	169.0 a
Insulation Class	F
Inverter Code	Inverter Ready
IP Rating	NONE
KVA Code	F
Max Speed	3600 rpm

## Part detail

Revision	B
Type	AC
Mech. spec.	
Base	
Status	PRD/A
Elec. spec.	A44WG3335
Layout	617427-476
Eff. date	07-08-2024
CD Diagram	416820-036
Poles	04
Leads	3#1/0
Proprietary	False
Created date	12-17-2020

<b>Motor Lead Quantity/Wire Size</b>	3 @ 1/0 AWG
<b>Motor Standards</b>	NEMA
<b>Motor Type</b>	A4488M
<b>Mounting Arrangement</b>	F1
<b>Number of Poles</b>	4
<b>Overall Length</b>	44.97 IN
<b>Power Factor</b>	86
<b>Product Family</b>	General Industrial
<b>Pulley End Bearing Type</b>	Ball
<b>Pulley Face Code</b>	Standard
<b>Service Factor</b>	1.15
<b>Shaft Diameter</b>	3.375 IN
<b>Shaft Ground Indicator</b>	No Shaft Grounding
<b>Shaft Rotation</b>	Reversible
<b>Shaft Slinger Indicator</b>	Shaft Slinger
<b>Speed</b>	1785 rpm
<b>Speed Code</b>	Single Speed
<b>Starting Method</b>	Direct on line
<b>Thermal Device - Bearing</b>	None
<b>Thermal Device - Winding</b>	None

**Nameplate**

**NP4152LUA**

<b>CAT #</b>	XT31504T-4			<b>SER</b>				<b>CC</b>	010A			
<b>SPEC</b>	A44-9304-3335			<b>RATING</b>	40C AMB-CONT							
<b>HZ</b>	<b>VOLTS</b>		<b>AMPS</b>		<b>RPM</b>	<b>HP</b>	<b>CODE</b>	<b>SF</b>	<b>DES</b>	<b>PF</b>	<b>NEMA NOM. EFF</b>	
60	460		169		1785	150	F	1.15	B	86 %	95.8 %	
										%	%	
<b>PH</b>	3	<b>CL</b>	F	<b>MAX RPM</b>	3600	<b>MAX CORR KVAR</b>	30					
<b>BRG</b>	<b>DE</b>	6318	<b>ODE</b>	6318	<b>ENCL</b>	TEFC	<b>FR</b>	445T	<b>IP</b>	54		
<b>GREASE</b>	POLYREX EM						<b>MTR WT</b>	LBS				
	<b>CL I DIV 2 GRPS A,B,C,D</b>				<b>CL I ZONE 2 GRPS</b>			<b>IIA,IIB,IIC</b>		<b>TEMP T</b>	200	<b>C</b>
<b>INV READY</b>	<b>CT</b>	4:1	<b>HZ</b>	15-60	<b>VT</b>	0-60	<b>HZ</b>	1000:1	<b>CHP</b>	60-90	<b>HZ</b>	1:1.5
<b>INV TEMP CL</b>	T3	<b>C</b>	<b>USABLE AT</b>	50HZ 125HP 380V 170A						1.00		

## Parts list

Part number	Description	Quantity
SA388896	SA A44-9304-3335	1.000 ea
RA379261	RA A44-9304-3335	1.000 ea
421948051	LABEL, MYLAR	1.000 ea
000692000VD	LABEL WARNING	1.000 ea
LB1449	DIV-2/NEC WARNING LABEL	1.000 ea
NP4152LUA	SS CP XT CLI DIV2 UR CSA-C US-EEV NEMA P	1.000 ea
412118006A	DRAIN	2.000 ea
034690005AB	PPLG 3/4 PLATED	1.000 ea
089490099A	G28 BRKT 089490098WCA KB	1.000 ea
415072001B	CLAMP	1.000 ea
083199126RA	G28 MOLDED FAN COVER W/BAFFLE ASSEMBLY	1.000 ea
034180014DA	KEY 1/4X1/4X1-3/4 L	1.000 ea
078548001R	FAN KB 234/150 (84) 400	1.000 ea
004824015A	GREASE POLYREX EM	1.160 lb
032018020FK	HHCS 3/4-10X2-1/2 PLTD.	4.000 ea
032018008CK	HHCS 3/8-16X1L PLATED	4.000 ea
032018030DK	HHCS 1/2-13X3-3/4 PLTD.	3.000 ea
034631002AB	BUSH 1/4 TO 1/8 PLTD.	1.000 ea
415096002A	CPLG 1/8 HEX TYPE	1.000 ea
415045002A	SLGR	1.000 ea
410700004A	WSHR	1.000 ea
035000001G	GREASE RELIEF FITTING, ALEMITE 317400	1.000 ea
034017014AB	LCKW 3/8 STD. PLATED	4.000 ea
034530064BB	P/NIP 1/4X8 PLATED	1.000 ea
034530064AB	P/NIP 1/8 X 8" L Pipe Nipple	1.000 ea
032620016LA	SOCKET SET SCREW-449	3.000 ea
034631002AB	BUSH 1/4 TO 1/8 PLTD.	1.000 ea
034530044BB	P/NIP 1/4X5-1/2L PLT	1.000 ea
702623013A	THERMAL BARRIER -- G28 -- BRACKET MTD	1.000 ea
032018004BK	HHCS 5/16-18X1/2 PLATED	3.000 ea
034017013AB	LCKW 5/16 STD. PLATED	3.000 ea

089490099A	G28 BRKT 089490098WCA KB	1.000 ea
032018020FK	HHCS 3/4-10X2-1/2 PLTD.	4.000 ea
032018030DK	HHCS 1/2-13X3-3/4 PLTD.	3.000 ea
415045002A	SLGR	1.000 ea
034530044AB	P/NIP 1/8X5-1/2L GALV.	1.000 ea
415096002A	CPLG 1/8 HEX TYPE	1.000 ea
035000001G	GREASE RELIEF FITTING, ALEMITE 317400	1.000 ea
032620016LA	SOCKET SET SCREW-449	3.000 ea
415915007K	GASK, 26" LAC	1.000 ea
702658001A	CONDUIT BOX, E440	1.000 ea
702658002A	+C/BOX CVR, PAINTED 440	1.000 ea
406056008A	GASKET, TERBD 440	1.000 ea
418153001A	GASK 440	1.000 ea
418150003A	GREASE FITTING CAP	1.000 ea
032018008DK	HHCS 1/2-13X1 PLATED	4.000 ea
035000001A	ALFTG 1/8" 1610-BL	1.000 ea
415000103D	T/LUG #4AWG-1/0AWG W/HOLE FOR .250 BOLT	1.000 ea
033512006LB	HHTTS 1/4-20X3/4 PLTD.	8.000 ea
406099000A	PLUG - FAN COVER 320-440	1.000 ea
033512004LB	HHTTS 1/4-20X1/2 PLTD.	1.000 ea
035000001A	ALFTG 1/8" 1610-BL	1.000 ea
418150003A	GREASE FITTING CAP	1.000 ea
MG1025L14	WILKOFAS, 776.14, GRUNDFOS BLACK	0.440 ga
033775004EA	DRSCR #6-1/4 304 S.S.	2.000 ea
034180054KA	7/8 SQ X 6.75 KEY	1.000 ea
604797045	STD. 400 FRAME SKID	1.000 ea
032510024D	CARRIAGE BOLT - 444	2.000 ea
034001016AB	WSHR .562ID 1.375OD .109	2.000 ea
034001014AB	FLAT WASHER 3/8"PLATED	2.000 ea
033300014AC	HEX NUT, SHIPPING - 400	2.000 ea
604799003C	PLASTIC BAG 42X32X46	1.000 ea











617427-476

**DUTY MASTER ALTERNATING CURRENT MOTORS**  
SQUIRREL-CAGE INDUCTION

ENCLOSURE: TOTALLY ENCLOSED

MOUNTING: FOOT, F-1 SIDE

FRAME G444T  
INCLUDES G445T FRAME MOUNTING HOLES

STEEL MAIN CONDUIT BOX

COOLING: FAN COOLED

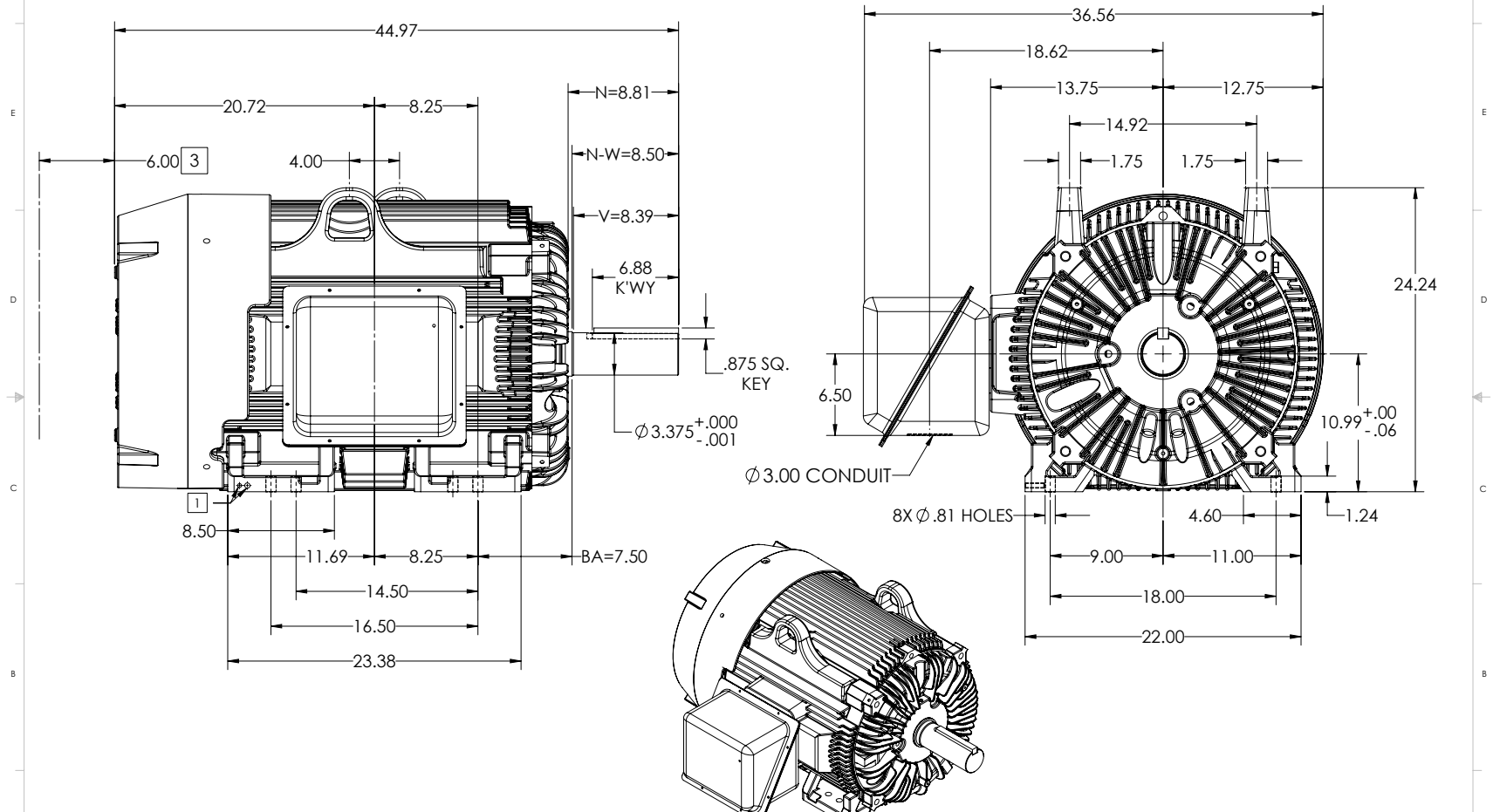

- 1 GROUND HOLES QTY 1 1/2-13 TAP; QTY 1 3/8-16 TAP
- 2 MOTOR WEIGHTS MAY VARY BY 15% DEPENDING ON RATING.
- 3 OBSTRUCTION MUST NOT ENCROACH ON AIR INLET

2 WEIGHT (LBS): 2130

DIMENSIONS ARE IN INCHES  
CUSTOMER IS RESPONSIBLE FOR DETERMINING THAT MOTOR PERFORMANCE IS SUITABLE IN THE APPLICATION.

SHEET NUMBER  
**1 OF 1**  
9LF-272L19

IF MOUNTING CLEARANCE DETAILS ARE REQUIRED, CONSULT FACTORY.  
MAXIMUM PERMISSIBLE SHAFT RUNOUT WHEN MEASURED AT END OF  
STANDARD SHAFT EXTENSION IS .003" T.I.R. TO 5 INCH DIA.

REV. DESC: NEW DRAWING			
REV: -	VERSION: 00	REVISED: 10/03/28 04/18/2015	TDR: 00000919063
MODEL NO. 617427-476		REF:	
BY: RAGRA	Material:	C	

**BALDOR**

G445T-444T TEFC FT - SD/CNTR - STEEL C/BOX

617427-476

416820-036

A-C MOTOR  
CONNECTION DIAGRAM  
STANDARD 3 LEAD CONNECTED



(N.P. 1575-BA)

REV. DESC: LOADED TO BUS, C/R 335225		
REV. LTR: -	VERSION: 00	TDR: 000000538207
FILE: \MGA\00000\682	REVISED: 11:54:06 04/30/2010	
MTL: -	BY: RAGRA	

**BALDOR**

CONN DIAG - STANDARD 3 LEAD  
SH 1 of 1

416820-036