



---

# Customer information packet

## XT32502TS-4

250HP, 3570RPM, 3PH, 60HZ, 449TS, A44112M, TEF

Class - CLI GP A,B,C,D

Division - Division II

## Specifications

Enclosure	TEFC
Frame	449TS
Frame Material	Iron
Frequency	60.00 Hz
Haz Area Class and Group	CLI GP A,B,C,D
Haz Area Division	Division II
Motor Letter Type	Three Phase
Output @ Frequency	250.000 HP @ 60 HZ
Phase	3
Synchronous Speed @ Frequency	3600 RPM @ 60 HZ
Voltage @ Frequency	460.0 V @ 60 HZ
Agency Approvals	UR NEMA_PREMIUM NEMA PREMIUM CCSAUSEEV
Ambient Temperature	40 °C
Auxillary Box	No Auxillary Box
Base Indicator	Rigid
Bearing Grease Type	Polyrex EM (-20F +300F)
Current @ Voltage	269.000 A @ 460.0 V
Design Code	B
Drip Cover	No Drip Cover
Duty Rating	CONT
Efficiency @ 100% Load	95.8 %
Feedback Device	NO FEEDBACK
Heater Indicator	No Heater
High Voltage Full Load Amps	269.0 a
Insulation Class	F
Inverter Code	Inverter Ready
IP Rating	NONE
KVA Code	G
Max Speed	4500 rpm

## Part detail

Revision	B
Type	AC
Mech. spec.	
Base	
Status	PRD/A
Elec. spec.	A44WG1559
Layout	617427-460
Eff. date	07-08-2024
CD Diagram	416820-036
Poles	02
Leads	3#2/0 (02 per group)
Proprietary	False
Created date	12-22-2020

<b>Motor Lead Quantity/Wire Size</b>	6 @ 2/0 AWG
<b>Motor Standards</b>	NEMA
<b>Motor Type</b>	A44112M
<b>Mounting Arrangement</b>	F1
<b>Number of Poles</b>	2
<b>Overall Length</b>	49.46 IN
<b>Power Factor</b>	90
<b>Product Family</b>	General Industrial
<b>Pulley End Bearing Type</b>	Ball
<b>Pulley Face Code</b>	Standard
<b>Service Factor</b>	1.15
<b>Shaft Diameter</b>	2.375 IN
<b>Shaft Ground Indicator</b>	No Shaft Grounding
<b>Shaft Rotation</b>	Reversible
<b>Shaft Slinger Indicator</b>	Shaft Slinger
<b>Speed</b>	3570 rpm
<b>Speed Code</b>	Single Speed
<b>Starting Method</b>	Direct on line
<b>Thermal Device - Bearing</b>	None
<b>Thermal Device - Winding</b>	None

**Nameplate**

**NP4152LUA**

<b>CAT #</b>	XT32502TS-4			<b>SER</b>				<b>CC</b>	010A				
<b>SPEC</b>	A44-7676-1559			<b>RATING</b>	40C AMB-CONT								
<b>HZ</b>	<b>VOLTS</b>		<b>AMPS</b>	<b>RPM</b>	<b>HP</b>	<b>CODE</b>	<b>SF</b>	<b>DES</b>	<b>PF</b>	<b>NEMA NOM. EFF</b>			
60	460		269	3570	250	G	1.15	B	90 %	95.8 %			
									%	%			
<b>PH</b>	3	<b>CL</b>	F	<b>MAX RPM</b>	4500	<b>MAX CORR KVAR</b>	28						
<b>BRG</b>	<b>DE</b>	6313	<b>ODE</b>	6313	<b>ENCL</b>	TEFC	<b>FR</b>	449TS	<b>IP</b>	54			
<b>GREASE</b>	POLYREX EM						<b>MTR WT</b>	<b>LBS</b>					
	<b>CL I DIV 2 GRPS A,B,C,D</b>				<b>CL I ZONE 2 GRPS</b>			<b>IIA,IIB,IIC</b>		<b>TEMP T</b>	230	<b>C</b>	
<b>INV READY</b>	<b>CT</b>	2:1	<b>HZ</b>	30-60	<b>VT</b>	0-60	<b>HZ</b>	1000:1	<b>CHP</b>	60-75	<b>HZ</b>	1:1.25	
<b>INV TEMP CL</b>	T2C	<b>C</b>	<b>USABLE AT</b>	50HZ 200HP 380V 261A						1.00			

## Parts list

Part number	Description	Quantity
SA389084	SA A44-7676-1559	1.000 ea
RA379447	RA A44-7676-1559	1.000 ea
421948051	LABEL, MYLAR	1.000 ea
000692000FF	N/P	1.000 ea
000692000VD	LABEL WARNING	1.000 ea
LB1449	DIV-2/NEC WARNING LABEL	1.000 ea
NP4152LUA	SS CP XT CLI DIV2 UR CSA-C US-EEV NEMA P	1.000 ea
412118006A	DRAIN	2.000 ea
034690005AB	PPLG 3/4 PLATED	1.000 ea
089490097A	BRKT 089490102WCA	1.000 ea
415072001B	CLAMP	1.000 ea
083199126RA	G28 MOLDED FAN COVER W/BAFFLE ASSEMBLY	1.000 ea
034180014DA	KEY 1/4X1/4X1-3/4 L	1.000 ea
702676001D	FAN 250-440	1.000 ea
004824015A	GREASE POLYREX EM	0.540 lb
032018020FK	HHCS 3/4-10X2-1/2 PLTD.	4.000 ea
032018008CK	HHCS 3/8-16X1L PLATED	4.000 ea
032018022CK	HHCS 3/8-16X2-3/4 PLTD	3.000 ea
415096002A	CPLG 1/8 HEX TYPE	1.000 ea
415045002E	SLGR	1.000 ea
410700004F	WSHR	1.000 ea
035000001G	GREASE RELIEF FITTING, ALEMITE 317400	1.000 ea
034017014AB	LCKW 3/8 STD. PLATED	4.000 ea
034530072AB	P/NIP 1/8X9"L Threaded both ends	1.000 ea
034631002AB	BUSH 1/4 TO 1/8 PLTD.	1.000 ea
034530072BB	PIPE NIPPLE,DE - 440-BS	1.000 ea
032620016LA	SOCKET SET SCREW-449	3.000 ea
034631002AB	BUSH 1/4 TO 1/8 PLTD.	1.000 ea
034530072BB	PIPE NIPPLE,DE - 440-BS	1.000 ea
702623012A	THERMAL BARRIER, G28	1.000 ea
032018004BK	HHCS 5/16-18X1/2 PLATED	3.000 ea

034000013AB	WSHR 5/16" PLATED-440	3.000 ea
089490097A	BRKT 089490102WCA	1.000 ea
032018020FK	HHCS 3/4-10X2-1/2 PLTD.	4.000 ea
032018022CK	HHCS 3/8-16X2-3/4 PLTD	3.000 ea
415045002E	SLGR	1.000 ea
034530072AB	P/NIP 1/8X9"L Threaded both ends	1.000 ea
415096002A	CPLG 1/8 HEX TYPE	1.000 ea
035000001G	GREASE RELIEF FITTING, ALEMITE 317400	1.000 ea
032018006BK	HHCS 5/16-18X3/4 PLATED	3.000 ea
034017013AB	LCKW 5/16 STD. PLATED	3.000 ea
702623022A	G28 AIR DEFLECTOR DRIVE END -- PLASTIC	1.000 ea
034001013AB	FLTW BAFFLE	3.000 ea
415915007K	GASK, 26" LAC	1.000 ea
702658001B	+C/BOX, PAINTED 440	1.000 ea
702658002A	+C/BOX CVR, PAINTED 440	1.000 ea
406056008A	GASKET, TERBD 440	1.000 ea
418153001A	GASK 440	1.000 ea
418150003A	GREASE FITTING CAP	1.000 ea
032018008DK	HHCS 1/2-13X1 PLATED	4.000 ea
035000001A	ALFTG 1/8" 1610-BL	1.000 ea
415000103D	T/LUG #4AWG-1/0AWG W/HOLE FOR .250 BOLT	1.000 ea
033512006LB	HHTTS 1/4-20X3/4 PLTD.	8.000 ea
406099000A	PLUG - FAN COVER 320-440	1.000 ea
033512004LB	HHTTS 1/4-20X1/2 PLTD.	1.000 ea
035000001A	ALFTG 1/8" 1610-BL	1.000 ea
418150003A	GREASE FITTING CAP	1.000 ea
MG1025L14	WILKOFAS, 776.14, GRUNDFOS BLACK	0.500 ga
033775004EA	DRSCR #6-1/4 304 S.S.	2.000 ea
034180024HA	KEY 5/8X5/8X3 L	1.000 ea
604797056	400-447 FRAME 60 X 42	1.000 ea
032510026D	CARRIAGE BOLT - 440	2.000 ea
034001014AB	FLAT WASHER 3/8"PLATED	2.000 ea
034001016AB	WSHR .562ID 1.375OD .109	2.000 ea
033300014AC	HEX NUT, SHIPPING - 400	2.000 ea

604799003C

PLASTIC BAG 42X32X46

1.000 ea

---









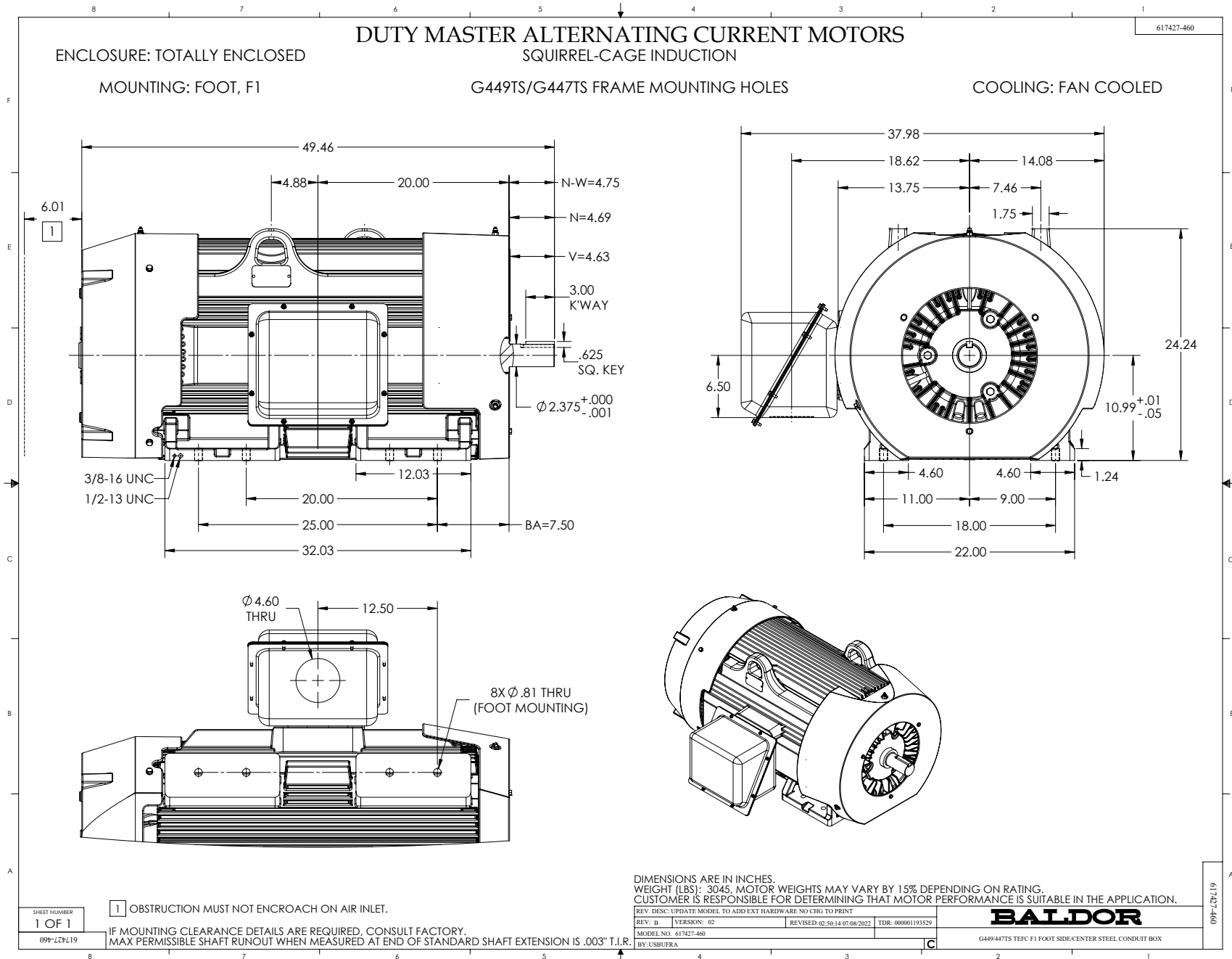

416820-036

A-C MOTOR  
CONNECTION DIAGRAM  
STANDARD 3 LEAD CONNECTED



(N.P. 1575-BA)

416820-036

REV. DESC: LOADED TO BUS, C/R 335225		
REV. LTR: -	VERSION: 00	TDR: 000000538207
FILE: \MGA\00000\682	REVISED: 11:54:06 04/30/2010	
MTL: -	BY: RAGRA	

**BALDOR**

CONN DIAG - STANDARD 3 LEAD  
SH 1 of 1