

**BALDOR • RELIANCE**

---

# Customer information packet

## XT3604T

60HP, 1780RPM, 3PH, 60HZ, 364T, A3658M, TEFC, F

Class - CLI GP A,B,C,D

Division - Division II

## Specifications

Enclosure	TEFC
Frame	364T
Frame Material	Iron
Frequency	60.00 Hz
Haz Area Class and Group	CLI GP A,B,C,D
Haz Area Division	Division II
Motor Letter Type	Three Phase
Output @ Frequency	60.000 HP @ 60 HZ
Phase	3
Synchronous Speed @ Frequency	1800 RPM @ 60 HZ
Voltage @ Frequency	230.0 V @ 60 HZ 460.0 V @ 60 HZ
Agency Approvals	CCSAUSEEV NEMA PREMIUM NEMA_PREMIUM UR
Ambient Temperature	40 °C
Auxillary Box	No Auxillary Box
Base Indicator	Rigid
Bearing Grease Type	Polyrex EM (-20F +300F)
Current @ Voltage	70.000 A @ 460.0 V 152.000 A @ 208.0 V 140.000 A @ 230.0 V
Design Code	B
Drip Cover	No Drip Cover
Duty Rating	CONT
Efficiency @ 100% Load	95.0 %
Feedback Device	NO FEEDBACK
Heater Indicator	No Heater
High Voltage Full Load Amps	70.0 a
Insulation Class	F
Inverter Code	Inverter Ready

## Part detail

Revision	H
Type	AC
Mech. spec.	
Base	
Status	PRD/A
Elec. spec.	A36WG4075
Layout	617431-412
Eff. date	07-08-2024
CD Diagram	416820-002
Poles	04
Leads	3#4,6#6
Proprietary	False
Created date	11-12-2020

<b>IP Rating</b>	NONE
<b>KVA Code</b>	G
<b>Lifting Lugs</b>	Standard Lifting Lugs
<b>Max Speed</b>	2700 rpm
<b>Motor Lead Quantity/Wire Size</b>	3 @ 4 AWG
<b>Motor Standards</b>	NEMA
<b>Motor Type</b>	A3658M
<b>Mounting Arrangement</b>	F1
<b>Number of Poles</b>	4
<b>Overall Length</b>	33.48 IN
<b>Power Factor</b>	84
<b>Product Family</b>	General Industrial
<b>Pulley End Bearing Type</b>	Ball
<b>Pulley Face Code</b>	Standard
<b>Service Factor</b>	1.15
<b>Shaft Diameter</b>	2.375 IN
<b>Shaft Ground Indicator</b>	No Shaft Grounding
<b>Shaft Rotation</b>	Reversible
<b>Shaft Slinger Indicator</b>	Shaft Slinger
<b>Speed</b>	1780 rpm
<b>Speed Code</b>	Single Speed
<b>Starting Method</b>	Direct on line
<b>Thermal Device - Bearing</b>	None
<b>Thermal Device - Winding</b>	None

**Nameplate**

**NP4152LUA**

<b>CAT #</b>	XT3604T			<b>SER</b>				<b>CC</b>	010A				
<b>SPEC</b>	A36-7841-4075			<b>RATING</b>	40C AMB-CONT								
<b>HZ</b>	<b>VOLTS</b>		<b>AMPS</b>		<b>RPM</b>	<b>HP</b>	<b>CODE</b>	<b>SF</b>	<b>DES</b>	<b>PF</b>	<b>NEMA NOM. EFF</b>		
60	230/460		140/70		1780	60	G	1.15	B	84 %	95 %	%	
										%		%	
<b>PH</b>	3	<b>CL</b>	F	<b>MAX RPM</b>	2700	<b>MAX CORR KVAR</b>	15						
<b>BRG</b>	<b>DE</b>	6313	<b>ODE</b>	6313	<b>ENCL</b>	TEFC	<b>FR</b>	364T	<b>IP</b>	54			
<b>GREASE</b>	POLYREX EM						<b>MTR WT</b>	LBS					
<b>CL I DIV 2 GRPS A,B,C,D</b>				<b>CL I ZONE 2 GRPS</b>				<b>IIA,IIB,IIC</b>			<b>TEMP T</b>	200	<b>C</b>
<b>INV READY</b>	<b>CT</b>	10-60	<b>HZ</b>	6:1	<b>VT</b>	0-60	<b>HZ</b>	1000:1	<b>CHP</b>	60-90	<b>HZ</b>	1:1.5	
<b>INV TEMP CL</b>	T3	<b>C</b>	<b>USABLE AT</b>	50HZ 50HP 190/380V 138/69A						1.0SF			

## Parts list

Part number	Description	Quantity
SA387720	SA A36-7841-4075	1.000 ea
RA378061	RA A36-7841-4075	1.000 ea
421948032	LABEL, MYLAR	1.000 ea
000692000VD	LABEL WARNING	1.000 ea
LB1449	DIV-2/NEC WARNING LABEL	1.000 ea
NP4152LUA	SS CP XT CLI DIV2 UR CSA-C US-EEV NEMA P	1.000 ea
085922073B	BRKT 360 085922072WCC KB	1.000 ea
415072001B	CLAMP	1.000 ea
078559001A	+FANCV - 360	1.000 ea
034180012DA	KEY 1X4X1/4X1-1/2 L	1.000 ea
412118006A	DRAIN	1.000 ea
702676001C	FAN 360	1.000 ea
004824015A	GREASE POLYREX EM	0.540 lb
032018012DK	HHCS 1/2-13X1-1/2 PLTD. 032018012DR	4.000 ea
032018008AK	HHCS 1/4-20X1 PLATED	4.000 ea
032018024CK	HHCS 3/8-16X3 PLTD.	3.000 ea
415096002A	CPLG 1/8 HEX TYPE	1.000 ea
415045002E	SLGR	1.000 ea
410700004F	WSHR	1.000 ea
035000001G	GREASE RELIEF FITTING, ALEMITE 317400	1.000 ea
034530052AB	P/NIP 1/8X6-1/2 Zinc	1.000 ea
034600001AA	BUSH 1/4TO1/8 BLACK	1.000 ea
034600001AA	BUSH 1/4TO1/8 BLACK	1.000 ea
085922073B	BRKT 360 085922072WCC KB	1.000 ea
032018012DK	HHCS 1/2-13X1-1/2 PLTD. 032018012DR	4.000 ea
032018024CK	HHCS 3/8-16X3 PLTD.	3.000 ea
415045002E	SLGR	1.000 ea
412118006A	DRAIN	1.000 ea
034530020AB	P/NIP 1/8X2-1/2 PLTED	1.000 ea
415096002A	CPLG 1/8 HEX TYPE	1.000 ea
035000001G	GREASE RELIEF FITTING, ALEMITE 317400	1.000 ea

077176000L	C/BOX, PAINTED 440	1.000 ea
077176001A	CBOXC, PAINTED 360-400	1.000 ea
043292000AJ	GASK 320-400	1.000 ea
402731001A	GASK 360-440	1.000 ea
418150003A	GREASE FITTING CAP	1.000 ea
032018005AK	HHCS 1/4-20X5/8 PLATED	4.000 ea
032018008CK	HHCS 3/8-16X1L PLATED	4.000 ea
035000001A	ALFTG 1/8" 1610-BL	1.000 ea
415000115H	T/LUG #2AWG-4/0AWG	1.000 ea
406099000A	PLUG - FAN COVER 320-440	1.000 ea
032018005DL	1/2-13 X 5/8 SILICON BRONZE HHCS	1.000 ea
035000001A	ALFTG 1/8" 1610-BL	1.000 ea
418150003A	GREASE FITTING CAP	1.000 ea
MG1025L14	WILKOFAS, 776.14, GRUNDFOS BLACK	0.250 ga
033775004EA	DRSCR #6-1/4 304 S.S.	4.000 ea
034180034HA	KEY 5/8X5/8X4-1/4 L	1.000 ea
14PA1000	PACKAGING 314 GROUP COMBINED PRINT	1.000 ea
HW1000A32	5/16 FL WASHER WIDE, ID=.344, OD=1.125	3.000 ea
032509020C	CARRIAGE BOLT - 360	3.000 ea

## AC induction motor performance data

Record #72794 - Typical performance - not guaranteed values

Winding	A36WG4075
Type	A3658M
Enclosure	TEFC

## Nameplate data

Rated Output			60
Volts			230/460
Full Load Amps			140/70
R.P.M.			1780
Hz	60	Phase	3
KVA Code			G
S.F.			1.15
NEMA Nom. Eff.	95	Power Factor	84
Duty			CONT
S.F. Amps			

## 460 V, 60 Hz:

## High Voltage Connection

Full Load Torque	176.4 LB-FT
Start Configuration	direct on line
Breakdown Torque	422 LB-FT
Pull-up Torque	276 LB-FT
Locked-rotor Torque	352 LB-FT
Starting Current	462 A
No-load Current	24.8
Line-line Res. @ 25°C	0.10816 Ω
Temp. Rise @ Rated Load	56°C
Temp. Rise @ S.F. Load	70°C
Locked-rotor Power Factor	32.3
Rotor inertia	0

## Load Characteristics 460 V, 60 Hz, 60 HP

% of Rated Load	NL	25	50	75	100	125	150	SF
Power Factor	4	51	73	81	84	86	85	85
Efficiency	0	92.6	95.1	95.4	95.2	94.6	93.8	94.8
Speed	1798.9	1796.4	1792.4	1788	1783.7	1778.3	1772.3	1780
Line amperes	24.8	29.7	40.7	54.4	69.7	86.6	105	79.8

# REVIEW

WINDING # A36WG4075

60 HP 3 PH 60 HZ 1780 RPM 460 V A3658M

TORQUES (LB-FT): P0=422.00 PU=276.00 LR=352.00 LRA=462.00

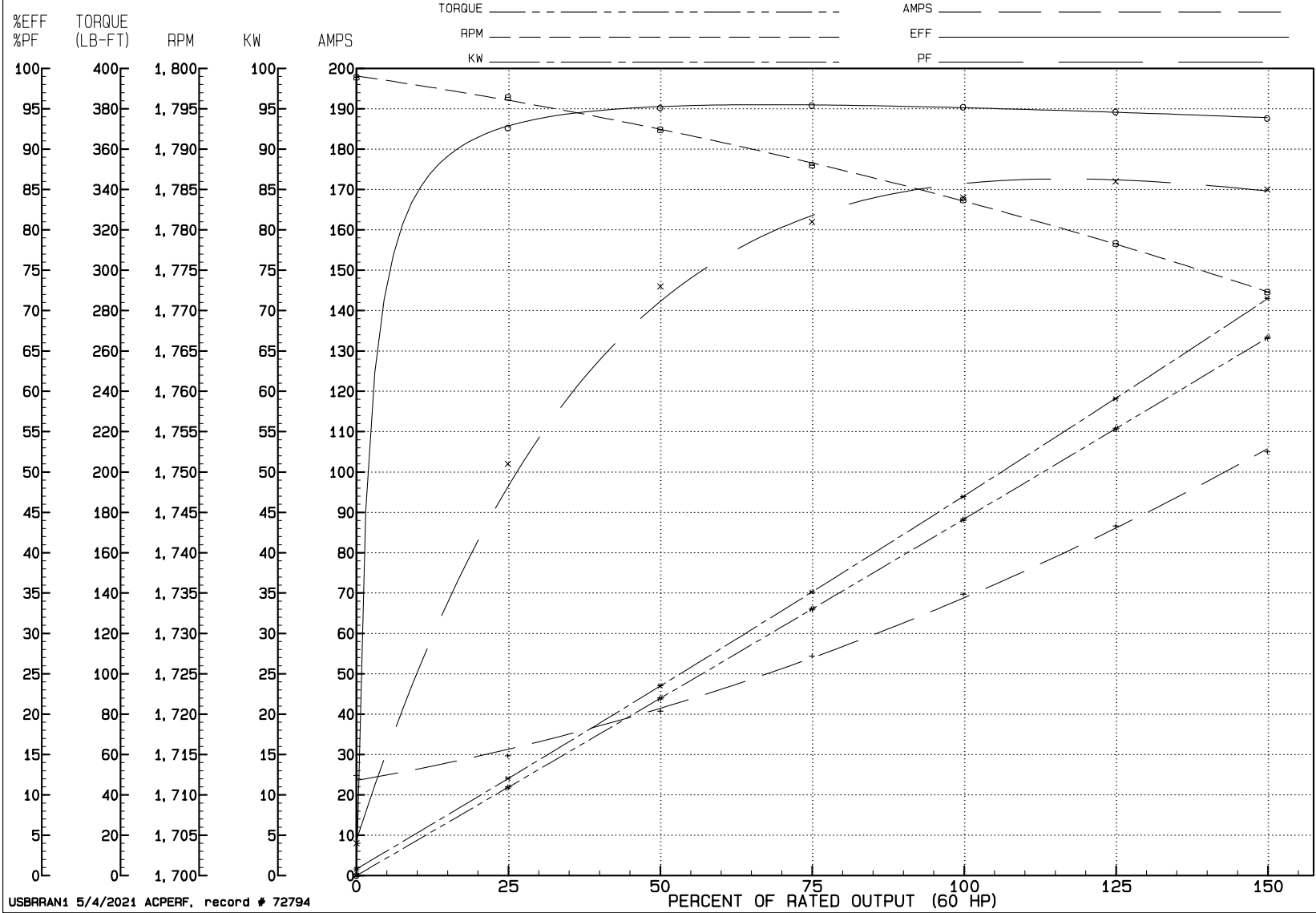

USBRRAN1 5/4/2021 ACPERF, record # 72794



617431-412

ENCLOSURE: TOTALLY ENCLOSED

MOUNTING: FOOT, F-1 SIDE

**DUTY MASTER ALTERNATING CURRENT MOTORS**

SQUIRREL-CAGE INDUCTION

E365T/E364T FRAME MOUNTING

COOLING: FAN COOLED

STEEL CONDUIT BOX

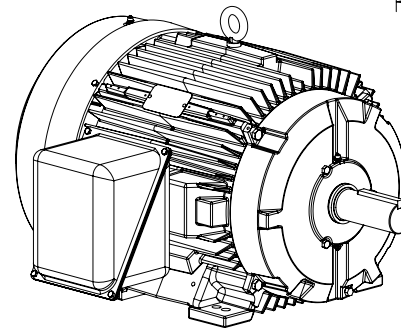
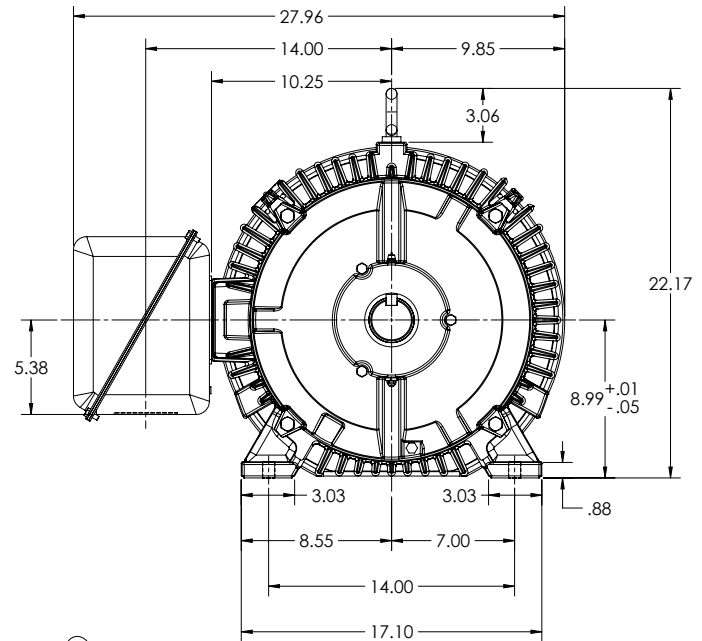
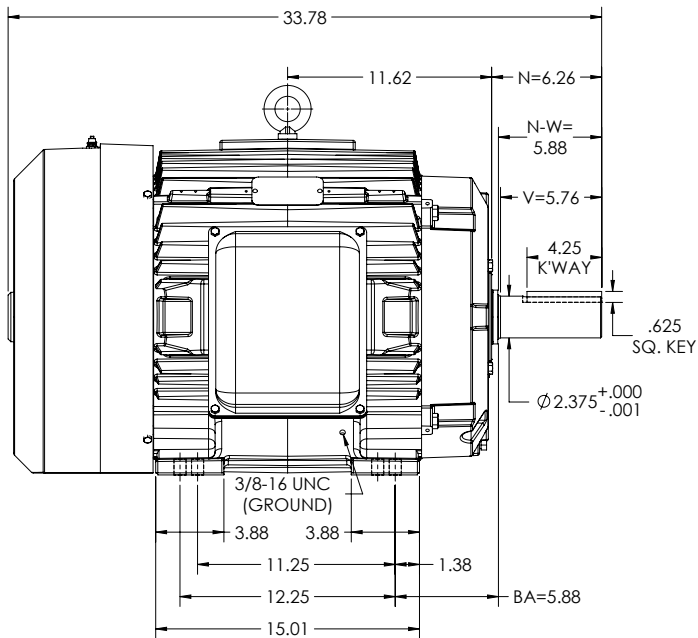

DIMENSIONS ARE IN INCHES.  
WEIGHT (LBS.) 800. MOTOR WEIGHT MAY VARY 15% DEPENDING ON RATING.  
CUSTOMER IS RESPONSIBLE FOR DETERMINING THAT MOTOR PERFORMANCE IS SUITABLE IN THE APPLICATION.

SHEET NUMBER  
1 OF 2

Z1F-137219

IF MOUNTING CLEARANCE DETAILS ARE REQUIRED, CONSULT FACTORY.  
MAX PERMISSIBLE SHAFT RUNOUT WHEN MEASURED AT END OF STANDARD SHAFT EXTENSION IS .003" T.I.R.

REV. DESC: UPDATE DS QUALITY			
REV: F	VERSION: 06	REVISED: 01-30-89 01-02-2024	TDR: 000001222947
MODEL NO. 617431-412			
BY: USJEDIL			

**BALDOR**

E365364T TEFC FOOT F1 STEEL CONDUIT BOX

617431-412

617431-412

ENCLOSURE: TOTALLY ENCLOSED

MOUNTING: FOOT, F-1 SIDE

**DUTY MASTER ALTERNATING CURRENT MOTORS**

SQUIRREL-CAGE INDUCTION

E365T/E364T FRAME MOUNTING

COOLING: FAN COOLED

STEEL CONDUIT BOX

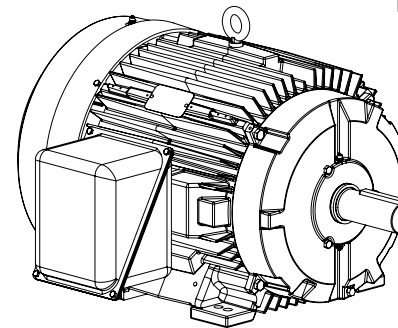
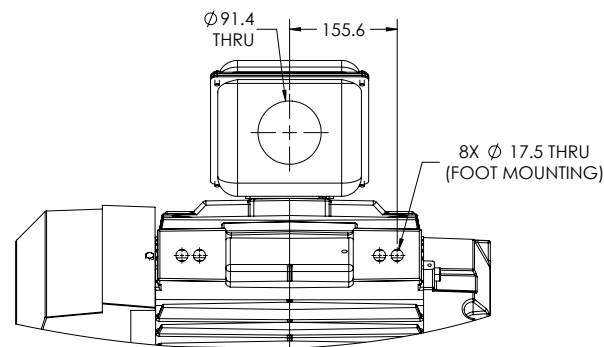
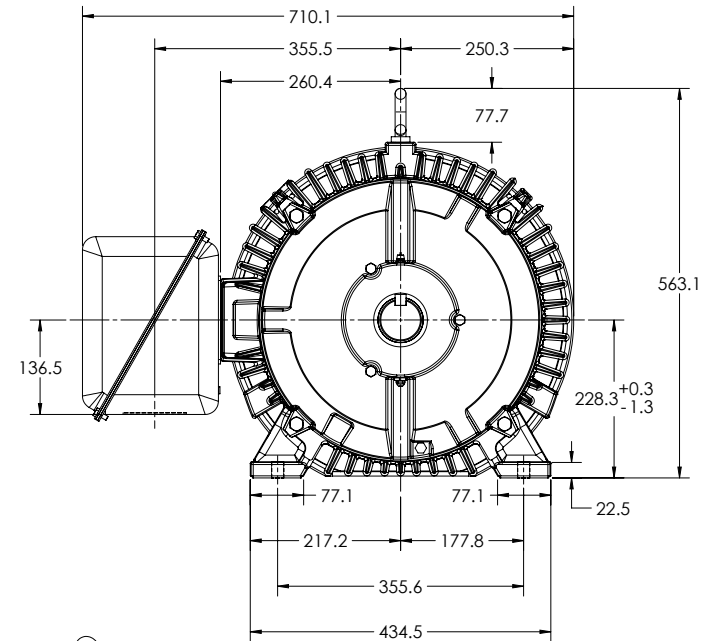
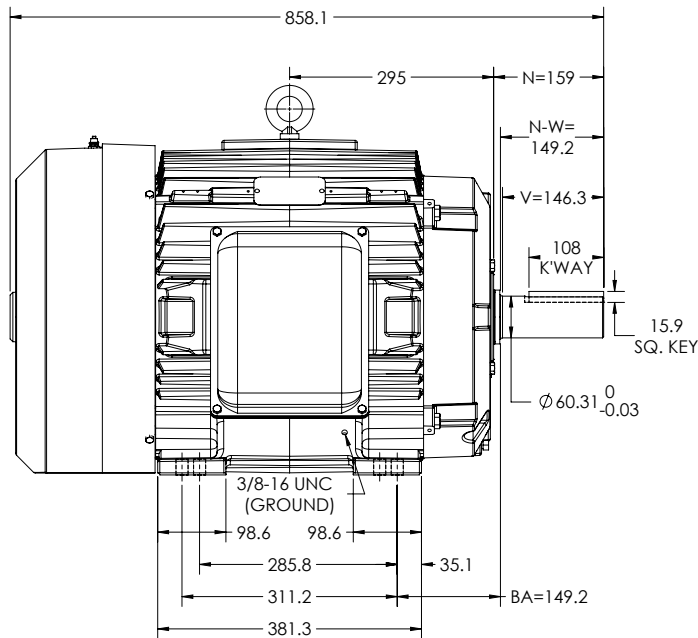

DIMENSIONS ARE IN MILLIMETERS.  
WEIGHT (KG) 362. MOTOR WEIGHT MAY VARY 15% DEPENDING ON RATING.  
CUSTOMER IS RESPONSIBLE FOR DETERMINING THAT MOTOR PERFORMANCE IS SUITABLE IN THE APPLICATION.

SHEET NUMBER  
**2 OF 2**

IF MOUNTING CLEARANCE DETAILS ARE REQUIRED, CONSULT FACTORY.  
MAX PERMISSIBLE SHAFT RUNOUT WHEN MEASURED AT END OF STANDARD SHAFT EXTENSION IS .08 T.I.R.

REV. DESC: UPDATE DS QUALITY			
REV: F	VERSION: 06	REVISED: 01-00-49 01/02/2024	TDR: 000001222947
MODEL NO. 617431-412			
BY: USJEDIL			

**BALDOR**

E365364T TEFC FOOT F1 STEEL CONDUIT BOX

617431-412

416820-002

A-C MOTOR  
 CONNECTION DIAGRAM  
 STANDARD 9 LEAD DELTA-CONNECTED

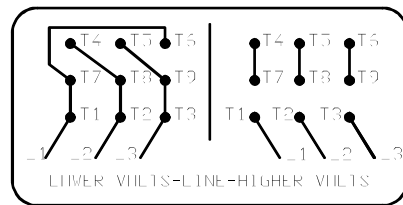
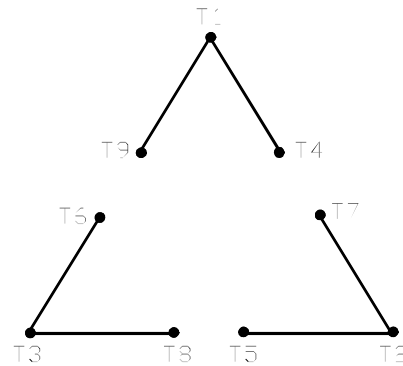

(N.P. 1575-B)

416820-002

REV. DESC: FONT CHANGE FOR PDF SEARCHABLE		
REV. LTR: A	VERSION: 01	TDR: 000001009382
FILE: \MGA\00000\661	REVISED: 02:46:19 02/13/2020	BY: MGHMTT
MTL: -	© □	

**BALDOR - RELIANCE®**

CONN DIAG - STANDARD 9 LEAD, DELTA-CONNECTED

SH 1 of 1