



Customer information packet

XT3756T

75HP, 1185RPM, 3PH, 60HZ, 405T, A40064M, TEFC

Class - CLI GP A,B,C,D

Division - Division II

Specifications

Enclosure	TEFC
Frame	405T
Frame Material	Iron
Frequency	60.00 Hz
Haz Area Class and Group	CLI GP A,B,C,D
Haz Area Division	Division II
Motor Letter Type	Three Phase
Output @ Frequency	75.000 HP @ 60 HZ
Phase	3
Synchronous Speed @ Frequency	1200 RPM @ 60 HZ
Voltage @ Frequency	230.0 V @ 60 HZ 460.0 V @ 60 HZ
Agency Approvals	CCSAUSEEV NEMA PREMIUM NEMA_PREMIUM UR
Ambient Temperature	40 °C
Auxillary Box	No Auxillary Box
Base Indicator	Rigid
Bearing Grease Type	Polyrex EM (-20F +300F)
Constant Torque Speed Range	10-60
Current @ Voltage	87.000 A @ 460.0 V 174.000 A @ 230.0 V
Design Code	B
Drip Cover	No Drip Cover
Duty Rating	CONT
Efficiency @ 100% Load	94.5 %
Feedback Device	NO FEEDBACK
Haz Area Temp Code	T3
Heater Indicator	No Heater
High Voltage Full Load Amps	87.0 a
Insulation Class	F

Part detail

Revision	E
Type	AC
Mech. spec.	
Base	
Status	PRD/A
Elec. spec.	A40WG0770
Layout	617429-001
Eff. date	07-08-2024
CD Diagram	416820-002
Poles	06
Leads	3#2,6#4
Proprietary	False
Created date	08-12-2020

Inverter Code	Inverter Ready
IP Rating	NONE
KVA Code	G
Max Speed	2700 rpm
Motor Lead Quantity/Wire Size	3 @ 2 AWG
Motor Standards	NEMA
Motor Type	A40064M
Mounting Arrangement	F1
Number of Poles	6
Overall Length	38.19 IN
Power Factor	85
Product Family	General Industrial
Pulley End Bearing Type	Ball
Pulley Face Code	Standard
Service Factor	1.15
Shaft Diameter	2.875 IN
Shaft Ground Indicator	No Shaft Grounding
Shaft Rotation	Reversible
Shaft Slinger Indicator	Shaft Slinger
Speed	1185 rpm
Speed Code	Single Speed
Starting Method	Direct on line
Thermal Device - Bearing	None
Thermal Device - Winding	None

Nameplate

NP4152LUA

CAT #	XT3756T			SER				CC	010A			
SPEC	A40-7213-0770			RATING	40C AMB-CONT							
HZ	VOLTS		AMPS		RPM	HP	CODE	SF	DES	PF	NEMA NOM. EFF	
60	230/460		174/87		1185	75	G	1.15	B	85 %	94.5 %	%
										%		%
PH	3	CL	F	MAX RPM	2700	MAX CORR KVAR	15					
BRG	DE	6316	ODE	6316	ENCL	TEFC	FR	405T	IP	54		
GREASE	POLYREX EM						MTR WT			LBS		
CL I DIV 2 GRPS A,B,C,D				CL I ZONE 2 GRPS				IIA,IIB,IIC		TEMP T	200	C
INV READY	CT	10-60	HZ	6:1	VT	0-60	HZ	1000:1	CHP	60-90	HZ	1:1.5
INV TEMP CL	T3	C	USABLE AT	50HZ 60HP 190/380V 169/84.5A						1.0SF		

Parts list

Part number	Description	Quantity
SA385052	SA A40-7213-0770	1.000 ea
RA375292	RA A40-7213-0770	1.000 ea
421948032	LABEL, MYLAR	1.000 ea
000692000VD	LABEL WARNING	1.000 ea
LB1449	DIV-2/NEC WARNING LABEL	1.000 ea
NP4152LUA	SS CP XT CLI DIV2 UR CSA-C US-EEV NEMA P	1.000 ea
412118006A	DRAIN	2.000 ea
034690005AB	PPLG 3/4 PLATED	1.000 ea
089412501A	BRKT FTMT G400 FIN MACH 6316 89412500WCA	1.000 ea
415072001B	CLAMP	1.000 ea
083198127A	G400 MOLDED FAN COVER	1.000 ea
034180012DA	KEY 1X4X1/4X1-1/2 L	1.000 ea
078550001H	FAN KB 120/60 360	1.000 ea
004824015A	GREASE POLYREX EM	0.880 lb
032018020EK	HHCS 5/8-11X2-1/2 PLTD.	4.000 ea
032018008CK	HHCS 3/8-16X1L PLATED	4.000 ea
032018026CK	HHCS 3/8-16X3-1/4 PLTD.	3.000 ea
034631002AB	BUSH 1/4 TO 1/8 PLTD.	1.000 ea
415096002A	CPLG 1/8 HEX TYPE	1.000 ea
415045002B	SLGR	1.000 ea
410700000DA	WAVY SPRING WASHER	1.000 ea
035000001G	GREASE RELIEF FITTING, ALEMITE 317400	1.000 ea
034001014AB	FLAT WASHER 3/8"PLATED	4.000 ea
034530056AB	1/8 X 7 PP NIPPLE	1.000 ea
034530056BB	P/NIP 1/4X7 SCHED 40	1.000 ea
089412501A	BRKT FTMT G400 FIN MACH 6316 89412500WCA	1.000 ea
032018020EK	HHCS 5/8-11X2-1/2 PLTD.	4.000 ea
032018026CK	HHCS 3/8-16X3-1/4 PLTD.	3.000 ea
415045002B	SLGR	1.000 ea
034530040AB	P/NIP 1/8X5 GALV.	1.000 ea
034530040BB	P/NIP 1/4X5	1.000 ea

034631002AB	BUSH 1/4 TO 1/8 PLTD.	1.000 ea
415096002A	CPLG 1/8 HEX TYPE	1.000 ea
035000001G	GREASE RELIEF FITTING, ALEMITE 317400	1.000 ea
077176000L	C/BOX, PAINTED 440	1.000 ea
077176001A	CBOXC, PAINTED 360-400	1.000 ea
043292000AJ	GASK 320-400	1.000 ea
402731001A	GASK 360-440	1.000 ea
418150003A	GREASE FITTING CAP	1.000 ea
032018005AK	HHCS 1/4-20X5/8 PLATED	4.000 ea
032018008CK	HHCS 3/8-16X1L PLATED	4.000 ea
032018005DL	1/2-13 X 5/8 SILICON BRONZE HHCS	1.000 ea
035000001A	ALFTG 1/8" 1610-BL	1.000 ea
415000115H	T/LUG #2AWG-4/OAWG	1.000 ea
406099000A	PLUG - FAN COVER 320-440	1.000 ea
035000001A	ALFTG 1/8" 1610-BL	1.000 ea
418150003A	GREASE FITTING CAP	1.000 ea
MG1025L14	WILKOFAS, 776.14, GRUNDFOS BLACK	0.380 ga
033775004EA	DRSCR #6-1/4 304 S.S.	4.000 ea
034180044JA	KEY 3/4X3/4X5-1/2 L	1.000 ea
604797045	STD. 400 FRAME SKID	1.000 ea
032510024D	CARRIAGE BOLT - 444	2.000 ea
034001014AB	FLAT WASHER 3/8"PLATED	2.000 ea
034001016AB	WSHR .562ID 1.375OD .109	2.000 ea
033300014AC	HEX NUT, SHIPPING - 400	2.000 ea
604799003C	PLASTIC BAG 42X32X46	1.000 ea

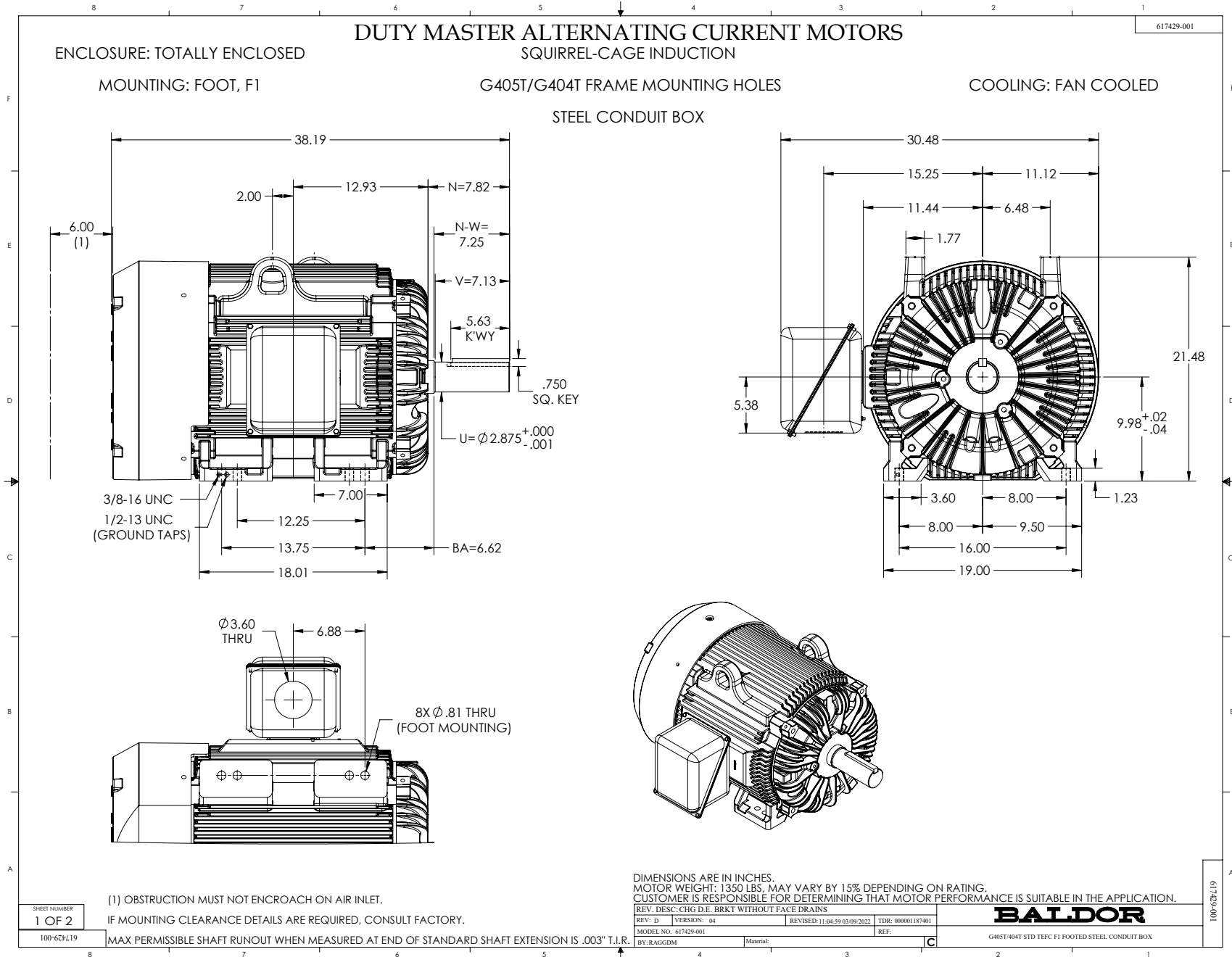

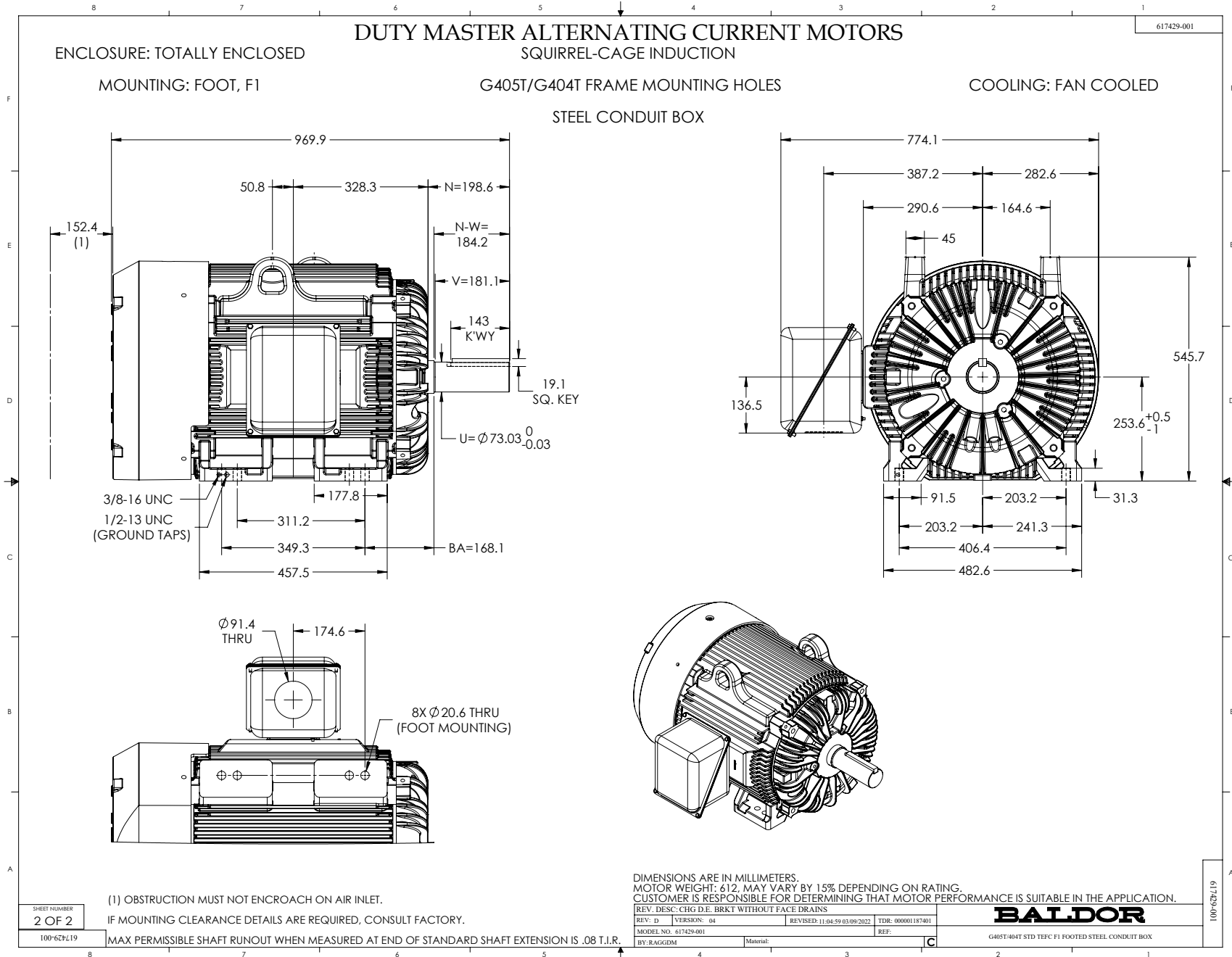

416820-002

A-C MOTOR
 CONNECTION DIAGRAM
 STANDARD 9 LEAD DELTA-CONNECTED

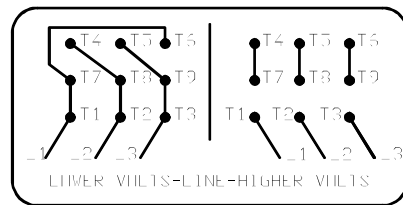
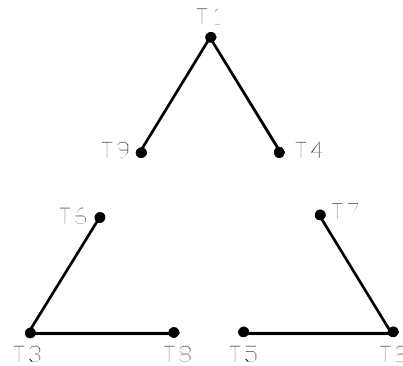

(N.P. 1575-B)

416820-002

REV. DESC: FONT CHANGE FOR PDF SEARCHABLE		
REV. LTR: A	VERSION: 01	TDR: 000001009382
FILE: \MGA\00000\661	REVISED: 02:46:19 02/13/2020	BY: MGHMTT
MTL: -	© □	

BALDOR - RELIANCE®

CONN DIAG - STANDARD 9 LEAD, DELTA-CONNECTED

SH 1 of 1