



Customer information packet

ZDVSM4115T

50HP, 1775RPM, 3PH, 60HZ, 326T, 1272M, TEFC, F1

Class - None

Division - Not Applicable

Specifications

Enclosure	TEFC
Frame	326T
Frame Material	Iron
Frequency	60.00 Hz
Haz Area Class and Group	None
Haz Area Division	Not Applicable
Motor Letter Type	Three Phase
Output @ Frequency	50.000 HP @ 60 HZ
Phase	3
Synchronous Speed @ Frequency	1800 RPM @ 60 HZ
Voltage @ Frequency	230.0 V @ 60 HZ 460.0 V @ 60 HZ
Agency Approvals	UR CSA
Ambient Temperature	40 °C
Auxillary Box	No Auxillary Box
Auxillary Box Lead Termination	None
Base Indicator	Rigid
Bearing Grease Type	Polyrex EM (-20F +300F)
Blower	None
Current @ Voltage	116.000 A @ 230.0 V 58.000 A @ 460.0 V
Design Code	A
Drip Cover	No Drip Cover
Duty Rating	CONT
Efficiency @ 100% Load	94.5 %
Electrically Isolated Bearing	Not Electrically Isolated
Feedback Device	ENCODER
Front Shaft Indicator	None
Heater Indicator	No Heater
High Voltage Full Load Amps	58.0 a
Insulation Class	F

Part detail

Revision	D
Type	AC
Mech. spec.	12G535
Base	
Status	PRD/A
Elec. spec.	12WGZ279
Layout	12LYG535
Eff. date	11-21-2024
CD Diagram	CD0180
Poles	04
Leads	9#8
Proprietary	False
Created date	02-03-2021

Inverter Code	Inverter Duty
KVA Code	H
Lifting Lugs	Standard Lifting Lugs
Locked Bearing Indicator	Locked Bearing
Max Speed	2700 rpm
Motor Lead Quantity/Wire Size	9 @ 6 AWG
Motor Lead Termination	Flying Leads
Motor Standards	NEMA
Motor Type	1272M
Mounting Arrangement	F1
Number of Poles	4
Overall Length	33.14 IN
Power Factor	85
Product Family	General Purpose
Pulley End Bearing Type	Ball
Pulley Face Code	Standard
Pulley Shaft Indicator	Standard
Rodent Screen	None
RoHS Status	ROHS NON-COMPLIANT
Service Factor	1.00
Shaft Diameter	2.125 IN
Shaft Ground Indicator	No Shaft Grounding
Shaft Rotation	Reversible
Shaft Slinger Indicator	Shaft Slinger
Speed	1775 rpm
Speed Code	Single Speed
Starting Method	Direct on line
Thermal Device - Bearing	None
Thermal Device - Winding	Normally Closed Thermostat
Vibration Sensor Indicator	No Vibration Sensor
Winding Thermal 1	None
Winding Thermal 2	None

Nameplate

NP3304L			
CAT NO	ZDVSM4115T		
SPEC.	12G535Z279Z1		
FRAME	326T	HP	50 TE
VOLTS	230/460		
MAG CUR	40/20	FLA	116/58
RPM	1775	RPM MAX	2700
HZ	60	PH	3 CLASS F
SER.F.	1.00	SL HZ	0.8
NEMA-NOM-EFF	94.5	WK2	9.59
RATING	40C AMB-CONT		
DE BRG	6312	ODE BRG	6311
CC	010A	SER.NO	
	1.5:1 CHP PWM		

Parts list

Part number	Description	Quantity
SA390458	SA 12G535Z279Z1	1.000 ea
RA380907	RA 12G535Z279Z1	1.000 ea
09FN3001C03	EXTERNAL FAN, PLASTIC (COMES W/SCREW FRO	1.000 ea
10CB3001	CONDUIT BOX CAST W/2.500 LEAD HOLE	1.000 ea
09GS1000	GASKET-CONDUIT BOX, 1/16 THICK LEXIDE	1.000 ea
10XN3118K12	5/16-18 X .75 GRADE 5, ZINC PLATED	4.000 ea
HW1001A31	LOCKWASHER 5/16, ZINC PLT.591 OD, .319 I	4.000 ea
WD1000B25	GND LUG, BURNDY L125HP OR T&B L125HP-BB	1.000 ea
19XW3118G08	.31-18X.50,HEX WSHR HD,TAPTITE 2,GREEN	1.000 ea
HW1001A31	LOCKWASHER 5/16, ZINC PLT.591 OD, .319 I	4.000 ea
HA4017A01	1/8 X 4 GREASE EXT (F/S)	1.000 ea
12EP1107A05	FR ENDPLATE, MACH	1.000 ea
HA3400A13	STUD, 1/2-13 X 7" WELKER	4.000 ea
HW1001A50	LOCKWASHER 1/2, ZINC PLT,.879 OD, .509 I	4.000 ea
HW1001A50	LOCKWASHER 1/2, ZINC PLT,.879 OD, .509 I	4.000 ea
10XN3118K40	5/16-18 X 2.25" HEX HD, GRADE 5	2.000 ea
HW1001A31	LOCKWASHER 5/16, ZINC PLT.591 OD, .319 I	2.000 ea
HW5100A13	W4627-047 WVY WSHR	1.000 ea
12EP1106A01	PU ENDPLATE, MACH	1.000 ea
10XN5013K28	1/2-13 X 1.75 HEX HEAD MACH SCREW,GRAD	4.000 ea
HW1001A50	LOCKWASHER 1/2, ZINC PLT,.879 OD, .509 I	4.000 ea
HW4600B41	V-RING SLINGER 2.125 X 2.880 X 0.280	1.000 ea
10XN3118K40	5/16-18 X 2.50" HEX HD, GRADE 5	4.000 ea
12FH1002A27	FAN COVER, MACH	1.000 ea
XY5013A12	NUT,1/2-13,HEX,STEEL,ZINCPLATED	4.000 ea
10XN2520K12	1/4-20 X.75 GRD 5	1.000 ea
HW1001A25	LOCKWASHER 1/4, ZINC PLT .493 OD, .255 I	1.000 ea
HA6881	BEI HS35 THRU SHAFT ENCODER PROTECTIVE C	1.000 ea
10XN2520K12	1/4-20 X.75 GRD 5	2.000 ea
HW1001A25	LOCKWASHER 1/4, ZINC PLT .493 OD, .255 I	2.000 ea
10CB3500SP	CONDUIT BOX LID, CAST	1.000 ea

10GS1000SP	GASKET, CONDUIT BOX LID	1.000 ea
51XW2520A12	.25-20 X .75, TAPTITE II, HEX WSHR SLTD	4.000 ea
HW2501H33	KEY, 1/2 SQ X 3.875	1.000 ea
HA4051A00	PLASTIC CAP FOR GREASE FITTING	1.000 ea
HW4500A21	1618BALEMITE FITTING 825 UNIVERSAL	1.000 ea
HW4500A17	317400 ALEMITE GREASE RELIEF	1.000 ea
HA4054	SHORT T-DRAIN FITTING, .125" N.P.T.	1.000 ea
MJ1000A02	GREASE, POLYREX EM EXXON	0.200 lb
HA4051A00	PLASTIC CAP FOR GREASE FITTING	1.000 ea
HW4500A03	GREASE FITTING, .125 NPT 1610(ALEMITE) 8	1.000 ea
HW4500A17	317400 ALEMITE GREASE RELIEF	1.000 ea
HA4054	SHORT T-DRAIN FITTING, .125" N.P.T.	1.000 ea
HW2500A25	WOODRUFF KEY USA #1008 #BLOW CARBON STEE	1.000 ea
OE5001A80SP	ENCDR KIT TENV W/OEHS35A10 W/BLIND SHAFT	1.000 ea
MG1025N19	WILKOFAS, 778.50, RELIANCE BLUE-GREEN 8	0.080 ga
85XU0407S04	4X1/4 U DRIVE PIN STAINLESS	2.000 ea
LB1624	COMBINED WARNING LABEL, ISO/ANSI PICTOGR	1.000 ea
LC0181	CONNECTION LABEL	1.000 ea
NP3304L	ALUM VEC UL CSA CC (W/OUT DESIGN FIELD)	1.000 ea
10PA1010	PACKAGING GROUP, PRINT PK1151A06	1.000 ea
MN416A01	TAG-INSTAL-MAINT no wire (2500bx)4/22	1.000 ea
LD7026F09	LEAD SET, 8 AWG, 9 LEAD, 26" LONG LEADS	1.000 ea
PE-0000013	ZRTG PE ASSEMBLY	1.000 ea
FE-0000022	ZRTG FE ASSEMBLY	1.000 ea

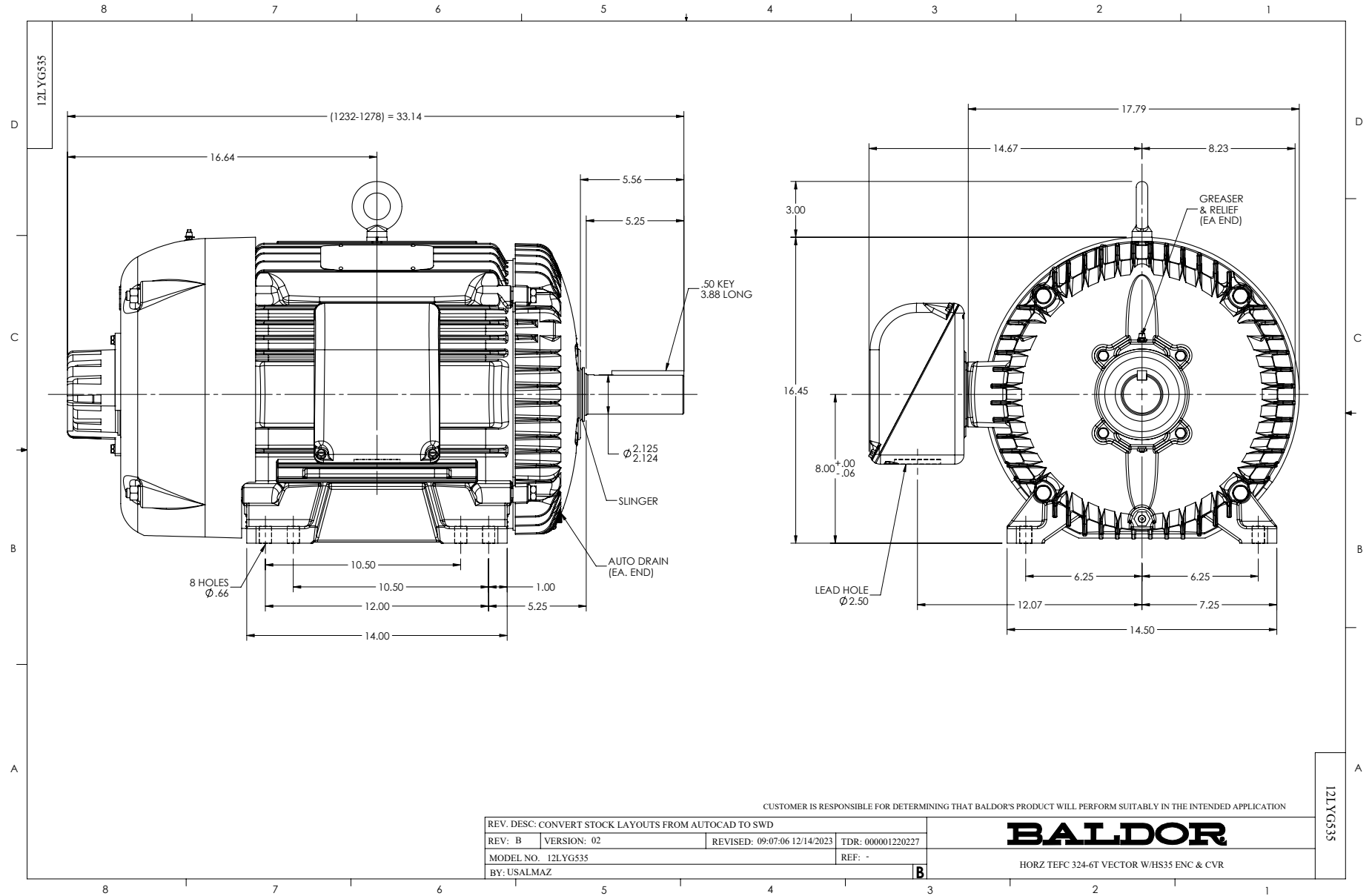

CD0180

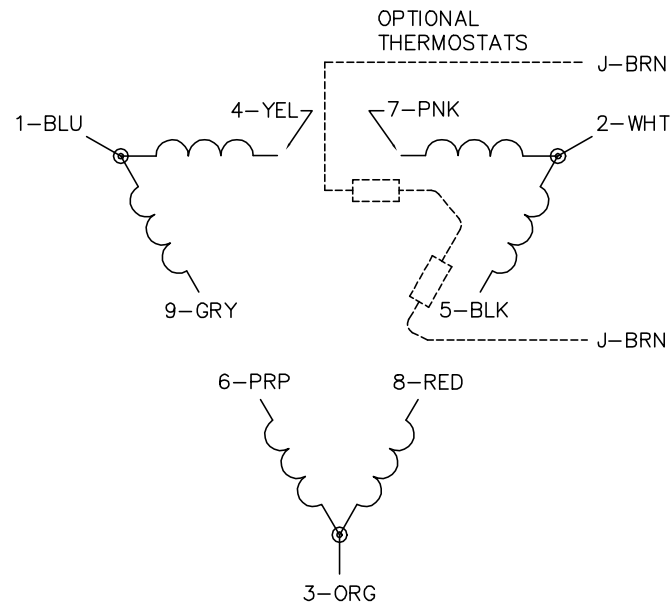

LOW VOLTAGE
(2D)



HIGH VOLTAGE
(1D)



NOTES:

1. INTERCHANGE ANY TWO LINE LEADS TO REVERSE ROTATION.
2. OPTIONAL THERMOSTATS ARE PROVIDED WHEN SPECIFIED.
3. ACTUAL NUMBER OF INTERNAL PARALLEL CIRCUITS MAY BE A MULTIPLE OF THOSE SHOWN ABOVE.
4. LEAD COLORS ARE OPTIONAL. LEADS MUST ALWAYS BE NUMBERED AS SHOWN.

CD0180

REV. DESC: ADD CLASS CONN00000007		
REV. LTR: D	VERSION: 01	TDR: 000001099922
FILE: \AAA\00005\148	REVISED: 10: 25: 29 02/19/2019	BY: ENBRIRO
MTL: -	© □	

BALDOR - RELIANCE®

3PH, DV, 9 LEADS, DELTA CONNECTION

SH 1 of 1